



# Air Conditioner Product Manual

## Vertical Wall-Mount Air Conditioners with Front Control Box Panel

## Installation & Operation Manual

10 & 11 EER Vertical Wall-Mount Air Conditioners

### **MODELS:**

MAH1018A-MAH1060A & MGH1072A  
(Single Stage)

MAH2024A-MAH2060A & MGH2072A  
(2-Stage)



### **IMPORTANT**

This manual may include information for options and features which may not be included on the unit being installed. Refer to the unit data label or Model Identification to determine which features and options this unit is equipped with.

**INSTALLER:** Affix the instructions on the inside of the building adjacent to the thermostat.  
**END USER:** Retain this manual for future reference.

*Manufactured By:*

**Marvair, An AirX Climate Solutions Brand**

P.O. Box 400 • Cordele, Georgia 31010 • 156 Seedling Drive • Cordele, Georgia 31015  
(229) 273-3636 • Fax (229) 273-5154

E-mail: [marvairsales@airxcs.com](mailto:marvairsales@airxcs.com) • Internet: [www.Marvair.com](http://www.Marvair.com)

The most current version of this manual can be found at [www.Marvair.com](http://www.Marvair.com).

## How To Use This Manual

This manual is intended to be a guide to the Marvair Wall Mount family of vertical air conditioners. It contains installation, troubleshooting, maintenance, warranty, and application information. The information contained in this manual is to be used by the installer as a guide only. This manual does not supersede or circumvent any applicable national or local codes. If you are installing the Marvair unit, first read Chapter 1 and scan the entire manual before beginning the installation as described in Chapter 2. Chapter 1 contains general, descriptive information and provides an overview which can speed up the installation process and simplify troubleshooting.

If a malfunction occurs, follow this troubleshooting sequence:

1. Make sure you understand how the Marvair unit works (Chapters 1 & 3).
2. Identify and correct installation errors (Chapter 2).
3. Refer to the troubleshooting information in Chapter 4.

If you are still unable to correct the problem, contact the Factory at 1-800-841-7854 for additional assistance.

**Please read the following “Important Safety Precautions” before beginning any work.**

## Important Safety Precautions

1. This unit uses an A2L, or mildly flammable, refrigerant. Extra precautions should be taken when handling or servicing the unit so as not to puncture the refrigerant tubing.



**Refrigerant  
Safety Group  
A2L**

**WARNING - Risk Of Fire. Flammable Refrigerant Used.  
To Be Repaired Only By Trained Service Personnel. Do  
Not Puncture Refrigerant Tubing.**

**WARNING - Risk Of Fire. Dispose Of Properly In  
Accordance With Federal Or Local Regulations.  
Flammable Refrigerant Used.**

2. LEAK DETECTION SYSTEM Installed. Unit must be powered on except for service.
3. FULLY EVACUATE the system and verify that there is no refrigerant in the working area before brazing.
4. USE CARE when LIFTING or TRANSPORTING equipment.
5. TRANSPORT the UNIT UPRIGHT. Laying it down on its side may cause oil to leave the compressor and breakage or damage to other components.
6. TURN ELECTRICAL POWER OFF AT THE breaker or fuse box BEFORE installing or working on the equipment. LINE VOLTAGES ARE HAZARDOUS or LETHAL.
7. OBSERVE and COMPLY with ALL applicable PLUMBING, ELECTRICAL, and BUILDING CODES and ordinances.
8. DO NOT USE MEANS TO ACCELERATE THE DEFROSTING PROCESS OR TO CLEAN, other than those recommended by the manufacturer.
9. The appliance shall be stored in a room without continuously operating ignition sources (for example: open flames, an operating gas appliance or an operating electric heater).
10. DO NOT PIERCE OR BURN.
11. BE AWARE THAT REFRIGERANTS MAY NOT CONTAIN AN ODOR.
12. SERVICE may be performed ONLY by QUALIFIED and EXPERIENCED PERSONS.
  - \* **Wear safety goggles when servicing the refrigeration circuit**
  - \* **Beware of hot surfaces on refrigerant circuit components**
  - \* **Beware of sharp edges on sheet metal components**
  - \* **Use care when recovering or adding refrigerant**
13. Use **COMMON SENSE - BE SAFETY-CONSCIOUS**

This is the safety alert symbol . When you see this symbol on the Marvair unit and in the instruction manuals be alert to the potential for personal injury. Understand the signal word DANGER, WARNING, CAUTION and IMPORTANT. These words are used to identify levels of the seriousness of the hazard.

AS PART OF THE MARVAIR CONTINUOUS IMPROVEMENT PROGRAM, SPECIFICATIONS ARE SUBJECT TO CHANGE WITHOUT NOTICE.  
© 05/2026 Marvair, An AirX Climate Solutions Brand

 **DANGER**

Failure to comply will result in death or severe personal injury and/or property damage.

 **WARNING**

Failure to comply could result in death or severe personal injury and/or property damage.

 **CAUTION**

Failure to comply could result in minor personal injury and/or property damage.

**IMPORTANT**

Used to point out helpful suggestions that will result in improved installation, reliability or operation.

 **WARNING**

- If the information in these instructions are not followed exactly, a fire may result causing property damage, personal injury or loss of life.
- Read all instructions carefully prior to beginning the installation. Do not begin installation if you do not understand any of the instructions.
- Improper installation, adjustment, alteration, service or maintenance can cause property damage, personal injury or loss of life.
- Installation and service must be performed by a qualified installer or service agency in accordance with these instructions and in compliance with all codes and requirements of authorities having jurisdiction.

**INSTALLER:** Affix the instructions on the inside of the building adjacent to the thermostat.  
**END USER:** Retain these instructions for future reference.

## Table of Contents

### Chapter 1 Marvair Wall Mount Air Conditioner Description & Specifications

1.1	General Description .....	5
1.2	Model Identification .....	5
1.3	Serial Number Date Code .....	6
1.4	Air Flow, Weights and Filter Sizes.....	6
1.5	General Operation .....	8
1.6	Optional Controls and Packages .....	9
1.7	Electrical Operation .....	11

### Chapter 2 Electronic Control Board

2.1	Introduction .....	17
2.2	Installation and Replacement .....	18
2.3	PCB Details and Information .....	18
2.4	Operation.....	22
2.5	Sequence of Operation .....	23
2.6	Mitigation Board Sequence of Operation .....	34

### Chapter 3 Installation

3.1	Equipment Inspection.....	36
3.2	Pre Checks.....	36
3.3	Installation Requirements.....	36
3.4	Installation Materials .....	38
3.5	Porting and Duct Work .....	39
3.6	Fresh Air Hood Installation .....	40
3.7	Bracket Installation .....	41
3.8	Mounting the Unit .....	41
3.9	Electrical Connections .....	42

<b>Chapter 4 Start-Up</b>	
4.1	Check-Out of Cooling Cycle ..... 46
4.2	Check-Out of Heating Cycle..... 46
<b>Chapter 5 Troubleshooting</b>	
5.1	Overview ..... 47
5.2	Failure Symptoms Guide..... 48
5.3	Compressor Troubleshooting ..... 48
5.4	Control Board Diagnosis..... 49
5.5	Control Board Diagnosis (Alternate Construction)..... 49
<b>Chapter 6 Maintenance</b>	
6.1	Scheduled Maintenance ..... 51
<b>Chapter 7 Service &amp; Charging/Recovery</b>	
7.1	Safety Precautions..... 52
7.2	Leak Detection ..... 52
7.3	Charging Procedures ..... 53
7.4	Refrigerant Recovery ..... 53
<b>Chapter 8 Decommissioning</b>	
8.1	Decommissioning..... 55
<b>Chapter 9 Start-Up Checklist</b>	
9.1	Start-Up & Commissioning Form..... 56
<b>Chapter 10 Warranty</b>	
10.1	Marvair Limited Product Warranty ..... 60
<b>Appendix A</b>	
	Electronic Control Board Modbus Map..... 61
<b>Appendix B</b>	
	Installation Instructions for Field Installed Electric Heaters ..... 64
<b>Illustrations</b>	
Figure 1a.	Typical Electrical Schematic - Model MAH..... 12
Figure 1b.	Typical Electrical Schematic - Model MAH with Economizer ..... 13
Figure 1c.	Typical Electrical Schematic - Model MAH (Alternate Construction with Economizer) ..... 14
Figure 1d.	Typical Electrical Schematic - Model MAH (Alternate Construction with Economizer) ..... 15
Figure 1e.	Typical Electrical Schematic - Model MAH (Alternate Construction with Economizer) ..... 16
Figure 2.	Enthalpy Sensor and Temperature Control Points ..... 27
Figure 3.	Dry Bulb sensor..... 28
Figure 4.	Fresh Air Hood Damper, Models 1024A-1072A ..... 40
Figure 5.	Wall Mounting Detail..... 41
Figure 6a.	Humidistat Wiring Details to a Marvair Air Conditioner with Reheat ..... 44
Figure 6b.	Thermostat Connection Diagram ..... 44
Figure 6c.	CommStat™ 4 HVAC Controller Wiring Detail..... 45
<b>Tables</b>	
Table 1	CFM @ External Static Pressure ..... 7
Table 2	Return Air Filter Sizes ..... 7
Table 3	Installed Unit Weights..... 7
Table 4	Ambient Temperature Operating Range ..... 7
Table 5	Refrigerant Charge..... 7
Table 6	Room Size Limitations ..... 8
Table 7	Altitude Correction Factor ..... 8
Table 8	Minimum Clearances ..... 37
Table 9	Voltage Limitations ..... 38
Table 10	Maximum Static Pressure ..... 40
Table 11	Refrigerant Charge..... 53

# Chapter 1 Description & Specifications

## 1.1 General Description

The Marvair MAH and MGH are a series of vertical wall-mounted air conditioning systems that provide heating, cooling, and ventilation for electronic equipment shelters, process control centers, and other applications with high internal heat gains. The series includes multiple sizes and nominal cooling capacities from 18,000 to 72,000 BTUH. Resistance heating elements are available in various wattages.

MAH models are available with cooling capacities of 18,000 to 60,000 BTUH and EER's of 11.00 to 11.50. MGH models have 72,000 BTUH (6 ton) capacity and are 10 EER. The Marvair Product Data Sheets have detailed information on the capacities and efficiencies for each model.

See Appendix A for instructions on field installation of electric heat.

Marvair air conditioners feature an exclusive electronic control board. The control board consolidates several of the electrical components and improves the air conditioner's reliability. The control board replaces the blower relay, the lockout relay, the compressor time delay and the timed low pressure bypass. In addition, the control board has LED's to indicate operating status and fault conditions to assist the service technician. A complete description of functions of the control board is in Chapter 2.

All models are designed for easy installation and service. Major components are accessible for service beneath external panels.

All units have internal disconnects (optional on 380V and 575V). Follow local codes for external disconnect requirements.

Marvair wall mount air conditioners have a 0-15% manual outside air damper as standard equipment. All models are available with an optional factory installed economizer for 100% free cooling with outside air.

Marvair wall mount air conditioners are intended for operation up to 16,400 feet above sea level. Unit performance will be affected by altitude.

All models in this manual are equipped with a leak detection system. Once the unit is installed it must be powered, at all times, except for service. During normal operation the leak detection system has no impact on the operation of the unit, however upon detection of R-454B refrigerant all operations are stopped except for the indoor blower. The unit will then re-circulate air in the room for a minimum of 5 minutes. Once the 5 minutes have expired and the concentration of the refrigerant is below 8 percent of the Lower Flammability Limit (LFL) the unit will be allowed to operate as normal. If the concentration of the refrigerant remains above 8 percent of the LFL the unit will remain in re-circulation mode. To verify actuation of mitigation simply remove the sensor from the mitigation control board and the system should stop all operation except for the indoor blower. There is no need to calibrate or service the sensor. The sensor will provide an alarm upon failure or end of life. The sensor must be replaced with an identical sensor, or a manufacturer approved alternative.

## 1.2 Serial Number Date Code

20 = 2020	01 = January	05 = May	09 = September
21 = 2021	02 = February	06 = June	10 = October
22 = 2022	03 = March	07 = July	11 = November
23 = 2023	04 = April	08 = August	12 = December

### 1.3 Model Identification

The model identification number is found on the data sticker. Rating plate located on side panel.

Example	M	A	H	1	0	3	6	A	D	0	5	0	C	+	+	+	+	1	E	A	+	C	3	1	+	+	+	+	+	+
Position	1	2	3	4	5	6	7	8	9	10	11	12	13	14	15	16	17	18	19	20	21	22	23	24	25	26	27	28	29	30

1	Unit Designation/Family	M = Marvair Wall Mount S = Stock Unit
2	Energy Efficiency Ratio (EER)	A = 11 G = 10
3	Refrigerant Type	H = R-454B
4	Compressor Type/Quantity	1 = Fixed Speed/Single 2 = 2-Stage/Single (2 - 6 Ton Models)
5	Unit Capacity/Nominal Cooling (BTUH)	018 = 18,000
6		020 = 20,000
7		024 = 24,000
8		030 = 30,000
9	System Type	A = Air Conditioner
10	Power Supply (Volts-Hz-Phase)	A = 208/230-60-1
11		C = 208/230-60-3
12		D = 460-60-3 Z = 575-60-3
10	Heat Designation @ Rated Voltage	000 = No Heat
11		022 = 2.2KW
12		036 = 3.6KW
11		080 = 8KW
12		090 = 9KW
13		100 = 10KW
12		120 = 12KW
13		150 = 15KW
13		Ventilation Configuration
14	C = Economizer	
15	D = Motorized Damper w/Pressure Relief	
16	Dehumidification	E = Motorized Damper w/Pressure Relief & Independent Motorized Damper Control
17		F = No Free Cooling, 100% Emergency Ventilation Only w/Independent Control
18		H = GreenWheel® ERV
18	Controls	N = Barometric Damper w/15% OSA
19		T = Title 24 Compliant Economizer & Controls
20		V = Economizer (VZW)
20	Operating Condition	+ = None
21		\$ = Special
22		G = Hot Gas Reheat
22		R = Electric Reheat
23		+ = None
24		\$ = Special
24	Cabinet Color	A = Power Fail Alarm w/Additional Lockouts
25		C = 24V EMS Relay Kit
26		H = Factory Installed PLC
26	Security Option	+ = None (Standard)
27		\$ = Special
28		D = Desert Duty
28	Fastener/Drain Pan Option	F = Desert Duty w/Hard Start
29		V = Hard Start w/Low Ambient & CCH & EFS
30		Z = Low Ambient w/CCH & EFS
30	Special Variation	2 = Low Ambient & EFS (STD)
31		\$ = Special
32		

**Note:** Not all options are available with all configurations. Contact your Marvair sales representative for configuration details and feature compatibility.

17	Indoor Air Quality Features	A = UV Light D = Dry Bulb Sensor E = Dry Bulb Sensor w/Dirty Filter G = Dirty Filter Sensor K = Bi-Polar Ionization V = Dry Bulb, Dirty Filter & Dust Sensor + = None \$ = Special
18	Air Flow	1 = Top Supply/Center Return (Standard) 2 = Center Supply/Top Return 3 = Bottom Supply/Middle Return (1018 only) 6 = 3T3 w/Top Supply/Center Return 7 = 3T5 w/Top Supply/Center Return 9 = 4T3 D = 3T3 Center Supply/Top Return E = 3T5 Center Supply/Top Return \$ = Special
19	Compressor Location	C = Center - All 6 ton units & 5 ton Center Supply/Top Return D = Left Hand - All 3 1/2 to 5 ton units E = Right Hand - All 1 1/2 to 3 ton units
20	Filter Option	A = 2" Pleated (MERV 8, AC/HP-C) D = MERV 11 High Filtration Package E = MERV 13 High Filtration Package W = Aluminum Washable + = None \$ = Special
21	Corrosion Protection	A = Condenser Coil Only C = Evaporator Coil Only D = Both Coils Condenser & Evaporator E = All Coils Cond/Evap/Reheat F = Coat All G = Coastal Package & Evaporator Coil K = Coastal Package + = None \$ = Special
22	Engineering Revision Level	C3   D3
23		
24	Sound Attenuation	1 = Marvair Beige (Standard) 2 = Gray (Standard) 3 = Carlsbad Canyon (Standard) 4 = White (Standard) 5 = Stainless Steel Exterior A = Stainless Steel - Unit \$ = Custom Color
25		2 = Compressor Blanket + = None
26		A = Lockable Access Plate/Tamper Proof + = None \$ = Special
27	Fastener/Drain Pan Option	A = Stainless Steel Fasteners C = Stainless Steel Drain Pan D = Stainless Steel Fasteners & Drain Pan + = None \$ = Special
28		+ = None \$ = Special
29		+ = None \$ = Special
30	Special Variation	+ = None \$ = Special Configuration Not Covered by Model Nomenclature
31		

**Note:** Not all options are available with all configurations. Contact your Marvair sales representative for configuration details and feature compatibility.

### 1.4 Air Flow, Weights and Filter Sizes

Complete electrical and performance specifications and dimensional drawings are in the Marvair Wall Mount Air Conditioner Product Data Sheets.

**Note:** Follow local codes and standards when designing duct runs to deliver the required airflow. Minimize noise and excessive pressure drops caused by duct aspect ratio changes, bends, dampers and outlet grilles in duct runs.

Model	0.10	0.15	0.20	0.25	0.30	0.40	0.50
MAH1018A	685	670	670	642	640	<b>600</b>	
MAH1020A	800	785	770	725	680	<b>600</b>	
MAH1024A	800	785	770	725	680	600	<b>500</b>
MAH1030A	1200	1150	1100	1050	1000	900	<b>800</b>
MAH1036A	1290	1230	1170	1115	1060	1000	<b>920</b>
MAH1042A	1500	1430	1360	1295	1230	1160	<b>1070</b>
MAH1048A	1950	1900	1850	1815	1760	1680	<b>1590</b>
MAH1060A/MAH2072A & MGH1072A	1900	1850	1800	1700	1600	1500	<b>1350</b>

*Values in bold are the minimum air flow.*

Air flow ratings of 208-230 volt units are at 230v. Air flow ratings of 460 volt units are at 460 volts. Operation of units at a voltage different from the rating point will affect air flow. Marvair does not recommend operating at airflows lower than what is stated in this table

**Table 1. CFM @ External Static Pressure (Wet Coil) (IWG)**

Model	INCHES	MILLIMETERS	PART NUMBER	FILTERS PER UNIT	MERV RATING
MAH1018A	14 x 12 1	356 x 305 x 25	P/80122	1	N/A
MAH1020A/1024A	16 x 25 x 2	406 x 635 x 51	80137	1	8 (STD)
MAH1024A/1030A/1036A "B2" INTERNAL	16 x 30 x 1	406 x 762 x 25	80136	1	N/A
MAH1024A "B2" RETURN GRILLE	11½ x 19½ x 1	292 x 495 x 25	91983	1	N/A
MAH1030A/1036A & MAH2072A	18 x 30 x 2	457 x 762 x 51	93184	1	8 (STD)
MAH1030A/1036A "B2" RETURN GRILLE	27½ x 13½ x 1	699 x 343 x 25	80769	1	N/A
MAH1042A/1048A	36½ x 22 x 2	927 x 559 x 51	80162	1	8 (STD)
MAH1060A	18 x 24 x 2	457 x 610 x 51	81257	2	8 (STD)
MGH1072A	24 X 30 X 2	610 x 762 x 51	93587	1	8 (STD)

**Table 2. Return Air Filter Sizes**

Model	Weight	Base	w/Economizer	w/3 Phase	w/Economizer & 3 Phase
MAH1018A	Pounds (Kilograms)	265 (120)	N/A	N/A	N/A
MAH1020A/MAH1024A	Pounds (Kilograms)	337 (153)	357 (162)	356 (161)	376 (171)
MAH1024A/1030A "B2"	Pounds (Kilograms)	378 (171)	400 (181)	397 (180)	419 (190)
MAH1030A/MAH1036A	Pounds (Kilograms)	397 (180)	419 (190)	416 (189)	438 (199)
MAH1036A "B2"	Pounds (Kilograms)	380 (172)	403 (183)	418 (190)	441 (200)
MAH1042A/MAH1048A	Pounds (Kilograms)	453 (205)	476 (216)	491 (223)	514 (233)
MAH1060A	Pounds (Kilograms)	469 (213)	492 (223)	522 (237)	545 (247)
MAH2072A	Pounds (Kilograms)	717 (325)	740 (336)	770 (349)	793 (360)
MGH1072A	Pounds (Kilograms)	583 (264)	606 (275)	636 (288)	659 (299)

**Table 3. Installed Weights for Marvair Wall Mount AC Units**

Model	Ventilation Configuration	Temperature Range
Non-Economizer	Standard ("N"), Desert Duty ("ND")	0°F – 131°F (-18°C – 55°C)
With Economizer	Standard ("CE"), Desert Duty ("CD")	-40°F – 131°F (-40°C – 55°C)

**Table 4. Ambient Temperature Operating Range**

Model	Refrigerant Charge (Oz)	Model	Refrigerant Charge (Oz)
MAH1018A	55	MAH1042A	112
MAH1020A	76	MAH1048A	112
MAH1024A	76	MAH1060A	105
MAH1024-1030A "B2"	110	MAH2072A	135
MAH1030A	90	MGH1072A	135
MAH1036A & "B2"	90	MGH2072A	135

**Table 5. Refrigerant Charge (R454B, Ounces)**

		MAH1020A	MAH1024A	MAH1030A	MAH1036A	MAH1042A	MAH1048A	MAH1060A	MGH1072A
Minimum Room Size (ft <sup>2</sup> )	Top Supply	74.6	74.6	88.4	88.4	110.0	110.0	103.1	132.5
	Center Supply	146.4	146.4	173.4	173.4	215.8	215.8	202.3	260.1
Minimum Supply Height (ft)	Top Supply	6.9	6.9	6.9	6.9	6.9	6.9	6.9	6.9
	Center Supply	3.5	3.5	3.5	3.5	3.5	3.5	3.5	3.5
		MAH2024A	MAH2030A	MAH2036A	MAH2042A	MAH2048A	MAH2060A	MGH2072A	
Minimum Room Size (ft <sup>2</sup> )	Top Supply		93.3	88.4	103.1	120.8	125.7	122.7	147.3
	Center Supply		183.1	173.4	202.3	237.0	246.7	240.9	289.0
Minimum Supply Height (ft)	Top Supply		6.9	6.9	6.9	6.9	6.9	6.9	6.9
	Center Supply		3.5	3.5	3.5	3.5	3.5	3.5	3.5

**Table 6. Room Size Limitations**

Altitude (Meters)	Altitude (Feet)	Correction Factor
0	0	1.0
200	660	1.0
400	1310	1.0
600	1970	1.0
800	2620	1.0
1000	3280	1.1
1200	3940	1.1
1400	4590	1.1
1600	5250	1.1
1800	5910	1.2
2000	6560	1.2
2200	7220	1.2
2400	7870	1.3
2600	8530	1.3
2800	9190	1.3
3000	9840	1.4
3200	10500	1.4
3400	11150	1.5
3600	11810	1.5
3800	12470	1.6
4000	13120	1.6
4200	13780	1.7
4400	14440	1.7
4600	15090	1.8
4800	15750	1.9
5000	16400	1.9

In accordance with UL 60335-2-40, for units above 600m, multiply the minimum room area stated in the table above by the correction factor that corresponds with the altitude the unit is located at. This will give you a new minimum room area that is adjusted for your altitude. The units listed in this manual are not intended for use above 5000 meters.

**Table 7. Altitude Correction Factor**

## 1.5 General Operation

### Refrigerant Cycle (Cooling Mode)

Marvair air conditioners use R-454B refrigerant in a conventional vapor-compression refrigeration cycle to transfer heat from air in an enclosed space to the outside. A double blower assembly blows indoor air across the evaporator. Cold liquid refrigerant passing through the evaporator is boiled into gas by heat removed from the air. The warmed refrigerant gas enters the compressor where its temperature and pressure are increased. The hot refrigerant gas condenses to liquid as heat is transferred to outdoor air drawn across the condenser by the condenser fan. Liquid refrigerant is metered into the evaporator to repeat the cycle.

### Heating Mode

A wall-mounted thermostat controls the heating cycle of models which incorporate resistance heating elements. On a call for heat, the thermostat closes the heat relay to energize the indoor fan and the resistance elements. Except on units with the optional dehumidification kit, the compressor is locked out during the heating cycle. Please see Appendix A for instructions on field installing electric heaters.

### **Economizer Operation**

The economizer is a regulated damper system with controls. The damper regulates the circulation of outside air into the enclosure (when the outdoor air conditions are suitable) to reduce the need for mechanical cooling, save energy, and extend compressor life.

Depending upon the options selected, the damper responds to the enthalpy of the outdoor air. On a call for cooling from a space thermostat, it operates as follows:

When the enthalpy of the outdoor air is below the set point, the outdoor air damper is proportionally open (and return air damper is proportionally closed) to maintain between 50°F and 56°F (10°C to 13°C) at the mixed/discharge air sensor. Integral pressure relief allows the indoor air to exit the shelter through the air conditioner.

When the enthalpy of the outdoor air is above the set point, the outdoor air damper closes to its minimum position. A call for cooling from the space thermostat brings on mechanical cooling.

A built-in adjustable minimum position potentiometer controls the amount of outdoor air admitted to meet minimum ventilation requirements.

## **1.6 Optional Controls & Packages**

### **Hard Start Kit**

Used on single phase equipment to give the compressor higher starting torque under low voltage conditions.

### **Protective Coating Packages**

Typically only the non-economizer units are used in corrosive environments, but the air conditioners with an economizer is also available with corrosion protection. Two corrosion protection packages are offered- one for the condenser section (the Coastal Environmental package) and the other for the entire unit (the Coat-All Package).

The Coastal Environmental Package includes:

- Corrosion resistant fasteners
- Sealed or partially sealed condenser fan motor
- Protective coating applied to all exposed internal copper and metal in the condenser section
- Protective coating on the condenser coil (Luvata Insitu®) contains ES2 (embedded stainless steel pigment) technology.

The Coat all Package includes all of the above, plus:

- Protective coating on the evaporator coil (Luvata Insitu®) contains ES2 (embedded stainless steel pigment) technology
- Protective coating on exterior and interior components and sheet metal. (Note: the internal sheet metal which is insulated, bottom outside panel, and the internal control box are not coated)

### **Electric Reheat Dehumidification**

A humidity controller allows electric heat and cooling to operate simultaneously. Marvair® air conditioners equipped with the dehumidification option allow the indoor humidity of the controlled environment to be maintained at or below a certain humidity set point. These units do not have the ability to add humidity to the building.

## **IMPORTANT**

**The electrical wire and breaker or fuses must be sized for simultaneous operation of the electric heater and the air conditioner. Refer to the data sticker on the unit or the appropriate Air Conditioner Product Data Sheet for the sizing information.**

Dehumidification is achieved by operating mechanical cooling in conjunction with electric reheat. The strip heat is sized approximately to the sensible capacity of the total tonnage of the machine (i.e., on a 24,000 BTU unit the strip heat is sized at approximately 20,000 BTU). Because the strip heat is sized to the approximate sensible cooling capacity, only selected models are available.

#### *Operation:*

When the humidity rises above the set point on the humidity controller both mechanical cooling and electric reheat operate to temper the air and lower the humidity. If the temperature in the controlled environment rises above the set point of the thermostat and the unit is operating in the dehumidification mode, the call for cooling will override the call for dehumidification and the strip heat is disengaged until the thermostat is satisfied. This assures the environment temperature is maintained as first priority and humidity control is second.

In applications where a shelter has redundant air conditioning units and is controlled by a lead lag controller (CommStat Touch, CommStat 4, CommStat 3 HVAC Controller), most times the dehumidification option is only necessary on one of the two units. It is possible for one unit to be operating in the cooling mode while the unit with dehumidification is operating at the same time. If the cooling unit does not maintain the shelter temperature set point, the unit with dehumidification will go into the cooling mode. It does not matter whether the unit with dehumidification is the lead or lag unit.

#### **Three Phase Voltage Monitor**

Continuously measures the voltage of each of the three phases. The monitor separately senses low and high voltage, voltage unbalance including phase loss and phase reversal. An LED indicator glows when all voltages are acceptable. Automatically resets when voltages and phases are within operating tolerances. Not required on 1Ø units.

#### **Dirty Filter Indicator**

A diaphragm type of indicator measures the air pressure on either side of the filter and when the pressure drops below the set point, a red LED is illuminated. The set point is adjustable.

#### **Protective Coil Coatings**

Either the condenser or evaporator coil can be coated, however, coating of the evaporator coil is not common. For harsh conditions, e.g., power plants, paper mills or sites where the unit will be exposed to salt water, the condenser coil should be coated. Note: Cooling capacity may be reduced by up to 5% on units with coated coils.

#### **Thermal Expansion Valve**

Available on all Marvair air conditioners. Improves performance in hot ambient temperatures.

#### **High Filtration**

Selected units are built with larger blowers/motors for use with higher efficiency filters with MERV ratings of 11, 13 and 14 when tested to ASHRAE 52.2. Units with economizers have a pre-filter on the outside air.

#### **Lockable Disconnect Access Cover Plate**

The access plate to the service disconnect switch can be equipped with a lockable cover.

#### **Desert Duty**

The Desert Duty package is a factory installed package of components and cabinet modifications which permit operation in harsh environments. To prevent sand and dust infiltration, the electrical control box is sealed. A closed loop design on non-economizer units insures that no outside air is introduced into the shelter. Note: Units with an economizer may be ordered with the Desert Duty Package. If the air conditioner is required with the Desert Duty Package, sand intrusion into the shelter should be considered.

### **Cabinet Color and Material**

Marvair air conditioners are available in six different cabinet colors. The standard colors are Marvair® beige, white, gray and Carlsbad Canyon (brown). The standard cabinet's sides, top and front panels are constructed of 20 gauge painted steel. Contact your Marvair representative for color chips. Custom colors are also available; contact Marvair for details.

Two stainless steel cabinet constructions are available:

**Stainless Steel Exterior (Option “5”):** This option replaces all standard exterior painted surfaces with stainless steel. This option also replaces the standard unpainted compressor base of the unit and exterior cabinet screws with stainless steel. No other standard construction surfaces are stainless steel in this option, unless listed in this description. Back panel is not stainless steel with this option. This option is designed to give a more economical alternative to full stainless steel, and still offer an enhanced level of protection. For further corrosion protection, please see our “A” offering at full stainless on all metal components.

**Stainless Steel Unit (Option “A”):** This option replaces all interior and exterior steel sheet metal parts with stainless steel. All galvanized and painted steel surfaces found in the standard unit are stainless steel with this option. All cabinet screws are stainless steel. No other standard construction surfaces are stainless steel, unless listed in this description. This option is designed to give our most robust protection against steel corrosion.

## **1.7 Electrical Operation**

The compressor and condenser fan are energized with a contactor controlled by a 24 VAC pilot signal.

Some compressors incorporate an internal PTC crankcase heater that functions as long as primary power is available. The heater drives liquid refrigerant from the crankcase and prevents loss of lubrication caused by oil dilution. Power must be applied to the unit for 24 hours before starting the compressor.

The condenser (outside fan) motor is energized by the same contactor. However, the motor is cycled on and off by the low ambient control (see low ambient control 1.6).

The indoor evaporator fan motor is controlled by the fan purge on the electronic control board.



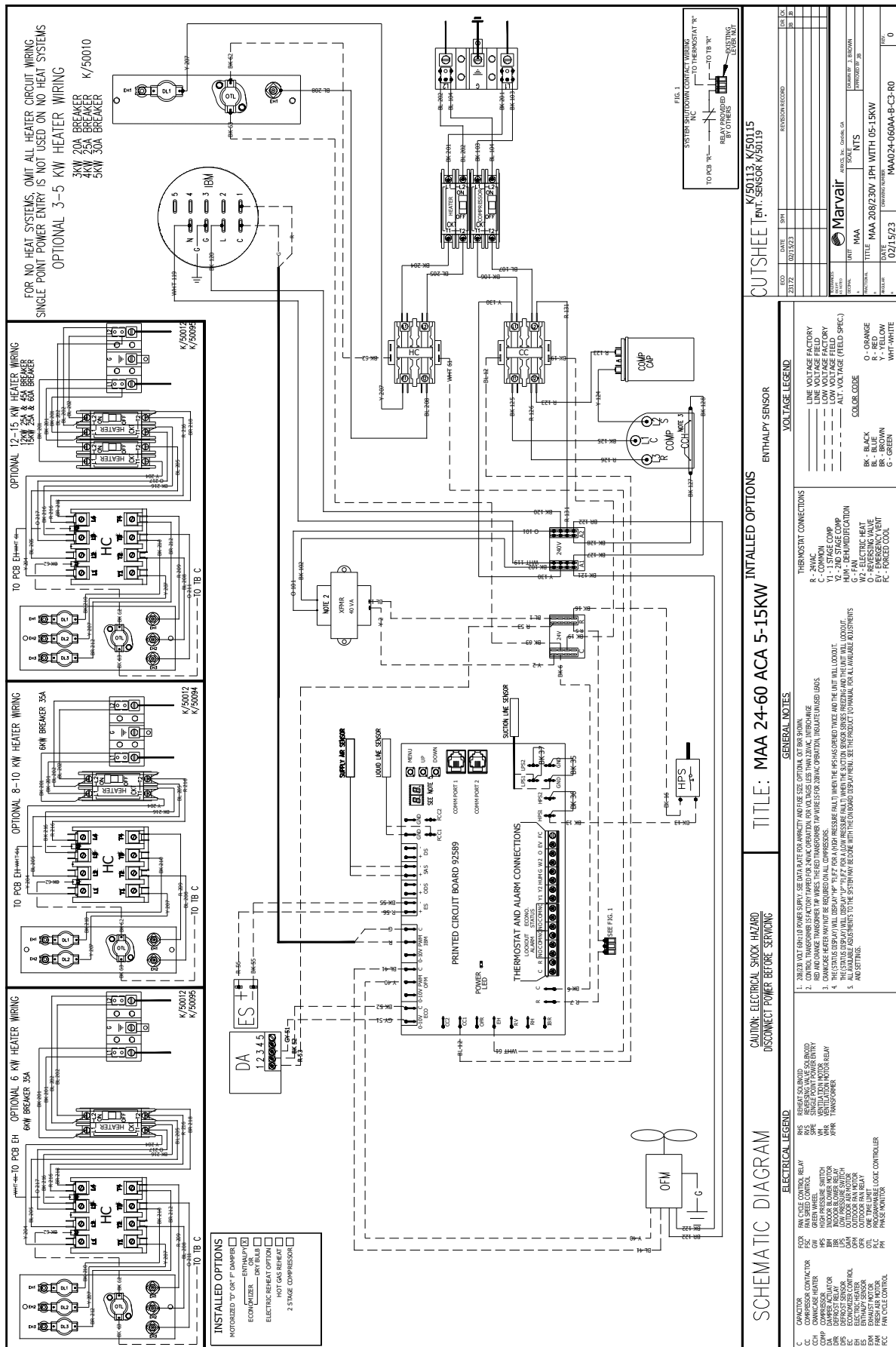

Figure 1b. Typical Electrical Schematic - (Economizer) Model MAH







# Chapter 2 Electronic Control Board

## 2.1 Introduction



**WARNING**

**Failure to observe the instructions contained in this document may result in personal injury and/or property damage and may void the warranty. Read this manual before installing, replacing or using this product.**

Marvair’s proprietary Printed Circuit Board (PCB) sets the standard for the industry in flexibility, reliability and performance. This UL certified component is engineered to optimize Heating, Cooling and Dehumidification operation while communicating valuable information to the end user. Special features include 2-Stage operation with varying speed control to optimize latent and sensible capacity, built in remote communication (Modbus) for monitoring and/or control, optimized head pressure control and configurable menu options for various operations and control. The Marvair PCB comes equipped with seven segment display to annunciate faults, which drastically reduces troubleshooting time and system downtime. Lockout contacts are also provided along with the alarms being transferred via Modbus.

This chapter provides the necessary information for installing and operating the Marvair PCB. The diagram below identifies the inputs, outputs and connections for the Marvair PCB. *See I/O table.*

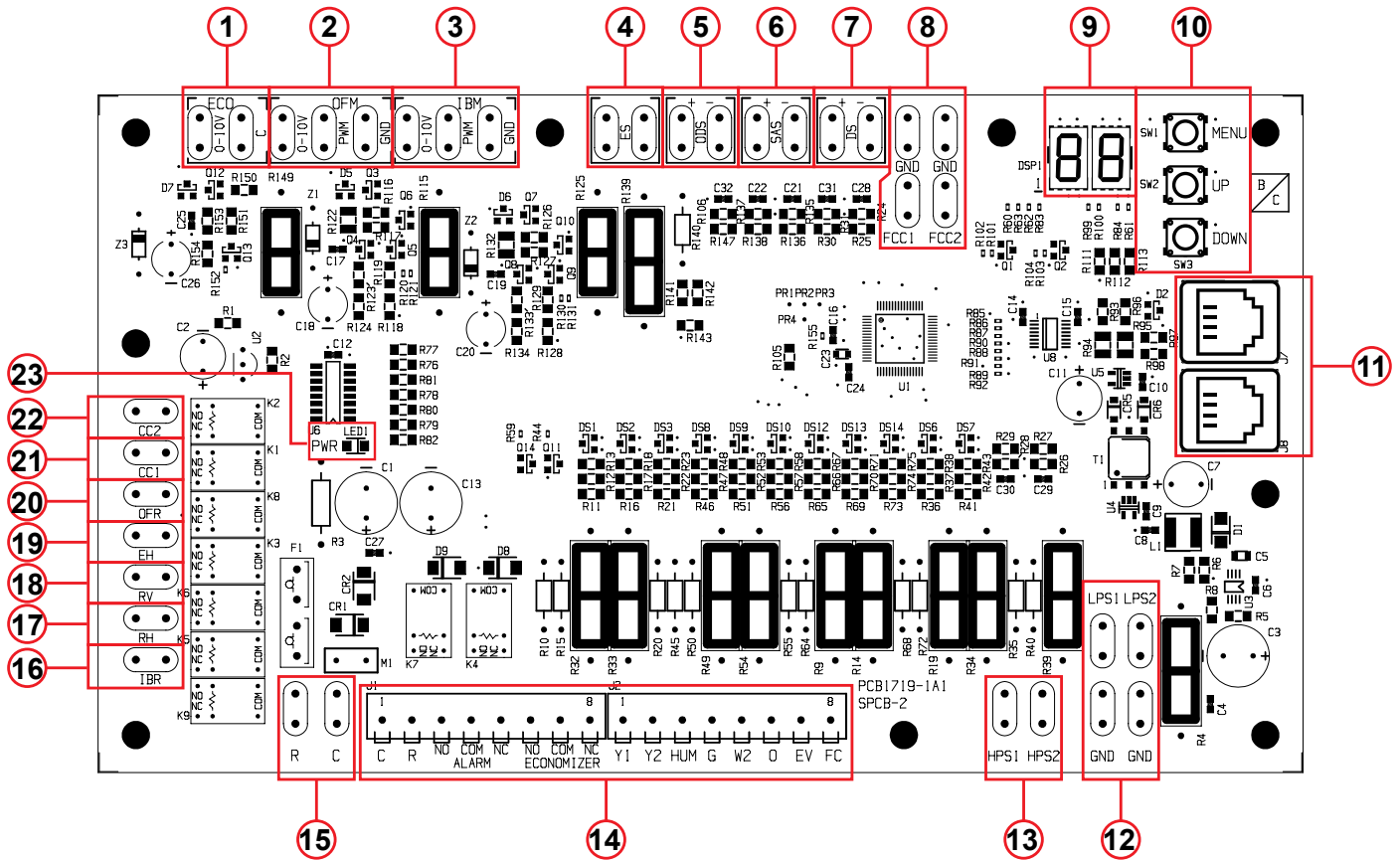

**NOTE:** The FC Input has been repurposed for A2L Input on Version 17 Board Software  
Use the Y2 Input for Forced Cooling on version 17 and later Boards.

I/O Table for Control Board	
Item	Description
1	Economizer Actuator Output 2-10 VDC
2	Outdoor Motor Control Output 0-10 VDC or PWM
3	Indoor Motor Control Output 0-10 VDC or PWM
4	Enthalpy Sensor Signal Input 4-20mA
5	Outdoor Sensor Signal 10K NTC (Heat Pumps) / Dry Bulb Sensor Signal Input 10K NTC (Systems Equipped with Dry Bulb Economizer)
6	Supply Air Sensor Signal Input 10K NTC (Systems Equipped with Economizer)
7	Defrost Sensor Signal Input 10k NTC (Heat Pumps Only)
8	Head Pressure Control Sensor Signal 10k NTC (ECM Motors)
9	Control Board Menu/Fault Display
10	Menu/Up/Down Selection Buttons
11	Modbus RJ11 Communications Ports
12	LPS 1 = Freeze Sensor Input 10K NTC   LPS 2 = Not currently used (Software version 16 and later)
13	HPS 1 = High Pressure Switch Input (Normally Closed) HPS 2 = Low Pressure Switch Input (Normally Closed) (Software Version 16 and later)
14	Thermostat Inputs/Alarm And Status Terminals
15	24 VAC To Power Board (18 VAC To 30 VAC)
16	Indoor Blower Output 24 VAC (PSC Motors)
17	Reheat Output 24 VAC (Hot Gas Or Electric Reheat Dehumidification)
18	Reversing Valve Output 24 VAC (Heat Pumps Only)
19	Electric Heat Output 24 VAC
20	Outdoor Fan Output 24 VAC (PSC Motors)
21	Compressor 1/1st Stage Output 24 VAC (Single Stage Compressor)
22	Compressor 2/2nd Stage Output 24 VAC (Dual Compressor System 2nd Compressor) (Single Compressor 2nd Stage)
23	Control Board Power Indicator LED

## 2.2 Installation and Replacement

The PCB is factory installed. To install a replacement PCB, use the six mounting holes along with the appropriate screw size to firmly secure the board to the control box. After this is achieved, follow the wiring diagram and menu configuration for the respective system for appropriate operation. Ensure that the terminals used do not make any unwanted electrical connection (via strands etc.) with any other terminals. Please allow a 1” creepage distance between the board and all other adjacent electrical components.

## 2.3 PCB Details and Information

The PCB is equipped with an on board seven-segment display (Item #9) for configuring various settings and displaying faults. During normal operation the display remains off unless the configuration menu is accessed or a fault has occurred. Faults will be annunciated on the display as shown below:



Display	Displayed Faults
<b>A2</b>	A2L Sensor Fault / Disconnected Sensor
<b>AS-F</b>	Supply Air Sensor Fault (sensor disconnected or faulty) if equipped
<b>DB-F</b>	Dry Bulb / Outdoor Sensor Fault (sensor disconnected or faulty) if equipped
<b>DS-F</b>	Defrost Sensor Fault (sensor disconnected or faulty) Heat Pumps Only
<b>ES-F</b>	Enthalpy Sensor Fault (sensor disconnected or faulty) if equipped
<b>EF</b>	Emergency Fan / Ventilation Active
<b>FS</b>	Freeze Sensor Fault
<b>LP-1F</b>	Low Pressure Lockout
<b>HP-Lc</b>	High Pressure / Loss of Charge Lockout
<b>o3</b>	Low Voltage "Brownout" 16vac or less for 10 minutes

### 2.3.1 – Programming Menu Configuration

1. To Enter Programming Mode:
  - Press and hold the *Menu* button for 5 seconds until **P-01** is displayed.
2. While in Programming Mode main menu:
  - Press the *Menu* button to enter the displayed parameter menu.
  - Press the Up/Down buttons to adjust the current parameter number.
  - The current parameter number will be displayed seven segments alternating showing "P-" and the number every 0.5s.
3. While in parameter menu:
  - The current parameter selection will be displayed seven segments.
  - Press the *Menu* button to save the current parameter selection return to the programming main menu.
  - Press the Up/Down buttons to adjust the current parameter selection.
4. To exit programming mode, press and hold the *Mode* and *Up* buttons while in the programming main menu.
  - Press and hold the *Menu* button for 5 seconds.
  - **Note:** The control will automatically exit the programming mode after 2 minutes with no activity.

**Note:** 100 will be displayed by alternating between "1" and "00" every 0.5s.

Configuration Menu				
Menu Setting	Name	Default	Selections	General Description-
1	System Type	AC	AC, HP	HP = Heat Pump, AC = AC Unit (Factory Set)
2	IBM Select	P	P, DC	P = PWM, DC = 0-10V (Factory Set)
3	Fan Purge	90	N, 10-90	IBM P = PWM, dC = 0-10V and IBR Off Delay in Seconds
4	IBM G Set	60	30-100	G Call for Indoor Blower Speed Setting
5	IBM Y1 Set	60	40-100	1st Stage Cooling Indoor Blower Speed Setting
6	IBM Y2 Set	80	40-100	2nd Stage Cooling Indoor Blower Speed Setting
7	OFM Select	P	P, DC	P = PWM, DC = 0-10V (Factory Set)
8	OFM Set	80	65-100	Outdoor Fan Motor Max Speed Setting
9	Defrost Timer	30	30, 60, 90	Defrost cycle timer in minutes
10	EHDD Select	Y	Y, N	CAN ONLY BE "Y" IF SCKT IS "N" (Electric Heat During Defrost)
11	SCKT Select	N	Y, N	SCKT= Y OVERRIDES EHDD (Safety Circuit)
12	ODS Set	30	30-50	Outdoor Sensor Switch to Electric Heat Below Setpoint (Heatpump Only)
13	ECONO Select	N	Y, N	N = Disabled (No Econo.), Y = Enabled (W/Econo.)
14	Sensor Type	EN	EN or DB	Economizer sensor type selection EN= Enthalpy, DB = Dry Bulb
15	ECONO Set	D 70	A-E 20F - 105F	Selections A=73F, B=70F, C= 67F, D =63F E= 55F all @ 50%RH (Only available if EN sensor type is selected) Dry Bulb 20F to 105F
16	MIN POS	20	20-100	Sets the damper position for Minimum Open
17	W2 Speed	100	70-100	Sets the Indoor Blower Speed for Electric Heat
18	Dehum Speed	80	60-100	Sets the Indoor Blower Speed for Dehumidification
19	Pulse Reheat	Y	n/Y	Y = Pulsing reheat @ Dehum Supply Set N= On/Off reheat
20	Dehum Supply Set	72	70-75	Supply Air Setpoint for Dehumidification w/ 5F off differential
21	DS Calibration	0	-18	Defrost Sensor Calibration
22	MAS Calibration	0	-18	Supply Air Sensor Calibration
23	T'STAT Select	H	H, C	H = hardwired 24V tstat, C = communicating tstat
24	MODBUS ID	1	1 to 99	Sets the Modbus ID for the unit
25	MODBUS BAUD rate	19	9.6, 19	Available Baud Rates 9.6 = 9600, 19 = 19200
26	MODBUS Timeout	10	1 to 60	Communications Timeout in minutes
27	Head Press. Cutout	85	75-95	Sets Head Press Min Cutout Temp adjustable in 1F increments
28	OFM Speed Heating	85	65-100	Outdoor Fan Motor Max Speed Setting Heat pump Heating Only
29	Test	N	Y,N	Set to "Y" all timers are reduced for testing (Resets after 10 min.)
30	SW Version Number	N/A	N/A	Displays the current version software

## Configuration Menu Details

1. **System Type:** This setting allows the PCB to be configured for AC (air-conditioner) or HP (heat-pump). The system type is configured at the factory during production testing for the appropriate system type. The default system type is AC.
2. **IBM Select:** This setting allows the IBM (Indoor Blower) control signal to be configured for PWM or 0-10vdc control. The default control output signal is PWM.
3. **Fan Purge:** This setting allows the delay off time of the indoor blower once the call for the indoor blower has been removed. The selections are N (no delay) or 10-90 seconds. After the default time of 90 seconds the indoor blower will shut off. Selecting the N (no delay) will allow the Indoor blower to shut off immediately after any request has been removed.
4. **IBM G Set:** This is an independent setting for the speed at which the Indoor blower will operate upon a request for G (Fan Only) via Digital Input or MODBUS. The default setting for the IBM G Set is 60% of maximum speed. The speed may be adjusted from 30-100% in 1% increments to meet desired airflow requirements.
5. **IBM Y1 Set:** This is an independent setting for the speed at which the Indoor blower will operate upon a request for Y1 (1st stage cooling) via Digital Input or MODBUS. The default setting for the IBM Y1 Set is 80% of maximum speed. The speed may be adjusted from 40-100% in 1% increments to meet desired airflow requirements.

*Note:* Adjusting the speed too low will result in coil freezing.

6. **IBM Y2 Set:** This is an independent setting for the speed at which the Indoor blower will operate upon a request for Y2 (2nd stage cooling) via Digital Input or MODBUS. The default setting for the IBM Y1 Set is 100% of maximum speed. The speed may be adjusted from 40-100% in 1% increments to meet desired airflow requirements.

*Note:* Adjusting the speed too low will result in coil freezing, low-pressure or high-pressure lockout.

7. **OFM Select:** This setting allows the IBM (Indoor Blower) control signal to be configured for PWM or 0-10vdc control. The default control output signal is PWM.
8. **OFM Set:** This is an independent setting for the max speed at which the Outdoor fan will operate. The default setting for the OFM Set is 80% of maximum speed. The speed may be adjusted from 65-100% in 1% increments to meet desired airflow requirements.

*Note:* Adjusting the speed too low will result in coil freezing, low-pressure or high-pressure lockout.

9. **Defrost Timer:** The defrost timer only applies to Heat-pump systems (when setting 1 is set to HP). This is the accumulation timer used to monitor for heat-pump defrost control. The selections for defrost timing is 30, 60 and 90 minutes. The defrost timer accumulates the compressor runtime in the heat-pump mode and monitors the defrost sensor for freezing conditions to initiate a defrost cycle at the selected defrost timing interval. The default defrost time is 30 minutes.

10. **EHDD Set:** The Electric heat during defrost setting allows the electric heat to operate when a defrost cycle is being performed in heat-pump mode. The selections for the EHDD Set are Y (yes) or N (no). When set to N (no) the electric heat will not operate automatically during a defrost cycle in heat-pump mode. When the EHDD Set is set to Y (yes, Default) the electric heat will operate upon each defrost cycle in the heat-pump mode.

*Note:* EHDD and SCKT cannot both be set to the Y (yes) selection at the same time. SCKT takes priority over EHDD.

11. **SCKT Set:** The SCKT setting is used to prevent simultaneous operation of the electric heat and compressor. The selections for the SCKT Set are Y (yes) or N (no). When set to N (no, Default) the electric heat will be allowed to operate with the compressor in heat-pump mode upon a call for W2 (auxiliary / emergency heat). When the SCKT Set is set to Y (yes) the electric heat will

not be allowed to operate with the compressor in the heat-pump mode. When set to Y (yes) and upon a request for W2 (auxiliary / emergency heat) the compressor will shut off and the electric heat will operate.

**Note:** SCKT and EHDD cannot both be set to the Y (yes) selection at the same time. SCKT takes priority over EHDD.

12. **ODS Set:** The ODS Set is used to set the Outdoor Sensor temperature for Heat-pump systems. When the system type is configured for Heat-pump (when setting 1 is set to HP), the ODS Set allows the outdoor sensor to be used to switch from Heat-pump Heating to Electric Heat when the outdoor temperature is below the ODS setpoint. The ODS setpoint has an adjustable range from 30F-50F in 1F increments with a default setpoint of 30F. If the ODS sensor is not connected to the PCB, the ODS Sensor is ignored.
13. **ECONO Select:** The ECONO Select is used to select whether the system has an economizer system installed or not. When set to the Y (yes) selection the system will include the economizer cooling algorithm within its sequence of operation and utilize the economizer package when conditions are favorable for economizer cooling. When set to the N (no) selection the system will only utilize the compressor for cooling operation. This setting is configured at the factory during production testing for the appropriate system type. **Note: When ECONO Set is set to Y (yes) the system must have an Enthalpy or Dry Bulb and Supply Air sensor connected and properly selected in setting 14 in order to operate in economizer cooling. The system will default to compressor cooling if any sensor becomes disconnected or faulty. Changing the ECONO Select to N (no) will disable economizer operation and the economizer function will be ignored.**
14. **Sensor Type:** This setting is used for selecting the type of economizer sensor used EN (Enthalpy) or DB (Dry Bulb). The appropriate sensor must be connected and selected for economizer operation. This setting is configured at the factory during production testing for the appropriate sensor type.
15. **ECONO Set:** This setting is used to set the economizer setpoint at which the economizer is allowed to operate for cooling. When setting 14 is set for EN (Enthalpy), the selections are A=73°F, B=70°F, C=67°F, D=63°F and E=55°F all at 50% relative humidity. The A – E selections will only be available when setting 14 is set to EN (Enthalpy). When setting 13 is set for DB (Dry Bulb), the selection is from 20°F to 105°F in 1°F increments. The 20°F-105°F range will only be available when setting 14 is set to DB (Dry Bulb).
16. **MIN POS:** The MIN POS setting is for setting the minimum position of the economizer or motorized damper. When set above 20 (2vdc) the damper will remain open to the selected position at all times, hence minimum position. The adjustable range is from 20 (2vdc) to 100 (10vdc) in 1vdc increments.
17. **W2 Speed:** This is an independent setting for the speed at which the Indoor blower will operate upon a request for W2 (Electric heat) via Digital Input or MODBUS. The default setting for the W2 speed is 100% of maximum speed. The speed may be adjusted from 70-100% in 1% increments to meet desired airflow requirements.  
**Note:** Adjusting the speed too low will result in increased supply air temperatures in electric heat mode.
18. **Dehum Speed:** This is an independent setting for the speed at which the Indoor blower will operate upon a request for HUM (Dehumidification) via Digital Input or MODBUS. The default setting for the Dehum speed is 80% of maximum speed. The speed may be adjusted from 60-100% in 1% increments to meet desired airflow requirements.
19. **Pulse Reheat:** This setting allows the dehumidification output “RH” to be cycled On and OFF based on the Dehum Supply temperature setpoint. The Options are Y= Yes or N= No and the default is Y.

20. **Dehum Supply Set:** This setting allows the target setpoint for the supply air temperature during dehumidification operation. The setpoint range is adjustable from 70°F to 75°F with a fixed differential of 5°F. The default setpoint is 72°F
21. **DS calibration:** This setting is used to calibrate the defrost sensor from 0° to -18°F.
22. **SAS calibration:** This setting is used to calibrate the supply air sensor from 0° to -18°F.
23. **T'STAT Select:** The thermostat type can be selected with this setting for an option of H= Hardwired 24vac Thermostat or C = Communicating Thermostat via Modbus. The default setting is H= Hardwired 24vac Thermostat.
24. **Modbus ID:** This setting allows the Modbus ID to be entered for Modbus communications for the unit. The range for the Modbus ID is 1 – 36161 the default Modbus ID is 1.
25. **Modbus Baud Rate:** This setting allows the Modbus Baud Rate to be entered for Modbus communications. The available Baud Rates are 9.6= 9600 and 19= 19200. The default Modbus Baud Rate is 19 = 19200.
26. **Modbus Timeout:** This is the setting for the Modbus communications timeout in minutes. The range of communications timeout is from 25 minutes to 21916 minutes. The default communications timeout is 25 minutes.
27. **Head Pressure Cutout:** This setting allows the cutout temperature for head pressure control to be adjusted from 75°F to 95°F in 1°F increments. The Liquid line sensor is monitored for head pressure control to modulate the outdoor fan motor. When the sensor temperature reaches the cutout setpoint, the outdoor fan will begin operation. As the liquid line temperature rises the speed of the outdoor fan will increase as needed to maintain a minimum operating speed. The outdoor fan will decrease speed as the temperature decreases closer to the cutout setpoint until the liquid line temperature drops below the head pressure control cutout setpoint. The default head pressure control cutout temperature is 85°F.
28. **OFM Speed Heating:** This setting allows the Outdoor Motor speed to be adjusted 65 – 100% in 1% increments in Heat-pump Heating operation. The default setting for the OFM Speed Heating is 85%.  
*Note:* Adjusting the speed too low may result in excessive defrost cycles in Heat pump operation.
29. **Test:** The Test feature has two options Y= Yes or N= No. When this setting is set to Y=Yes, all circuit timers are reduced to expedite testing for various system operations. When set to N=No, all circuit timers are used in their default configuration and normal operation.
30. **Software Version Number:** The software version of the 92589-control board will be displayed on the seven-segment display. This is for informational purposes only.

## 2.4 Operation

### Power

The Marvair PCB requires 24 VAC to operate. When the board is sufficiently powered, the “PWR” status light on the PCB illuminates “Green.” When the power supply voltage is 16vac or less for 10 seconds the control board will de-energize all outputs. This is considered a voltage brownout (low voltage) condition and the display of the control board will show “03” as an indicator of brownout (low voltage). When the voltage rises back to 17 VAC, the control board will allow the system to operate.

*Note:* The nominal power supply for the control board is 24 VAC and this voltage should be confirmed during startup to assure normal operation.

### Communication

The Marvair PCB comes equipped the Modbus communications standard. There are 2 adjacent RJ11 Modbus communication ports connected in parallel. That is, both ports transmit the same information.

The board allows you to set the Baud Rate at 9600 bits per second or 19200 bits per second. The board also allows the Modbus ID to be selected in the configuration menu with the available range from 1 to 36161. The default Modbus ID is 1. *See section 2.1 for reference.*

## 2.5 Sequence of Operation

### IMPORTANT

**All equipment should go through the recommended commissioning/start up sequence to ensure safety and system reliability. This document is only valid if the system is used as intended.**

This section defines the manner and method of control of the HVAC system. It will cover the following operations and protections.

### 1.0 Indoor Blower Operation

- 1.1 G - Indoor Blower Only
- 1.2 Y1 - Indoor Blower Operation
- 1.3 Y2 - Indoor Blower Operation
- 1.4 W2 – Indoor Blower Operation
- 1.5 HUM – Indoor Blower Operation

### 2.0 Cooling Operation AC / HP

- 2.1 Mechanical Cooling (AC systems)
  - 2.1.1 Partial Capacity
  - 2.1.2 Full Capacity
- 2.2 Mechanical Cooling (HP systems)
  - 2.2.1 Partial Capacity
  - 2.2.2 Full Capacity

### 3.0 Economizer Operation

- 3.1 Enthalpy Sensor and Operation
- 3.2 Dry Bulb Sensor and Operation
- 3.3 Supply Air Sensor
- 3.4 Minimum Position

### 4.0 Heating Operation AC / HP

- 4.1 Electric Heat (AC systems)
- 4.2 Heat Pump Heating Operation
- 4.3 Defrost Operation (Heat Pumps)
- 4.4 Electric Heat / Outdoor Sensor / SCKT / EHDD (Heat Pumps)

### 5.0 Dehumidification Operation AC / HP

- 5.1 Hot Gas Reheat
- 5.2 Electric Reheat
- 5.3 Pulse Reheat

### 6.0 Refrigeration Protection

- 6.1 High Pressure lockout
- 6.2 Low Pressure Lockout / Freeze Protection
- 6.3 Loss of Charge / Flat Unit Fault
- 6.4 Freeze Sensor Protection
- 6.5 Anti Short Cycle

## 7.0 Additional Features

- 7.1 Modulating Head pressure Control (ECM Outdoor Motors)
- 7.2 Emergency Ventilation
- 7.3 Forced Cooling Using Y2 Input (Formerly "FC")
- 7.4 Modbus Communications
- 7.5 Low Voltage (Brownout)

## 8.0 Smoke / Fire Shutdown

- 8.1 System Shutdown Contact Wiring

**Note:** Equipment, devices and necessary system components are specified in the respective section.

**Note:**

1. All inputs on the control board go through a 5 seconds Time-On Delay to prevent nuisance request. Compressor Outputs go through 5 seconds staggered Time On delay to prevent nuisance tripping of breaker due to the inrush associated with these large inductive loads.
2. Normal Operating Mode describes a mode in which there are no active faults which would interrupt the operation of the system.

### 1.0 Indoor Blower Operation

The speed at which the indoor blower will operate is based on the discrete operational inputs that have 24vac applied. These inputs are listed below.

- 1.1 G Input** – A request for Fan Only (independent G-signal via Digital input or Modbus), results in the indoor motor turning “ON” and operating at the "G" motor speed (Only Applicable for EC motors).
- 1.2 Y1 Input** – A request for Y1 (independent Y1-signal via Digital input or Modbus), results in the indoor motor turning “ON” and operating at the “Y1” motor speed (Only Applicable for EC motors).
- 1.3 Y2 Input** – A request for Y2 (independent Y2-signal via Digital input or Modbus), results in the indoor motor turning “ON” and operating at the “Y2” motor speed (Only Applicable for EC motors).
- 1.4 W2 Input** – A request for W2 (independent W2-signal via Digital input or Modbus), results in the indoor motor turning “ON” and operating at the “W2” motor speed (Only Applicable for EC motors).
- 1.5 HUM Input** – A request for HUM (independent HUM-signal via Digital input or Modbus), results in the indoor motor turning “ON” and operating at the “HUM” motor speed (Only Applicable for EC motors).

When there is a request for Indoor Fan (G-input High) along with a request for cooling, heating or dehumidification, the G-Input becomes lowest priority. This means that in any combination involving the G-input, the speed associated to Fan Only will never take precedence.

The priority list from Highest to Lowest goes as follows:

1. Y2 - Request
2. Y1 - Request
3. W2 - Request
4. HUM - Request
5. G - Request

**Note:** The priority list above also describes the operation that takes precedence in the event that there is a request for all operations or a combination of operations. The controller will NOT energize the compressor outputs and the heater output simultaneously if configured for AC. The controller WILL energize the compressor outputs and the heater output simultaneously if configured for HP.

The speed at which the Indoor Fan Operates during Stage 1 (Y1) and Stage 2 (Y2) Cooling Request can be set directly at the board using the configuration menu settings 4 and 5. All requests are interlocked with the Indoor Fan and will run the Fan at the respective speed associated with the operation. This means that a lone call for Stage 1 (Y1) Cooling will automatically run the Indoor Fan at Stage 1 (Y1) Cooling Speed even without a request for Indoor Fan. This holds true for all request.

## **2.0 Cooling Operation**

<b>AC Systems Request</b>	<b>Active Input</b>	<b>Active Output</b>
Stage 1 Cooling (Fixed Compressor)	Y1	CC1 (Partial Capacity)
Stage 1 Cooling (2 Fixed Compressors)	Y1 or Y2	CC1 or CC2 Respectively (Partial Capacity)
Stage 1 Cooling (1 Staged Compressor)	Y1	CC1 (Partial Capacity)
Stage 2 Cooling (2 Fixed Compressors)	Y1 + Y2	CC1 + CC2 (Full Capacity)
Stage 2 Cooling (2 Staged Compressors)	Y1 + Y2	CC1 + CC2 (Full Capacity)

**2.1 Mechanical Cooling (AC systems)** – This section will describe the sequence of operation which takes place during Direct Expansion (DX) cooling from a control standpoint.

*Note:* The system type must be configured for “AC” operation in setting 1 of the configuration menu of the control board for proper AC system operation. This system type is selected at the factory and there’s no need to change this setting.

**2.1.1 Y1 Cooling (Partial Capacity 1st Stage)** – In normal operating mode, a request for “Stage1 Cooling” Y1-signal via Digital input or MODBUS), energizes Compressor 1 Relay Output (CC1) on the PCB. The controller provides a continuous control signal associated to the Indoor Fan Motor, that is proportional to the “Y1” speed setting on the board or via MODBUS. It also outputs a request dependent (based on FCC IN) control signal for the Outdoor Fan Motor (Only applicable to ECM motors). In Stage 1 Cooling operation, the compressor operates at partial capacity and the indoor fan remains on continuously but the outdoor fan modulates based on liquid line temperature. The Fan Cycle Control Sensor (Low Ambient Control Sensor) monitors the liquid line to maintain a 90°F liquid line temperature. When the liquid line temperature is below 80°F the outdoor fan will shut off. A liquid line temperature above 115°F will force the outdoor fan to operate at the maximum speed set on the control board for setting 8 in the configuration menu. The outdoor fan will speed up and slow down between liquid line temperature of 80°F and 115°F. Systems with (PSC Outdoor Motors) utilizes a Fan Cycle Switch which closes at 400 PSIG to energize the OFR (outdoor fan relay) to start the outdoor fan which runs until the switch reopens (at 290 PSIG). These outputs function as described until the Cooling setpoint is satisfied. This is considered as ON/OFF fan cycle control and the PSC motor will not modulate.

*Note:* Single Stage compressors operate at full capacity upon a request for Y1.

**2.1.2 Y1 and Y2 Cooling (Full Capacity 2nd Stage)** – If the space temperature continues to increase pass the defined differential, Stage 2 Cooling (Y2-input) is energized. Under normal operation, this energizes the Compressor 2 Output (CC2). The Indoor Fan motor, will operate at “Y2” speed instead of “Y1” speed since Y2 has higher priority. These outputs remain energized until the cooling setpoint is satisfied. Once the setpoint is satisfied, the Compressor and the Outdoor fan outputs are de-energized. The Indoor motor continues to run based on the fan purge timer setpoint (default 90 seconds) selected in setting 3 of the configuration menu of the control board.

*Note:* 2 Stage compressors require a request for Y2 to operate at full capacity in Cooling operation. All Air-conditioners and Heat Pump systems with 2 stage compressors are allowed 2 stage cooling operation.

**2.2 Mechanical Cooling (Heat Pump Systems Only)** – This section will describe the sequence of operation which takes place during Direct Expansion (DX) cooling from a control standpoint. The reversing valve (O Input) must be energized for Cooling operation on Heat Pump systems. There's a 5 second delay on the reversing valve output upon a call for "O".

**Note:** The system type must be configured for "HP" operation in setting 1 of the configuration menu of the control board for proper HP system operation. This system type is selected at the factory and there's no need to change this setting.

**2.2.1 Y1+ O Cooling (Partial Capacity 1st Stage)** – In normal operating mode, a request for "Stage1 Cooling" Y1 + O signal via Digital input or MODBUS), energizes the Reversing Valve Output (RV) and Compressor 1 Relay Output (CC1) on the PCB. The controller provides a continuous control signal associated to the Indoor Fan Motor, that is proportional to the "Y1" speed setting on the board or via MODBUS. It also outputs a request dependent (based on FCC IN) control signal for the Outdoor Fan Motor (Only applicable to ECM motors). In Stage 1 Cooling operation, the compressor operates at partial capacity and the indoor fan remains on continuously but the outdoor fan modulates based on liquid line temperature. The Fan Cycle Control Sensor (Low Ambient Control Sensor) monitors the liquid line to maintain a 90°F liquid line temperature. When the liquid line temperature is below 80°F the outdoor fan will shut off. A liquid line temperature above 115°F will force the outdoor fan to operate at the maximum speed set on the control board for setting 8 in the configuration menu. The outdoor fan will speed up and slow down between liquid line temperature of 80°F and 115°F. Systems with (PSC Outdoor Motors) utilizes a Fan Cycle Switch which closes at 400 PSIG to energize the OFR (outdoor fan relay) to start the outdoor fan which runs until the switch reopens (at 290 PSIG). These outputs function as described until the Cooling setpoint is satisfied. This is considered as ON/OFF fan cycle control and the PSC motor will not modulate.

**Note:** Single Stage compressors operate at full capacity upon a request for Y1.

**2.2.2 Y1 + Y2 + O Cooling (Full Capacity 2nd Stage)** – If the space temperature continues to increase pass the defined differential, Stage 2 Cooling (Y1+Y2+O input) is energized. Under normal operation, this energizes the Compressor 2 Output (CC2). The Indoor Fan motor, will operate at "Y2" speed instead of "Y1" speed since Y2 has higher priority. These outputs remain energized until the cooling setpoint is satisfied. Once the setpoint is satisfied, the Compressor and the Outdoor fan outputs are de-energized. The Indoor motor continues to run based on the fan purge timer setpoint (default 90 seconds) selected in setting 3 of the configuration menu of the control board.

**Note:** 2 Stage compressors require a request for Y2 to operate at full capacity in Cooling operation. All Air-conditioners and Heat Pump systems with 2 stage compressors are allowed 2 stage cooling operation.

**Note:** With staged compressors, a CC2 output without a CC1 output will neither result in partial capacity nor full capacity. Only CC1 output can achieve partial capacity. Both CC1 and CC2 outputs are required to achieve full capacity.

### **3.0 Economizer Operation (If Equipped)**

#### **Damper Actuator**

The damper actuator is a 24V motor that modulates the position of the damper blade. It is capable of driving a full 90 degrees within 90 seconds. The assembly has a spring return to close the damper during power outage.

**3.1 Enthalpy Sensor** – The enthalpy sensor responds to the total heat content of the outdoor air to provide the changeover to outside air for free cooling. The control board must be configured for proper operation of the economizer by selecting Y= Yes in the configuration menu setting 13. The sensor type must be selected in setting 14 for EN=Enthalpy. The desired changeover setpoint must be selected in setting 15 (default D=63°F@50% rh). Example of Enthalpy Sensor and Enthalpy curve is shown below.

*Note:* Selecting N=No in configuration setting 13 will disable economizer operation.

**⚠ DANGER**

**Sever hazard. The economizer contains moving parts capable of causing serious injury or death. Disconnect power before removing the covering panel.**



Enthalpy Setpoint is Setting 14 in control board configuration menu.

Options

- A= 73°F**
- B= 70°F**
- C= 67°F**
- D= 63°F**
- E= 55°F**

All settings are @ 50%Rh

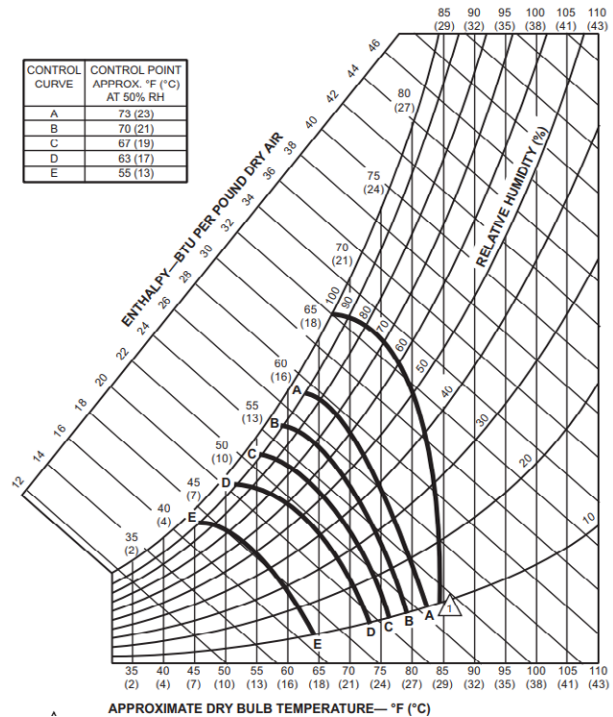

**Figure 2. Enthalpy Sensor & Temperature Control Points**

**Enthalpy Operation**

On a call for cooling from the wall-mounted thermostat, if outdoor conditions are suitable, the sensor will open the damper and admit outside air (i.e., economizer free cooling). If the outdoor ambient is too hot or humid (enthalpy sensor only), the sensor will place the actuator in the closed or minimum open position and activate mechanical cooling. The compressor is locked-out during the economizer cooling mode. The Supply Air sensor monitors the supply air of the system in economizer mode to modulate the economizer damper to maintain a 55°F supply air temperature.

During the testing of the air conditioner at the factory, the control board has been configured for the sensor type used in the system. There should be no need to change the sensor configuration. If an enthalpy sensor is being used, setting 14 of the control board configuration menu will be set for EN= Enthalpy. A disconnected or faulty enthalpy sensor is annunciated on the control board display as “ES-F”. Economizer operation is only allowed in Cooling Mode.

*Note:* A call for Y2 Inputs or a faulty or disconnected enthalpy sensor will override the economizer operation and force the compressor to operate.

**3.2 Dry Bulb Sensor** – The dry bulb sensor only responds to the dry bulb temperature of the outside air and ignores the humidity. The sensor is a 10K NTC sensor probe. The factory setting is 63°F. This setpoint can be adjusted in 1°F increments from 20°F to 105°F in the control board configuration menu setting 14. Example of the dry bulb sensor is shown below.

*Note:* Selecting N=No in configuration setting 13 will disable economizer operation.



**Figure 3. Dry Bulb Sensor**

On a call for cooling from the wall-mounted thermostat, if outdoor conditions are suitable, the sensor will open the damper and admit outside air (i.e., economizer free cooling). If the outdoor ambient is too hot (dry bulb sensor only), the sensor will place the actuator in the closed or minimum open position and activate mechanical cooling. The compressor is locked-out during the economizer cooling mode. The Supply Air sensor monitors the supply air of the system in economizer mode to modulate the economizer damper to maintain a 55°F supply air temperature.

During the testing of the air conditioner at the factory, the control board has been configured for the sensor type used in the system. There should be no need to change the sensor configuration. If a dry bulb sensor is being used, setting 14 of the control board configuration menu will be set for DB=Dry Bulb. A disconnected or faulty dry bulb sensor is annunciated on the control board display as “db-F”. Economizer operation is only allowed in Cooling Mode.

*Note:* A call for Y2 Inputs or a faulty or disconnected dry bulb sensor will override the economizer operation and force the compressor to operate.

**3.3 Supply Air Sensor** – The supply air sensor is a 10K NTC sensor probe mounted on a bracket in the supply air opening of the system. The probe senses the air temperature entering the structure, and provides a signal to the economizer controller for modulating the position of the damper. The default supply air temperature is 55°F in economizer cooling and is not adjustable. A disconnected or faulty supply air sensor is annunciated on the control board display as “AS-F”.

*Note:* A faulty or disconnected supply air sensor will override the economizer operation and force the compressor to operate.

**3.4 Minimum Position** – The minimum position controls the amount of outside air introduced in the building when not in economizer operation or to meet a minimum outside air requirement to keep the damper open. This feature is only applicable to systems with economizer or ventilation damper options. The minimum position can be adjusted in the control board configuration menu with setting 16. The setpoint adjustments are from 20 (2vdc) to 100 (10vdc) in 1vdc increments. This is an independent adjustment and can be set to drive the ventilation damper open to any position from closed to fully opened. A selection of 20 (2vdc) is the same as being set to OFF or fully closed.

## **4.0 Heating Operation**

**4.1 Electric Heat (AC Systems with Electric Heat)** – When there is a request for “Electric Heat” (W2-signal via Digital input or Modbus), the system will run the Indoor Motor for 10 seconds

prior to energizing the Heater Output. The Indoor Motor will operate at the “W2” speed setting on the board or via Modbus. Once the Heater output is energized, the Heater comes on at full capacity (no staging). The Heater will remain on until the Heating setpoint is satisfied and the request is dropped. Once the heating setpoint is satisfied, the Indoor motor continues to run based on the fan purge timer setpoint (default 90 seconds) selected in setting 3 of the configuration menu of the control board.

**Note:** A request for Cooling and Heating at the same time is not allowed and control board will not allow the electric heat to operate.

**4.2 Heat Pump Heating Operation** – This section will describe the sequence of operation which takes place during Direct Expansion (DX) heating from a control standpoint. The reversing valve (O Input) must NOT be energized for Heating operation on Heat Pump systems.

**Note:** The system type must be configured for “HP” operation in setting 1 of the configuration menu of the control board for proper HP system operation. This system type is selected at the factory and there’s no need to change this setting.

In normal operating mode, a request for “Heat Pump Heating” Y1 signal via Digital input or Modbus), energizes the Compressor 1 and 2 Relay Output (CC1+CC2) on the PCB. The controller provides a continuous control signal associated to the Indoor Fan Motor, that is proportional to the “Y2” speed setting on the board or via Modbus. The system is defaulted to operate at Full capacity in heat pump heating mode. It also outputs a request for the Outdoor Fan to operate at the max speed. In heat pump Heating operation, the compressor operates at Full capacity and the indoor and outdoor fans remain on continuously. The outdoor fan does not modulate in heat pump heat mode.

**4.3 Defrost Operation (Heat Pump Systems Only)** – The board has an integral accumulation run timer that runs on every request for heat pump heating. The system has a Defrost Sensor (DS) that monitors the outdoor coil circuit for freezing conditions. If the defrost sensor registers a temperature of 32°F while in the heat pump heating mode, it will initiate a defrost cycle based on the time selected in the control board configuration menu setting 8. The defrost time intervals selections are 30, 60 and 90 minutes and the factory default setting is 30 minutes. If the defrost sensor is still calling for defrost at the end of this delay, it will de-energize the outdoor fan, energize the reversing valve through the RV terminal, and keep the compressor energized. The defrost cycle will terminate on time or temperature. It will have a maximum defrost run time of 10 minutes, however, if the defrost sensor registers a temperature of 70°F or higher before the 10-minute maximum run time, the defrost cycle will terminate. If the defrost cycle has not completed (DS sensor above 70°F) due the heating call being satisfied, the defrost cycle will continue upon the next call for heat pump heating to complete the defrost cycle. If freezing conditions are not present at the end of the defrost interval timer, the system will not perform a defrost cycle.

**Note:** If the DS sensor is disconnected or faulty, the compressor will not operate in heat pump heating mode and the control board display will annunciate the fault as “DS-F”.

**Note:** If “Yes” has been selected for Electric Heat During Defrost (EHDD) and “No” selected for the SCKT, the electric heat (EH) output will be energized during a defrost cycle to supply heat while the coil defrosts.

**4.4 Electric Heat / Outdoor Sensor / SCKT / EHDD (Heat Pumps) – Electric Heat (HP systems with electric heat)**– When there is a request for “Electric Heat” (W2-signal via Digital input or Modbus), the system will run the Indoor Motor for 10 seconds prior to energizing the Heater Output. The Indoor Motor will operate at the “W2” speed setting on the board or via Modbus.

Once the Heater output is energized, the Heater comes on at full capacity (no staging). The Heater will remain on until the Heating setpoint is satisfied and the request is dropped. Once the heating setpoint is satisfied, the Indoor motor continues to run based on the fan purge timer setpoint (default 90 seconds) selected in setting 3 of the configuration menu of the control board.

When the system is operating in Heat Pump mode the electric heat is considered as supplemental heat and will only be allowed under certain conditions due to additional features that may be used. These features include the Outdoor Sensor and SCKT (safety circuit). See ODS and SCKT for more details.

#### **ODS - Outdoor Sensor (Heat-Pumps Only)**

The outdoor sensor only responds to the temperature of the outside air. The sensor is a 10K NTC sensor probe. The factory setting is 30°F. This setpoint can be adjusted in 1°F increments from 30°F to 50°F in the control board configuration menu setting 12.

If the optional Outdoor Sensor is used (Heat-pump systems only). If the outdoor temperature is below the ODS setpoint, the Heat-pump heating will shut off and the Electric Heat will operate upon a call for heating.

*Note:* A request for Cooling and Electric Heat at the same time is not allowed and the control board will not allow the electric heat to operate.

#### **SCKT – Safety Circuit (Heat-Pumps Only)**

The SCKT is a selectable menu option in the control board configuration menu setting 10. The options for this feature are Y=Yes or N=No. When set to Y=Yes, control board will prevent the compressor and electric heat from operating simultaneously. In this case the compressor will shut off upon a request for “W2” (Electric Heat). The compressor will remain off as long as the request for W2 is active. Once the request for W2 satisfies the compressor will be allowed to operate. The default setting for SCKT is N=No, the electric heat and compressor will be allowed simultaneous operation in the heat pump heating mode.

#### **EHDD – Electric Heat During Defrost (Heat-Pumps Only)**

The EHDD is a selectable menu option in the control board configuration menu setting 9. The options for this feature are Y=Yes or N=No. When set to Y=Yes, control board will force the electric heat to operate during a defrost cycle unless SCKT is set to Y=Yes or the outdoor temperature is not below ODS (if equipped) setpoint. The default setting for EHDD is Y=Yes.

*Note:* SCKT takes priority over ODS and EHDD.

### **5.0 Dehumidification Operation AC / HP**

**5.1 Hot Gas Reheat (if equipped)** – When there is a request for “Dehumidification” (HUM-signal via Digital input or MODBUS), this will result in the control board energizing the Indoor Fan (IBR), Compressor 1 (CC1), Compressor 2 (CC2), Reversing Valve (RV) “heat pumps only” and the Reheat (RH) relay outputs on the board. This forces the system to operate in the full capacity cooling mode while energizing the reheat solenoid valve to allow hot gas to be introduced into the supply air stream of the system for dehumidification operation. The indoor fan motor will operate at the “Dehum” speed setting on the board or via MODBUS. The indoor fan remains on continuously but the outdoor fan modulates based on liquid line temperature. The Fan Cycle Control Sensor (Low Ambient Control Sensor) monitors the liquid line to maintain a 90°F liquid line temperature. When the liquid line temperature is below 80°F the outdoor fan will shut off. A liquid line temperature above 115°F will force the outdoor fan to operate at the maximum speed set on the control board for setting 8 in the configuration menu. The outdoor fan will speed up and slow down between liquid line temperature of 80°F and 115°F. Systems with (PSC Outdoor Motors) utilizes a Fan Cycle Switch which closes at 400 PSIG to energize the OFR (outdoor fan

relay) to start the outdoor fan which runs until the switch reopens (at 290 PSIG). These outputs function as described until the Dehumidification setpoint is satisfied. This is considered as ON/OFF fan cycle control and the PSC motor will not modulate.

**Note:** A request for Y1 or Y2 via digital input or MODBUS takes priority over dehumidification operation and the hot gas reheat valve will de-energize.

**5.2 Electric Reheat (if equipped)** – When there is a request for “Dehumidification” (HUM-signal via Digital input or MODBUS), this will result in the control board energizing the Indoor Fan (IBR), Compressor 1 (CC1), Compressor 2 (CC2), Reversing Valve (RV) “heat pumps only” and the Reheat (RH) relay outputs on the board. This forces the system to operate in the full capacity cooling mode while energizing the electric heat to allow heat to be introduced into the supply air stream of the system for dehumidification operation. The indoor fan motor will operate at the “Dehum” speed setting on the board or via MODBUS. The indoor fan remains on continuously but the outdoor fan modulates based on liquid line temperature. The Fan Cycle Control Sensor (Low Ambient Control Sensor) monitors the liquid line to maintain a 90°F liquid line temperature. When the liquid line temperature is below 80°F the outdoor fan will shut off. A liquid line temperature above 115°F will force the outdoor fan to operate at the maximum speed set on the control board for setting 8 in the configuration menu. The outdoor fan will speed up and slow down between liquid line temperature of 80°F and 115°F. Systems with (PSC Outdoor Motors) utilizes a Fan Cycle Switch which closes at 400 PSIG to energize the OFR (outdoor fan relay) to start the outdoor fan which runs until the switch reopens (at 290 PSIG). These outputs function as described until the Dehumidification setpoint is satisfied. This is considered as ON/OFF fan cycle control and the PSC motor will not modulate.

**Note:** A request for Y1 or Y2 via digital input or MODBUS takes priority over dehumidification operation and the electric heat will de-energize.

**5.3 Pulse Reheat / Dehum Supply Set** – The Pulse reheat feature allows for supply air temperature limiting dehumidification control. When setting 19 is set to Y in the configuration menu the RH output of the control board will energize and de-energized based on the dehumidification supply air temperature setpoint in setting 20 of the configuration menu. During dehumidification operation the RH output is energized and the supply air is monitored to allow the supply air to reach the dehumidification supply air setpoint. When the setpoint is reached, the RH output is de-energized and the system will operate in cooling mode until the supply air temperature drops 5°F. When the 5°F differential has been met the RH output will energize and dehumidification operation will resume. When setting 18 is set to N= No, Pulse Reheat is not active and the supply air will not be monitored to limit supply air temperature in the dehumidification mode. The Pulse Reheat and Dehum Supply Set may also be selected and adjusted via MODBUS.

## **6.0 Refrigeration Protection**

**6.1 High Pressure Lockout** – This condition describes the abnormal rise in Head Pressure within system with an acceptable limit of 660 PSI (+/-20PSI). The fault will only be active when the High-Pressure Switch (Normally Closed) opens during a request for Cooling or Heat Pump Heating. The first time this fault condition occurs, the system cuts the compressor off WITHOUT locking out. Once the pressure normalizes (drops below 450 PSI), the system will resume operation if the cooling or heat pump heating call still exist. If this fault occurs a second time on the same Cooling or Heat pump heating request, the system locks out. Lockouts can be monitored using the control board display for the current fault. The fault for a high-pressure lockout will displayed as “HP-Lc”. The faults can also be monitored via MODBUS by reading the respective value based on the MODBUS map that is provided. After this lockout condition is reached, the system must be power cycled to clear the fault. The system will continue to lockout until the problem is rectified.

**6.2 Low Pressure Lockout** – This condition describes the abnormal drop in Suction Pressure within system with an acceptable limit of 75 PSI (+/-20PSI). The fault will only be active when the Low-Pressure Switch (Normally Closed) opens during a request for Cooling. The first time this fault condition occurs, the system cuts the compressor off WITHOUT locking out. Once the pressure normalizes (rises above 105 PSI), the system will resume operation if the cooling call still exist. If this fault occurs a second time on the same Cooling request, the system locks out. Lockouts can be monitored using the control board display for the current fault. The fault for a high-pressure lockout will displayed as “*HP-Lc*”. The faults can also be monitored via MODBUS by reading the respective value based on the MODBUS map that is provided. After this lockout condition is reached, the system must be power cycled to clear the fault. For a 2-compressor system, each lockout is isolated to the respective circuit and will not interfere with the operation of the other circuit providing that the circuits operate independently. The system will continue to lockout until the problem is rectified.

*Note:* The Low-pressure switch is ignored in heat-pump and de-humidification operation. The loss of charge switch is monitored in all modes of compressor operation.

**6.3 Loss of Charge / Flat Unit** – This condition describes the abnormal drop in Suction Pressure within system with an acceptable limit of 40 PSI (+/-20PSI). The fault will only be active when the Loss of Charge Switch (Normally Closed) opens during compressor operation. The first time this fault condition occurs, the system cuts the compressor off WITHOUT locking out. Once the pressure normalizes (rises above 60 PSI), the system will resume operation if the cooling call still exist. If this fault occurs a second time on the same Cooling request, the system locks out. Lockouts can be monitored using the control board display for the current fault. The fault for a high-pressure lockout will displayed as “*HP-Lc*”. The faults can also be monitored via MODBUS by reading the respective value based on the MODBUS map that is provided. After this lockout condition is reached, the system must be power cycled to clear the fault. For a 2-compressor system, each lockout is isolated to the respective circuit and will not interfere with the operation of the other circuit providing that the circuits operate independently. The system will continue to lockout until the problem is rectified.

*Note:* Loss of Charge and Low-pressure switches are used on Heat Pump systems. Air-conditioning systems use the Low-pressure switch for both low-pressure and loss of charge faults.

**6.4 Freeze Sensor Protection** – A10K Nominal NTC Thermistor is connected to the “LPS 1 input with the sensor secured to the evaporator feeder tubes to monitor for freezing conditions while in cooling operation. The sensor is ignored for the first 15 minutes of compressor operation and after this time if the sensor reads 25°F or less the compressor will shut down. The control board will display an “FS” fault and compressor will remain off for a minimum of 3 minutes. The sensor must reach a temperature of 55°F in addition to the 3-minute minimum off timer. After the timer and reset temperature has been met the compressor is allowed to operate in normal operation.

*Note:* A freeze fault does not initiate a hard lockout condition. A freeze fault only interrupts the compressor cooling operation temporarily. The freeze sensor input is ignored if the sensor is not connected to the control board input.

**6.5 Anti-Short Cycle** – This is a built-in protection mechanism that increases the reliability of the compressor by protecting it from excessive short cycling. When the compressor goes off, due to any fault, emergency or if the cooling / heat pump heating setpoint is satisfied, a built-in 3-minute timer locks the compressor for that respective circuit out. This can be monitored and adjusted via MODBUS by referencing the appropriate register. However, it can only be monitored at the board level by waiting for the 3 minutes to elapse.

## **7.0 Additional Features**

**7.1 Modulating Head Pressure Control (ECM Outdoor Motors)**– A 10K Nominal NTC Thermistor is connected to the “FCC1” and “FCC2” inputs for circuit 1 and circuit 2 respectively. The sensor is secured to the liquid line of the system to monitor the liquid line temperature. When this sensor is connected, the thermistor value is used as the process variable when controlling the head pressure. The controller modulates the Outdoor Fan Motor to maintain a 90°F temperature setpoint. The controller will always use the greater value of FCC1 and FCC2 input as the reference point. In the event that the Thermistor is disconnected, the controller reverts to the outdoor fan operating at the max speed setting selected on the control board configuration menu setting 8.

*Note:* Systems with PSC outdoor motors utilize a fan cycle switch in the refrigeration circuit for on/off fan cycle head pressure control.

### **PSC Motor Head Pressure Control**

The onboard outdoor fan relay (OFR) is used to control the Fan Cycle Switch based on CC output to the Compressor. Once the compressor out (CC1) is energized the OFR output will also be energized and the fan cycle switch will cycle on and off at 290psi and 400psi. This will turn the Outdoor Fan Motor on and off to maintain the head-pressure of the system, the OFR output is only used on systems with PSC out door motor and Fan Cycle Switch (FCC) only.

**7.2 Emergency Ventilation (Motorized Damper or Economizer Equipped Systems)**– When there is a request for “Emergency Ventilation” (EV-signal via Digital input or Modbus), the system will run the Indoor Motor at the “Y2” speed setting on the board or via Modbus and provide a 10vdc signal from the ECO output of the control board to drive the motorized damper fully open.

*Note:* The compressor and electric heat WILL NOT operate while in the emergency ventilation mode.

**7.3 Y2/“Formerly Forced Cooling” (economizer equipped systems)**– During economizer cooling, if a request for “Y2” (Y2-signal via Digital input or MODBUS) is present. The control board will force the economizer to close and start the compressor to operate at full capacity cooling. This is considered an override of the economizer in the event economizer cooling can’t keep up with the cooling demand in economizer mode. The Indoor Motor at the “Y2” speed setting on the board or via MODBUS and the system will operate in normal cooling mode until the request for Y2 is satisfied. Once satisfied the system will be allowed to return to economizer operation if conditions are favorable.

**7.4 Low Voltage (Brownout)**– The control board monitors the 24 VAC power supply for low voltage protection. When the power supply voltage is 16 VAC or less for 10 seconds the control board will de-energize all outputs. This is considered a voltage brownout (low voltage) condition and the display of the control board will show “03” as an indicator of brownout (low voltage). When the voltage rises back to 17 VAC, the control board will allow the system to operate.

*Note:* The nominal power supply for the control board is 24VAC and this voltage should be confirmed during startup to assure normal operation.

## **8.0 Smoke / Fire Shutdown**

**8.1 System Shutdown Contact Wiring**– Add Normally Closed Dry contacts as shown for immediate shutdown of HVAC upon contacts opening.

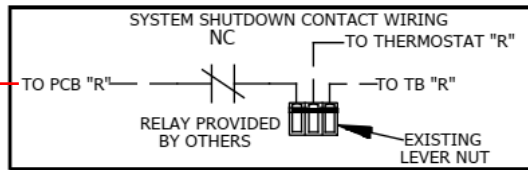
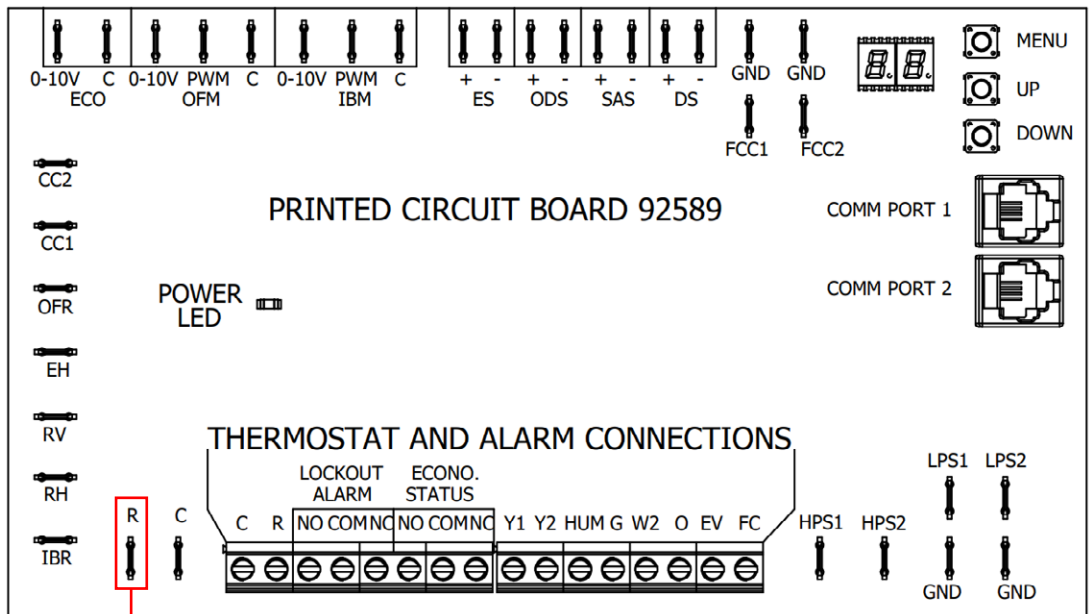

## 2.6 Mitigation Board Sequence of Operation

### Mode of Operation

At power up, the A2L control enters the configuration state, a 5-second window in which the control identifies active sensor ports. If there are no active sensor ports, the control enters the communication fault state. If a sensor is detected, the control enters the sensor warm-up state. Once the detected sensor reports Run mode, the control enters normal operation and constantly monitors the mode and %LFL status of the sensor. See the table below for all respective outputs for each state.

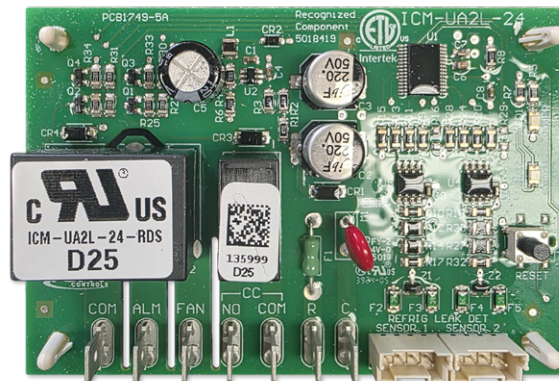

### A2L Mitigation Control Board

Once an active sensor port is established, it is required for all future operation, and cannot be substituted by connecting a sensor on the other port. Loss of communication with an active sensor will result in the communications fault state, which can only be cleared by resuming communication with a sensor on that specific port.

In the event that 2 sensors are not connected and reporting different modes / statuses, the following priority will take place: LFL Fault->Communications Fault-> Warm-up-> Run.

**Note:** During the Warm-up / Communication Fault / LFL Fault states, the main control board will indicate “EF” (Emergency Ventilation) on the display. While in the “EF” mode, the indoor blower will operate and the motorized damper (if equipped) will drive open 100%.

Current State	Outputs	State-Change Conditions	Next State
Configuration	<b>CC:</b> Off <b>Alarm:</b> Off <b>Fan:</b> On <b>Status LED:</b> Off	• At least 1 sensor port is active • No sensor ports are active	• Sensor Warm-Up • Communication Fault
Sensor Warm-up	<b>CC:</b> Off <b>Alarm:</b> On <b>Fan:</b> Off <b>Status LED:</b> On	• Sensor reports Run mode • Sensor reports Error mode	• Normal Operation • Communication Fault
Normal Operation	<b>CC:</b> On <b>Alarm:</b> On <b>Fan:</b> Off <b>Status LED:</b> Off	• %LFL ~ Trip point • Loss of sensor communication	• %LFL Fault • Communication Fault
Communication Fault	<b>CC:</b> Off <b>Alarm:</b> Off <b>Fan:</b> On <b>Status LED:</b> 2 Blinks	• Valid data on required sensor port(s) and lockout timer expired	• Sensor Warm-Up
%LFL Fault	<b>CC:</b> Off <b>Alarm:</b> Off <b>Fan:</b> On <b>Status LED:</b> 1 Blink	• %LFL < Recovery point and lockout timer expired • Reset button actuated*	• Normal Operation

\*Only required when the Reset Mode is set to "Manual".

**Note:** Anytime the Fan output is “On”, the system will operate in emergency ventilation mode.

#### Fault Code

Status LED	Mode
Off	Normal Operation
On	Sensor Warm-Up
1-Blink	LFL Fault
2-Blinks	Communication Fault

#### Pin Connections for Sensors

Pin	Mode	Wire Color
PIN 1	5V	Red
PIN 2	A+	White
PIN 3	B-	Green
PIN 4	GND*	Black

### Replacement Parts

A2L Mitigation Control Board .....	P/N 92591
A2L Sensor (Qty 2) .....	P/N 70987
Sensor Harness (Qty 2).....	P/N 03972

When mounted, the LED will be visible by reflection on the mounted surface.



#### Standard 6 pin

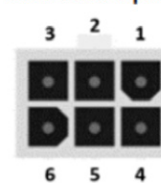

- 1 = Red Supply Voltage
- 2 = Black Earth / Ground
- 3 = White N.C. Output
- 4 = Blue Not Used
- 5 = Yellow Input Relay
- 6 = Orange - Not Used

#### A2L Leak Sensor Fault Codes

Operating Condition	LED Status Indicator
Power Up / Warm Up	Green Steady On
Normal Operation	Green Heartbeat
Power Up Fail	Amber Steady On
Near End of Life	Green and Amber Blinking
End of Life Replace Sensor	Red Blinking NOT Resettable
Internal Diagnostic Fail	Red Blinking Resettable
DTLV	Red Steady On
Out of Operating Range	Green and Amber Heartbeat

# Chapter 3 Installation



## WARNING

**Failure to observe and follow Warnings and Cautions and these Instructions could result in death, bodily injury or property damage. Read this manual and follow its instructions and adhere to all Cautions and Warnings in the manual and on the A/C unit.**

### 3.1 Equipment Inspection

#### Concealed Damage

Inspect all cartons and packages upon receipt for damage in transit. Remove cartons and check for concealed damage. **Important: keep the unit upright at all times.** Remove access panels and examine component parts. (Note: the "L"-shaped bottom bracket is screwed to the shipping pallet, against the air conditioner. Remove it before replacing the side screen). Inspect refrigerant circuit for fractures or breaks. The presence of refrigerant oil usually indicates a rupture. If damage is apparent, immediately file a claim with the freight carrier.

Units that have been turned on their sides or tops may have concealed damage to compressor motor mounts or to the oil system. If the unit is not upright, immediately file a claim for concealed damages and follow these steps:

1. Set unit upright and allow to stand for 24 hours with primary power turned on.
2. Attempt to start the compressor after 24 hours.
3. If the compressor will not start, makes excessive noise, or will not pump, return the unit to the freight carrier.

### 3.2 Pre Checks

Where electrical components are being changed, they shall be fit for the purpose and to the correct specification. At all times the manufacturer's maintenance and service guidelines shall be followed. If in doubt, consult the manufacturer's technical department for assistance.

The following checks shall be applied to installations using FLAMMABLE REFRIGERANTS:

1. The actual REFRIGERANT CHARGE is in accordance with the room size within which the refrigerant containing parts are installed.
2. The ventilation machinery and outlets are operating adequately and are not obstructed.
3. If an indirect refrigerating circuit is being used, the secondary circuit shall be checked for the presence of refrigerant.
4. Marking to the equipment continues to be visible and legible. Markings and signs that are illegible shall be corrected.
5. Refrigerating pipe or components are installed in a position where they are unlikely to be exposed to any substance which may corrode refrigerant containing components, unless the components are constructed of materials which are inherently resistant to being corroded or are suitably protected against being so corroded.
6. Check that cabling will not be subject to wear, corrosion, excessive pressure, vibration, sharp edges or any other adverse environmental effects. The check shall also take into account the effects of aging or continual vibration from sources such as compressors or fans.

### 3.3 Installation Requirements

#### General

1. Inspect unit for completeness. Check for missing parts (e.g. hardware). Refer to the installation kit information in section 2.3.

2. Remove access panels and check for loose wires. Tighten screw connections.
3. Complete and mail the warranty registration card.

You must consider all of the following when choosing the installation site:

1. **Noise.** Install the unit so that the least amount of noise will be transmitted to inhabited spaces.
2. **Condensate Drainage.** Condensate produced during operation must be discharged to a suitable drain.
3. **Placement.**
  - A) Place the unit in a shaded area, if possible.
  - B) Install it above ground for protection against flooding.
  - C) The unit exhausts air. Be sure that the airflow is not impeded by shrubbery or other obstructions.
  - D) When installing multiple units, please note the recommended clearances noted in Table 4.

4. **Airflow Requirements:**

Note the maximum static pressure. Keep duct lengths as short as possible. Do not obstruct airflow through the unit.

Duct work should be designed and installed in accordance with *all* applicable safety codes and standards. Marvair® strongly recommends referring to the current edition of the National Fire Protection Association Standards 90A and 90B *before* designing and installing duct work. The duct system must be engineered to insure sufficient air flow through the unit to prevent over-heating of the heater element. This includes proper supply duct sizing, sufficient quantity of supply registers, and adequate return and filter areas. Duct work must be of correct material and must be properly insulated. Duct work must be constructed of galvanized steel with a minimum thickness of .019 inches. Duct work must be firmly attached, secured, and sealed to prevent air leakage. See section 2.4 for additional duct work requirements.

5. **Clearances:**

Note the minimum clearances required for proper operation and service.

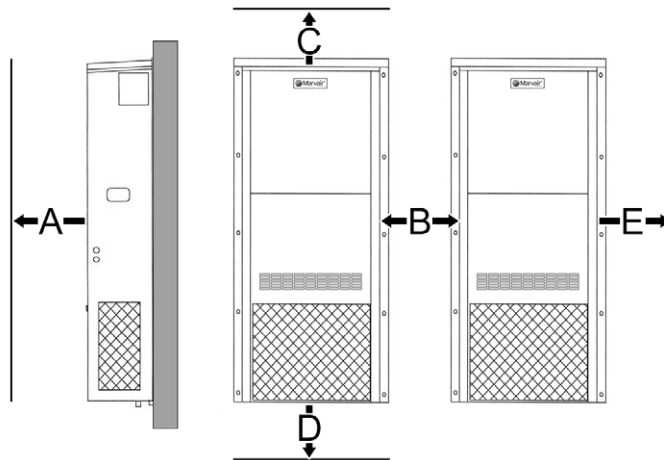

MODEL	MIN. CLEARANCE TO FRONT OF UNIT	MIN. CLEARANCE BETWEEN UNITS (TWO UNITS)	MIN. SPACE ABOVE UNIT	MIN. SPACE BELOW UNIT	MIN. CLEARANCE AROUND SIDES (SINGLE UNIT)
	A	B	C	D	E
1018A/1020A/1024A	30 inches (76 cm)	18 inches (46 cm)	24 inches (61 cm)	6 inches (15 cm)	30 inches (76 cm)
1030A/1036A	30 inches (76 cm)	18 inches (46 cm)	24 inches (61 cm)	6 inches (15 cm)	30 inches (76 cm)
1042A/1048A/1060A/2060A	30 inches (76 cm)	30 inches (76 cm)	24 inches (61 cm)	6 inches (15 cm)	30 inches (76 cm)
1072A/2072A	30 inches (76 cm)	30 inches (76 cm)	12 inches (31 cm)	6 inches (15 cm)	30 inches (76 cm)

**Table 8. Minimum Clearances**

6. **Codes:**

Make sure your installation conforms to all applicable electrical, plumbing, building, and municipal codes. Some codes may limit installation to single story structures.

7. **Electrical Supply:**

The power supply must have the appropriate voltage, phase, and ampacity for the model selected. Voltage must be maintained above minimum specified values listed below. Refer to the data sticker on the unit for ampacity requirements.

<b>Electrical Rating Designations*</b>	<b>A</b>	<b>C</b>	<b>D</b>	<b>Z</b>
Nominal Voltage	208/230	208/230	460	575
Phase	1	3	3	3
Minimum Voltage	197	197	414	518
Maximum Voltage	253	253	506	632

\* Letters refer to model number code designations. Refer to page 5.

**Table 9. Voltage Limitations**

**3.4 Installation Materials**

**Installation Kits**

Marvair air conditioners are shipped with one 12 Ga. "L" shaped bottom bracket. If you have not yet unpacked the unit, follow the instructions in section 2.1. All units have built-in full length mounting flanges. Therefore, use of mounting brackets is not required.

**Kit Components:**

1. One 12 Ga. "L"-shaped bottom bracket.

**Accessories:**

The package may include other factory-supplied items (optional) as follows on the next page:

**Controllers/Thermostats**

CommStat 10 Controller for Redundant HVAC Systems.....	P/N K/40167
CommStat 4 HVAC Controller, Solid State Lead/Lag Controller .....	P/N S/07846
Digital thermostat. 1 stage heat, 1 stage cool. 7 day programmable. Fan switch: Auto & On. Auto-change over. Keypad lockout. Non-volatile program memory. ....	P/N 50123
Digital thermostat. 2 stage heat, 2 stage cool. 7 day programmable. Fan switch: Auto & On. Auto-change over. Status LED's. Backlit display. Programmable fan. Non-volatile program memory. ....	P/N 50107

**Grilles/Wall Sleeves**

**Supply Grilles**

For MAH1018A - 17" x 5" (432 mm x 127 mm) .....	P/N 80682
For MAH1020A, MAH1024A, MAH1024A "B2" - 20" x 8" (508 mm x 203 mm).....	P/N 80674
For MAH1030A, MAH1030A "B2", MAH1036A, MAH1036A "B2" - 28" x 8" (711 mm x 203 mm).....	P/N 80675
For MAH1042A, MAH1048A MAH1060A - 30" x 10" (762 mm x 254 mm).....	P/N 80676
For MAH1060A, MGH1702A Reverse Flow - 30" x 16" (762 mm x 406 mm).....	P/N 93197
For MGH1072 - 30" x 10" (762 mm x 254 mm).....	P/N 80676

**Return Grilles**

For MAH1018A - 17" x 10" (432 mm x 254 mm) .....	P/N 93252
For MAH1018, MAH1020A, MAH1024A - 20" x 12" (508 mm x 305 mm) .....	P/N 80677
For MAH1024A "B2" – 22 <sup>1</sup> / <sub>8</sub> " x 14 <sup>1</sup> / <sub>8</sub> " (562 mm x 359 mm).....	P/N 80671
For MAH1030A, MAH1036A - 28" x 14" (711 mm x 356 mm).....	P/N 80678
For MAH1030A "B2", MAH1036A "B2" – 30 <sup>1</sup> / <sub>8</sub> " x 16 <sup>1</sup> / <sub>8</sub> " (765 mm x 410 mm).....	P/N 80672
For MAH1042A, MAH1048A, MAH1060A, MAH2072A - 30" x 16" (762 mm x 406 mm).....	P/N 80679
For MAH1060A, MGH1072A Reverse Flow - 30" x 10" (762 mm x 254 mm).....	P/N 93198
For MGH1072 - 30" x 16" (762 mm x 406 mm).....	P/N 80679

## Return Filter Grilles

Used when filter must be changed from the interior. Not recommended for economizer equipped air conditioners.

**Note:** Filter used in Return Filter Grille is 1" (25 mm) thick.

For MAH1020A, MAH1024A, MAH1024A "B2" - 20" x 12" (508 mm x 305 mm)..... P/N 80671

For MAH1030A, MAH1030A "B2", MAH1036A, MAH1036A "B2" -

28" x 14" (711 mm x 356 mm)..... P/N 80672

For MAH1042A, MAH1048A, MAH1060A, MAH2072A - 30" x 16" (762 mm x 406 mm) P/N 80673

### Additional Items Needed:

Additional hardware and miscellaneous supplies (not furnished by Marvair®) are needed for installation. For example, the list below contains approximate quantities of items typically needed for mounting a unit on a wood frame wall structure. Concrete or fiberglass structures have different requirements.

- (10) **3/8" carriage head mounting bolts** for unit mounting flanges. The length needed is typically the wall thickness plus one inch.
- (20) **3/8" washers**
- (10) **3/8" hex nuts**
- (6) **3/8" x 2-1/2" lag screws** for bottom bracket
  - **Silicone Sealer** to seal around cracks and openings
  - **Minimum 5 conductor low voltage multicolored wire cable** (i.e. thermostat wire)
  - **Appropriate electrical supplies** such as **conduit, electrical boxes, fittings, wire connectors**, etc.
  - **High voltage wire**, sized to handle the MCA (minimum circuit ampacity) listed on the data plate.
  - **Over-Current Protection Device** sized in accordance with the MFS (maximum fuse size) listed on the unit data plate.

### **WARNING - FIRE HAZARD**

**Improper adjustment, alteration, service, maintenance or installation could cause serious injury, death and/or property damage.**

**Installation or repairs made by unqualified persons could result in hazards to you and others. Installation MUST conform with local codes or, in the absence of local codes, with codes of all governmental authorities have jurisdiction.**

**The information contained in this manual is intended for use by a qualified service agency that is experienced in such work, is familiar with all precautions and safety procedures required in such work, and is equipped with the proper tools and test instruments.**

## 3.5 Porting and Duct Work

### General Information

Note: The following instructions are for general guidance only. Due to the wide variety of installation possibilities, specific instructions will not be given. When in doubt, follow standard and accepted installation practices, or contact Technical Support for additional assistance.

### Wall Openings (All MAH/MGH air conditioners)

Measure the dimensions of the supply and return ports on the unit.

Cut the openings in the exterior wall for the supply and return. **IMPORTANT: All units with electric heat must have 1" (25.4mm) clearance on all four sides of the supply outlet duct flange on the unit. The 1" (25.4mm) clearance must extend on all sides of the supply duct for the first 3 feet (1 meter) from the unit.**

**IMPORTANT: Marvair® requires a minimum of 1" (25.4mm)** from the surface of any supply ducts to combustible material for the first 3 feet (1 meter) of the duct.

For all air conditioners with electric heat, the wall sleeve **MUST** have 1" (25.4 mm) clearance around all four sides of the opening. Attach the perimeter flange of the wall sleeve to the framed opening with appropriately sized screws. Since electric heat can be added after the unit has been installed, Marvair recommends that all installations have the 1" (25.4 mm) clearance around the wall sleeve.

When installing the wall sleeve, the supply opening must be on top. The supply opening is smaller than the return air opening.

### **Ducting**

Extensions should be cut flush with the inside wall for applications without duct work.

Applications using duct work should be designed and installed in accordance with *all* applicable safety codes and standards. Marvair® strongly recommends referring to the current edition of the National Fire Protection Association Standards 90A and 90B *before* designing and installing duct work. The duct system must be engineered to insure sufficient air flow through the unit to prevent over-heating of the heater element. This includes proper supply duct sizing, sufficient quantity of supply registers, adequate return and filter area. Ductwork must be of correct material and must be properly insulated. Duct work must be constructed of galvanized steel with a minimum thickness of .019 inches for the first 3 feet (1 meter). Ductwork must be firmly attached, secured and sealed to prevent air leakage. Do not use duct liner on inside of supply duct within 4 feet (122cm) of the unit.

Galvanized metal duct extensions should be used to simplify connections to duct work and grilles. Use fabric boots to prevent the transmission of vibration through the duct system. The fabric must be U.L. rated to a minimum of 197°F (92°C).

Auxiliary devices which may be a POTENTIAL IGNITION SOURCE shall not be installed in the duct work. Examples of such POTENTIAL IGNITION SOURCES are hot surfaces with a temperature exceeding 1,292°F (700°C) and electric switching devices.

### **Minimum Airflow Requirements**

The duct system must be engineered to assure sufficient air flow through the unit even under adverse conditions such as dirty filters, etc. Use **Table 9** below and **Table 1, CFM at External Static Pressure (Wet Coil)** in section 1.4.

BASIC MODEL	MAXIMUM STATIC
MAH1018A/1020A/1024A	.50
MAH1030A/1036A	.50
MAH1042A/1048A/1060A/2060A/2072A	.50
MGH1072A	.50

**Table 10. Maximum Static Pressure (For units with 2" Pleated Filters)**

### **3.6 Fresh Air Hood (non-economizer air conditioners only)**

The fresh air hood is located on the inside, behind the slots on the bottom front panel. To access the hood, remove the screws that hold the front panel. The air flow can be adjusted from no (0%) fresh air to approximately 15% of rated air flow of fresh air, in 5% increments. The hood is shipped from the factory in the closed position (no fresh air). To provide fresh air, remove the two screws on either side of the hood and reposition as desired.

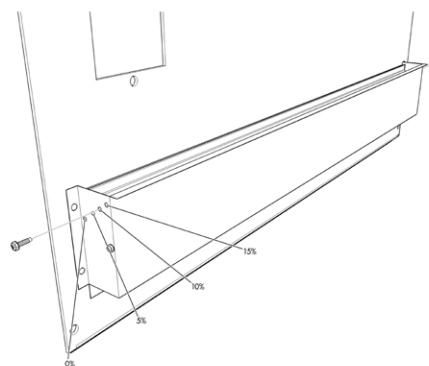

**Figure 4. Fresh Air Hood Damper, MAH1024A-MAH1072A**

### 3.7 Bracket Installation

1. All models have built-in mounting flanges.
2. Apply a bead of silicone sealer on the wall side of the bottom support brackets on the unit. Circle the mounting holes with the silicone bead.
3. Refer to Figure 4. Attach the bottom support bracket to the wall using appropriate 3/8" diameter hardware.

For example, on wooden structures, use 3/8" x 2-1/2" all-thread lag screws. The screws must penetrate the center of the wall stud. Drill a pilot hole in the stud to prevent it from splitting.

### 3.8 Mounting The Unit

1. For wiring into the back of unit, locate the lower of the two knockouts on the wall side of the unit. Drill a one inch hole in the shelter wall to match this opening. Allow sufficient clearance to run 3/4" conduit through the hole and to the unit.
2. Using an appropriate and safe lifting device, set the unit on the bottom support bracket mounted on the wall. You must stabilize the unit on the bracket with the lifting device or by some other means - the bracket alone is not sufficient.
3. Make sure that the duct flanges are properly aligned with the wall opening. Adjust as necessary.
4. Note the holes in each side flange. Using the holes for guides, drill holes through the wall with a 3/8" drill bit. Insert the 3/8" x 5" bolts through the flanges. Install nuts and washers on the inside of the shelter. Tighten the bolts to secure the unit.
5. Apply a bead of silicone where the mounting flange contacts the unit and the shelter wall.
6. On the inside of the shelter, install the wall sleeves in the supply and return air openings. The sleeves may be trimmed to fit flush with the inside wall.
7. Check the fit of each sleeve to its mating flange for possible air leaks. Apply silicone sealer to close any gaps. Install the air return and supply grilles.

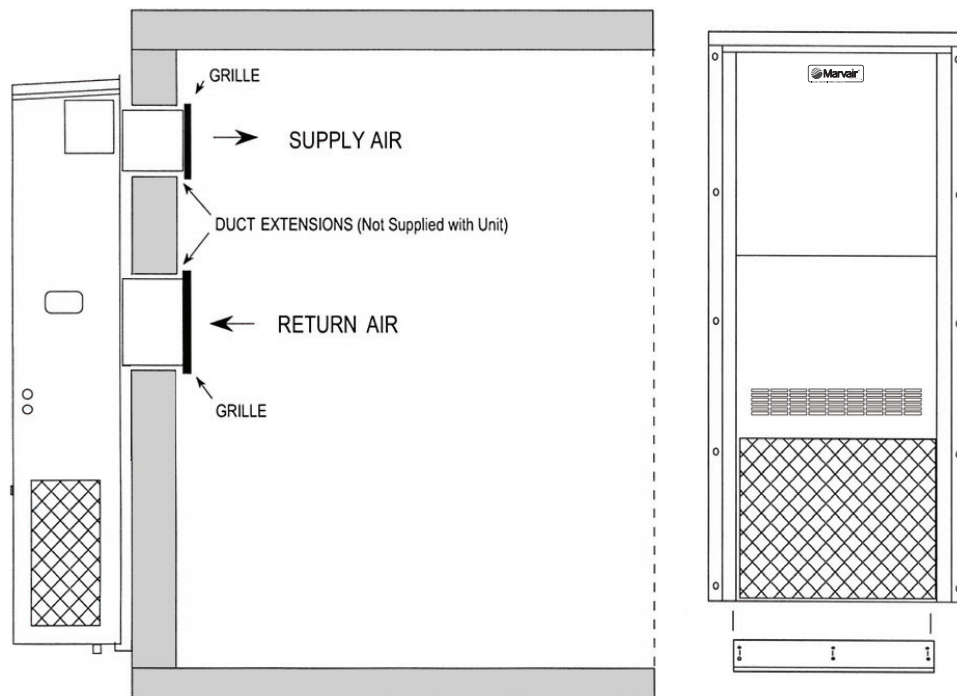

For units with electric heat, a one inch clearance is required around the duct extensions. The duct extensions must be constructed of galvanized steel with a minimum thickness of .019" as per the NFPA standards 90A & 90B.

**Figure 5. Marvair A/C Wall Mount Detail**

### 3.9 Electrical Connections



**WARNING**

#### **ELECTRICAL SHOCK HAZARD**

**Failure to follow safety warnings exactly could result in serious injury, death, and/or property damage.**

**Turn off electrical power at fuse box or service panel BEFORE making any electrical connections and ensure a proper ground connection is made before connecting line voltage.**



**CAUTION**

**NOTICE TO INSTALLER/CONTRACTORS: This unit's internal control circuit/transformer is designed to power factory installed unit components only. Connecting external component loads may be done at your own risk of voiding the manufacturer's product warranty.**

#### **Important**

All electrical work must meet the requirements of local codes and ordinances. Work should be done **only** by qualified persons.

Units may incorporate an internal crankcase heater for compressor protection. **The crankcase heater must be energized for at least 24 hours prior to starting the compressor.**

Scroll compressors, like several other types of compressors, will only compress in one rotational direction. The direction of rotation is not an issue with single-phase compressors since they will always start and run in the proper direction. However, three phase compressors will rotate in either direction depending upon phasing of power. Since there is a 50-50 chance of connecting power in such a way as to cause rotation in the reverse direction, it is imperative to confirm that the compressor is rotating in the proper direction at the initial field start-up of the system. Verification of proper rotation is made by observing that the suction pressure drops and the discharge pressure rises when the compressor is energized. An alternate method of verification for self contained system with small critical refrigerant charges, where the installation of gauges may be objectionable, can be made by monitoring the temperature of the refrigerant lines at the compressor. The temperature should rise on the discharge line while the suction line temperature decreases. Reverse rotation also results in a substantially reduced current draw when compared to tabulated values.

There is no negative impact on durability caused by operating three phase compressors in the reversed direction for a short duration of time, usually defined as less than one hour. However, after several minutes of operation the compressor's internal protector will trip. The compressor will then cycle on the protector until the phasing is corrected. Reverse operation for longer than one hour may have a negative impact on the bearings.

To change the rotation, turn off power to the unit and reverse L1 & L2 at the disconnect in the air conditioner.

#### **High Voltage Wiring - (Single Units)**

The power supply should have the proper voltage, phase, and ampacity for the selected model.

1. Refer to the electrical data on the data sticker on the unit for field wiring requirements of the unit. Size the incoming power supply lines and the fuse(s) or HACR breaker(s) according to requirements described in the National Electric Code. Run the power conductors through the knockouts on the side or back of the unit. Use appropriate conduit and strain reliefs.

## CAUTION

**Note: Power supply service must be within allowable range (+10% - 5%) of rated voltage stamped on the unit rating plate. To operate nominal 230/208V unit at 208V, change the transformer line tap from 240V to 208V following the instruction on wiring label in unit.**

2. Connect the wires to the input side of the internal breaker or terminal block (L1 & L2 for single-phase units; L1, L2, & L3 for three-phase models).
3. Install the ground wire on the ground lug.
4. For units designed for operation on 208/230V, 60Hz power supply, the transformer is factory wired for a 230V power supply. For a 208V power supply, remove the orange lead from the transformer and connect the red lead. Insulate the orange lead.
5. 460V units have a step down transformer for 230V motors.

## CAUTION

**The external breaker(s) that provide power to the air conditioner must be sized per the maximum Fuse Size (MFS) shown on the Unit's data label.**

### Dual Unit Phasing

For applications where one controller operates two units, e.g., the CommStat 4 or CommStat Touch HVAC controller.

Newer HVAC controllers such as the CommStat do not require unit phasing. However, if other devices are connected to the control system, phasing of the air conditioner is required. Earlier models; i.e., LL357, LL357A, LL357D2 require the unit to be properly phased.

1. Wire each unit as described in steps 1 through 4 above.
2. Test for proper phasing as follows:
  - A. Power up the units.
  - B. Using an AC volt meter set to the 300 volt scale, measure voltage between terminal L1 on the compressor contactor of unit #1 and terminal L1 on the compressor contactor of unit #2. If voltage is present, units are wired out of phase and must be rewired.
  - C. If units are not in phase, turn off power and reverse the field power leads connected to the internal circuit breaker on one of the units only.
  - D. Restore power and retest the phase (step B). When the voltage reads "0", the units are in phase.
  - E. Turn off power and proceed.

### Low Voltage Wiring

**IMPORTANT.** The following instructions are generic wiring instructions and may not be applicable for air conditioners with various options. Always refer to the wiring diagram in the air conditioner for the proper method to wire your unit.

1. On single units, pull the low voltage wiring (e.g., 18 gauge 4-conductor Class 2 thermostat wire) from the unit into the thermostat / subbase assembly. See Figure 13b for connections to various thermostats.
2. Mount the thermostat on the wall of the shelter. The thermostat should be located so that the supply air from the unit does NOT blow directly on to the thermostat. Connect the thermostat to the terminal block in the air conditioner as shown in Figure 13b.
3. On dual units, refer to the *CommStat 4 HVAC Controller Specification sheet*. Level and install the controller subbase. Wire the two A/C units to the Lead/Lag Controller, according to the wiring diagram on the specification sheet and as shown in Figure 6c for the CommStat 4 (note: the diagram also appears on the back cover of the controller).

*Remote Signalling:* Terminals 5 & 7(N.O.) and 6 & 7 (N.C.) on the terminal board are dry contacts which can be used for remote signalling in the event of a/c cutoff on low or high pressure limit.

*Continuous fan operation:* For continuous indoor fan operation on single units, install a jumper between terminals 8 and 3. For continuous indoor fan operation on dual units using the older LL357D4, install jumper between 8 and 3 and remove jumper between 1 and 3.

**CommStat 4 Lead /Lag Controller**

Please refer to the Product Data sheet for the Commstat 4 controller for complete instructions on installing and programming this controller.

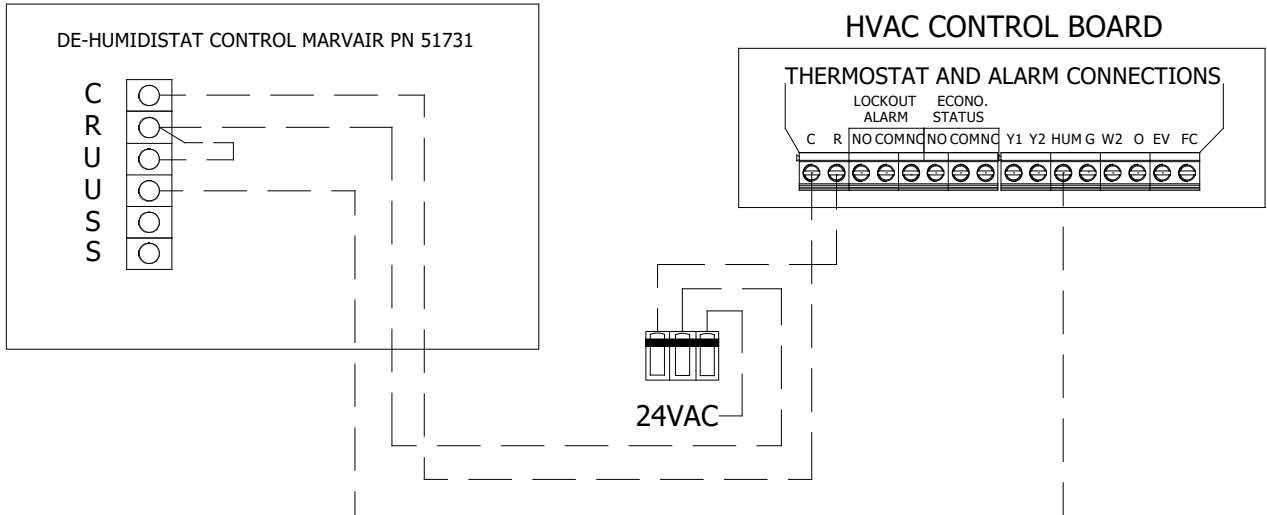

**Figure 6a. Humidistat Wiring to a Marvair Air Conditioner with Reheat.**

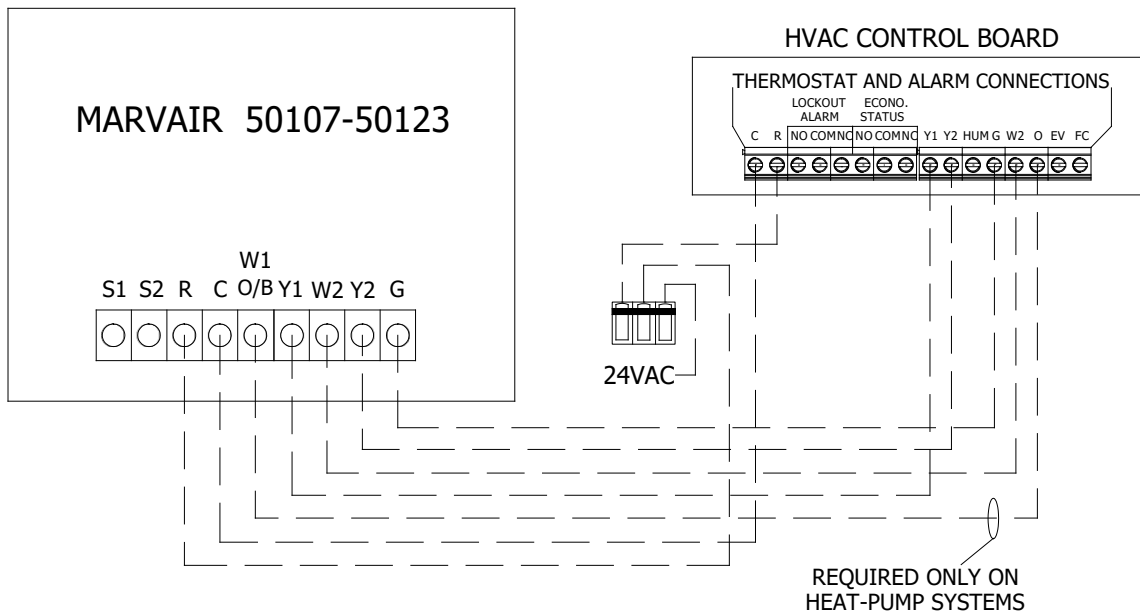

**Figure 6b. Thermostat Connection Diagram**

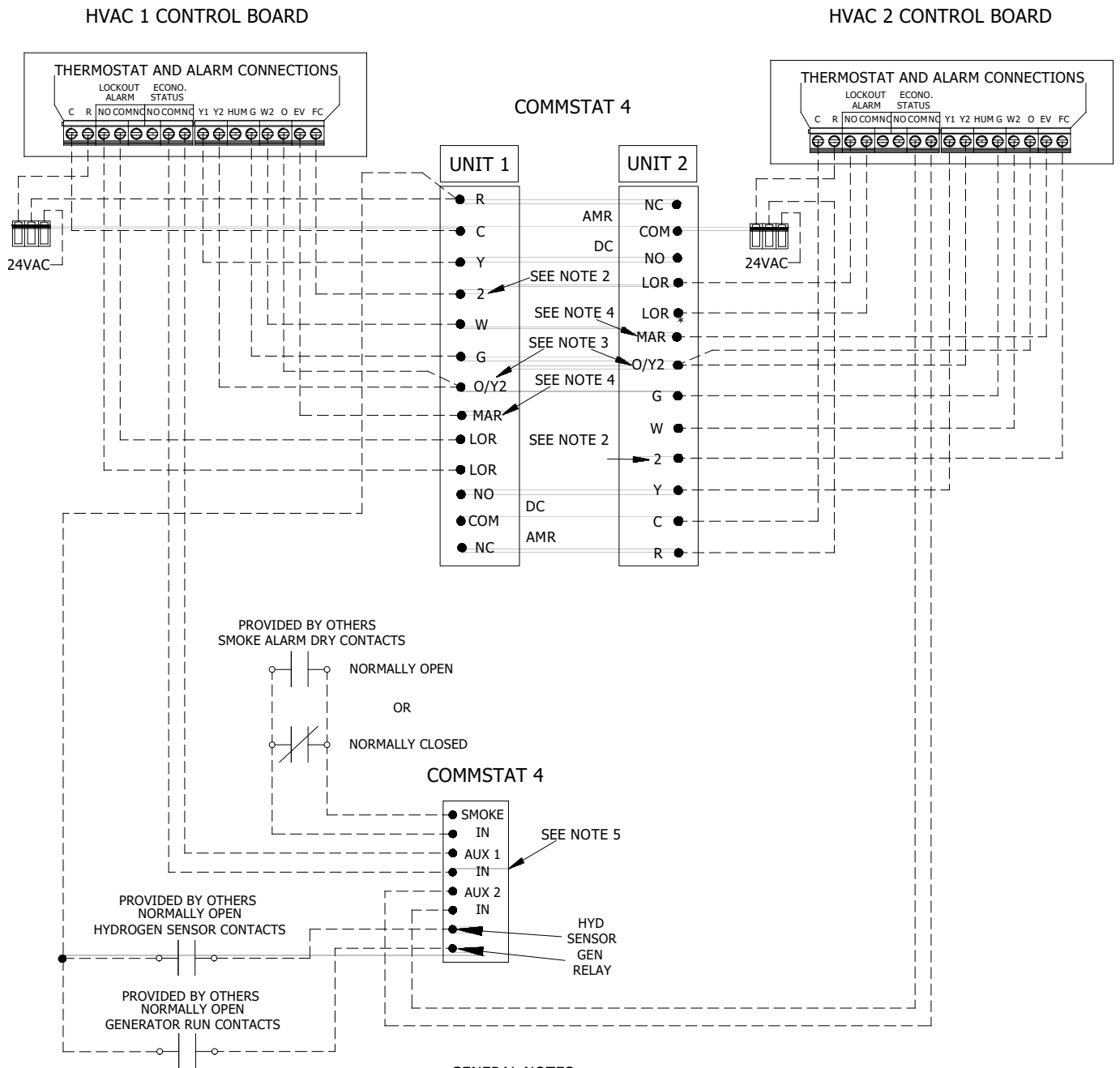

- GENERAL NOTES**
1. For immediate shutdown of HVAC upon a smoke fault, change setting 3 (Fan Purge) on the HVAC control board to N = No.
  2. The CommStat 4 terminal "2" is used to force mechanical cooling if the economizer cooling can't maintain the required cooling demand. This output is only used on systems equipped with economizers.
  3. The CommStat 4 terminal "O/Y2" is only used on systems with 2 stage compressors (Y2) or Heat Pumps systems (O).
  4. The CommStat 4 terminal "MAR" is only used on systems with economizers. The MAR output forces the system into emergency ventilation mode upon a hydrogen fault.
  5. The CommStat 4 "AUX 1" and "AUX 2" terminals are used for economizer status monitoring from the connected HVAC. This feedback is required for the CommStat 4 to override economizer cooling if the economizer and force mechanical cooling if the economizer can't maintain the required cooling demand. These inputs are only used with economizer equipped systems.

**Figure 6c. CommStat 4 Wiring Diagram**

# Chapter 4 Start-Up

## 4.1 Check-Out of Cooling Cycle

**Important:** Be sure that the crankcase heater (if used) has been energized for at least 24 hours before starting the unit(s). Double-check all electrical connections before applying power. Marvair air conditioners with scroll compressors running on 3Ø power must be checked for proper rotation during the initial start-up. Please refer to Section 2.8 for determining if the 3Ø compressors are rotating correctly. Incorrect rotation can damage the compressor and is not covered by the warranty

**Procedure:**

1. Set the cooling set point temperature on the wall thermostat to a point *higher* than the ambient temperature. Set the heating set point temperature to a temperature that is *lower* than the ambient.
2. Set the thermostat system switch in the AUTO position. Nothing should operate at this time.
3. Set the time delay in the electrical control box to three minutes. Check the changeover setting of the enthalpy or dry bulb sensor and reset it if needed (economizer-equipped models only). See Section 1.6.
4. Slowly lower the thermostat's cooling set point temperature until the switch closes. The indoor fan should operate.

Once the indoor fan turns on, allow approximately three minutes for the compressor to start. Note that the outdoor fan may not come on immediately, because it is cycled by refrigerant pressures.

NOTE: (Economizer-Equipped models only) To check the system operation under different ambient conditions, the air temperature and enthalpy sensors must be "tricked". When outdoor ambient conditions are higher than the control setting, a component cooler aerosol may be sprayed directly into the enthalpy sensor to simulate low enthalpy conditions, causing the economizer damper to open.

Alternately, when outdoor conditions are lower than the set point, a source of heat such as a hair dryer can be directed on the air temperature sensor to simulate warmer conditions, which will bring on mechanical cooling and start the compressor.

5. To stop cooling, slowly raise the thermostat cooling set point to a temperature higher than the ambient.

If the unit fails to operate, refer to the troubleshooting information in Chapter 4.

Follow the same procedure for additional units.

NOTE: The fan purge allows the indoor fan to run for approximately 90 seconds after the compressor is off. This operation provides a small improvement in system rated efficiency.

## 4.2 Check-Out of Heating Cycle

**Procedure:** (Applies only to units with resistance elements)

1. Raise the heating set point temperature to a setting which is higher than the ambient temperature. The fan and electric heat should immediately cycle on.
2. Move the system switch to the "OFF" position. All functions should stop.

NOTE: (Economizer Equipped models only) The damper blade should remain closed during the heating cycle (unless the minimum position potentiometer has been set for constant ventilation A fully counterclockwise position corresponds to full closure of the damper.

# Chapter 5 Troubleshooting

## 5.1 Overview

A comprehensive understanding of the operation of the air conditioner is a prerequisite to troubleshooting. Please read the Chapter 1 for basic information about the unit.

Marvair air conditioners are thoroughly tested before they are shipped from the factory. Although unlikely, it is possible that a defect may escape undetected, or damage may have occurred during transportation. However, the great majority of problems result from installation errors.

If you experience difficulties with your unit, please review the installation steps in Chapter 2.

Much time can be saved by taking a thoughtful and orderly approach to troubleshooting. Start with a visual check - are there loose wires, crimped tubing, missing parts, etc? Begin deeper analysis only after making this initial inspection.

The troubleshooting information in this manual is basic. The troubleshooting section contains problem/solution charts for general problems, followed by a compressor section.

Not every problem can be anticipated. If you discover a problem that is not covered in this manual, we would be very grateful if you would bring it to the attention of our service department for incorporation in future revisions.

As always, please exercise caution and good judgement when servicing the unit. Use only safe and proven service techniques. Use refrigeration goggles when servicing the refrigeration circuit.

### **WARNING**

**The refrigerant circuit has hot surfaces, and the electrical voltages inside of the unit may be hazardous or lethal. SERVICE MAY BE PERFORMED ONLY BY QUALIFIED AND EXPERIENCED PERSONS.**

## 5.2 Failure Symptoms Guide

PROBLEM/SYMPTOM	LIKELY CAUSE(S)	CORRECTION
<p>A. Unit does not run.</p> <p><b>NOTE:</b> An internal anti-short-cycle timer will prevent the unit from starting for .2 to 8 minutes following start-up.</p>	<ol style="list-style-type: none"> <li>1. Power supply problem.</li> <li>2. Tripped internal disconnect.</li> <li>3. Shut off by external thermostat or thermostat is defective.</li> <li>4. Unit off on high or low pressure limit.</li> <li>5. Internal component or connection failure.</li> </ol>	<ol style="list-style-type: none"> <li>1. Check power supply for adequate phase and voltage. Check wiring to unit and external breakers or fuses.</li> <li>2. Check internal circuit protection devices for continuity.</li> <li>3. Check operation of wall-mounted thermostat.</li> <li>4. Reset pressure switch.</li> <li>5. Check for loose wiring. Check components for failure.</li> </ol>
<p>B. Unit runs for long periods or continuously; cooling is insufficient.</p>	<ol style="list-style-type: none"> <li>1. Dirty filter or reduced airflow</li> <li>2. Low refrigerant.</li> <li>3. Component failure.</li> <li>4. Unit undersized for job.</li> </ol>	<ol style="list-style-type: none"> <li>1. Check air filter(s). Check blower operation. Remove airflow restriction.</li> <li>2. Check for proper charge and possible refrigerant leak.</li> <li>3. Check internal components, especially compressor for proper operation.</li> <li>4. Add additional units for greater capacity.</li> </ol>
<p>C. Unit cycles on high/low pressure limit.</p>	<ol style="list-style-type: none"> <li>1. Loss or restriction of airflow.</li> <li>2. Restriction in refrigerant circuit.</li> <li>3. Refrigerant overcharge (following field service)</li> <li>4. Defective pressure control.</li> </ol>	<ol style="list-style-type: none"> <li>1. Check blower assembly for proper operation. Look for airflow restrictions, e.g., the air filter. Check blower motor and condenser fan.</li> <li>2. Check for blockage or restriction, especially filter drier and capillary tube assembly.</li> <li>3. Evacuate and recharge to factory specifications.</li> <li>4. Check limit cutout pressures. Control is set to actuate at approximately 60 PSIG (low pressure) and 650 PSIG (high pressure)</li> </ol>
<p>D. Unit blows fuses or trips circuit breaker.</p>	<ol style="list-style-type: none"> <li>1. Inadequate circuit ampacity.</li> <li>2. Short, loose, or improper connection in field wiring.</li> <li>3. Internal short circuit. Loose or improper connection(s) in unit.</li> <li>4. Excessively high or low supply voltage or phase loss (3Ø only)</li> </ol>	<ol style="list-style-type: none"> <li>1. Note electrical requirements in Chapter 2 and correct as necessary.</li> <li>2. Check field wiring for errors.</li> <li>3. Check wiring in unit. See wiring and schematic diagrams. Test components (especially the compressor) for shorts.</li> <li>4. Note voltage range limitations specific to the compressor troubleshooting section.</li> </ol>
<p>E. Water on floor near unit.</p>	<ol style="list-style-type: none"> <li>1. Obstruction in condensate line.</li> <li>2. Obstruction or leak in condensate pan.</li> <li>3. Unit is not level.</li> </ol>	<ol style="list-style-type: none"> <li>1. Check for clog or restriction.</li> <li>2. Check pan for leak or blockage.</li> <li>3. Level unit.</li> </ol>
<p>F. No space heating or reduced heating (units equipped with resistance elements)</p>	<ol style="list-style-type: none"> <li>1. Defective heating element(s).</li> <li>2. Thermal limit open.</li> <li>3. Defective heater contactor.</li> </ol>	<ol style="list-style-type: none"> <li>1. Check resistance element(s) for continuity.</li> <li>2. Check continuity across thermal limit switch.</li> <li>3. Check relay for proper operation. Replace if defective.</li> </ol>

## 5.3 Compressor Troubleshooting

NOTE: It is important to rule out other component failures before condemning the compressor.

The following electrical tests will aid diagnosis:

1. **Start-Up Voltage:** Measure the voltage at the compressor contactor during start-up. The voltage must exceed the minimum shown in Table 5, section 2.2, or compressor failure is likely. A low voltage condition must be corrected.
2. **Running Amperage:** Connect a clip-on type ammeter to the (common) lead to the compressor. Turn on the supply voltage and energize the unit. The compressor will initially draw high amperage; it should soon drop to the RLA value or less. If the amperage stays high, check the motor winding resistances.  
**NOTE:** Feel the top of the compressor to see if it has overheated. If it is hot, the internal overload may be open. You may have to wait several hours for it to reset.
3. **Motor Winding Resistances:** Using a digital volt-ohm meter (VOM), measure the resistance across the compressor windings as shown below.

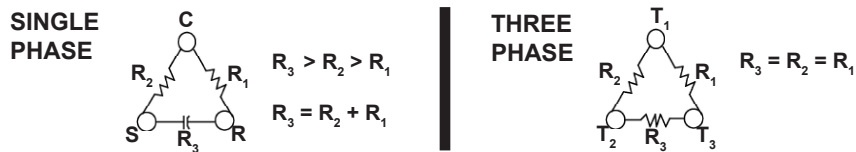

Resistance can be measured as shown above. Any deviation from above values could indicate a defective compressor.

4. **High Voltage/Insulation Test:** Test internal leakage with a megohmmeter. Attach one lead to the compressor case on a bare metal tube and to each compressor terminal to test the motor windings. A short circuit at high voltages indicates a motor defect. Do not do this test under vacuum.
5. On single phase models, check the capacitor by substitution.

## 5.4 Control Board Diagnosis

The PCB is equipped with an on board seven-segment display (see Section 2.3) for configuring various settings and displaying faults. During normal operation the display remains off unless the configuration menu is accessed or a fault has occurred. Faults will be annunciated on the display as shown below:



Display	Displayed Faults
<b>A2L</b>	A2L Sensor Fault / Disconnected Sensor
<b>AS-F</b>	Supply Air Sensor Fault (sensor disconnected or faulty) if equipped
<b>DB-F</b>	Dry Bulb / Outdoor Sensor Fault (sensor disconnected or faulty) if equipped
<b>DS-F</b>	Defrost Sensor Fault (sensor disconnected or faulty) Heat Pumps Only
<b>ES-F</b>	Enthalpy Sensor Fault (sensor disconnected or faulty) if equipped
<b>EF</b>	Emergency Fan / Ventilation Active
<b>FS</b>	Freeze Sensor Fault
<b>LP-1F</b>	Low Pressure Lockout
<b>HP-Lc</b>	High Pressure / Loss of Charge Lockout
<b>o3</b>	Low Voltage "Brownout" 16vac or less for 10 minutes

## 5.5 Control Board Diagnosis (Alternate Construction)

The control board (see section 1.6a for a complete description of the control board) has a red diagnostic LED which indicates the lockout fault. The control board will enter into and indicate lockout if either of the fault conditions (LPS or HPS) occur twice.

The contactor must be closed before the first fault condition can be recognized by the control board. The contactor will be closed 3 minutes after the unit is energized and only if cooling is required. The first fault condition will open the contactor and shutdown the unit. The contactor on the unit that has the fault condition must be closed before the second fault condition can be recognized by the control board. The contactor on the unit with the fault condition will close after 3 minutes if the unit is still calling for cooling and if the fault condition no longer exists. If you get a second fault condition, the contactor will open and shutdown the unit. The “red” led will have one blink if the high pressure switch has opened twice and will have two blinks if the low pressure switch has opened twice. The unit must be in the cooling mode (compressor contactor Closed) before a fault condition can occur.

# Chapter 6 Maintenance

## 6.1 Scheduled Maintenance

Repair and maintenance to electrical components shall include initial safety checks and component inspection procedures. If a fault exists that could compromise safety, then no electrical supply shall be connected to the circuit until it is satisfactorily dealt with. If the fault cannot be corrected immediately but it is necessary to continue operation, an adequate temporary solution shall be used. This shall be reported to the owner of the equipment so all parties are advised. Initial safety checks shall include:

- That capacitors are discharged: this shall be done in a safe manner to avoid possibility of sparking
- That no live electrical components and wiring are exposed while charging, recovering or purging the system
- That there is continuity of earth bonding
- Sealed electrical components shall be replaced
- Intrinsically safe components must be replaced

Marvair strongly recommends that the air conditioner be serviced a minimum of twice a year – once prior to the heating season and once prior to the cooling season. At this time the filters, evaporator coil, condenser coil, the cabinet, and condensate drains should be serviced as described below. Also at this time, the air conditioner should be operated in the cooling and heating cycles as described in Chapter 3, Start-Up. In addition to this seasonal check-out, the AC unit should be maintained as follows:

### Air Filter

Replace the air filter whenever it is visibly dirty. Never operate the unit without the filter in place.

### Evaporator

If the evaporator becomes clogged or dirty, it may be cleaned by careful vacuuming or with a commercial evaporator cleaning spray. DO NOT use a solvent containing bleach, acetone, or flammable substances. Turn off power before cleaning. Be careful not to wet any of the electrical components. Be sure the unit has dried before restarting.

### Condenser

Periodically inspect the outdoor condenser coil and the cabinet air reliefs for dirt or obstructions. Remove foreign objects such as leaves, paper, etc.

If the condenser coil is dirty, it may be washed off with a commercial solvent intended for this purpose. TURN OFF POWER BEFORE CLEANING! Be sure that all electrical components are thoroughly dry before restoring power. Use a fin comb of the correct spacing to straighten mashed or bent fins.

### Cabinet

The cabinet may be cleaned with a sponge and warm, soapy water or a mild detergent. Do not use bleach, abrasive chemicals or harmful solvents.

### Drains

Regularly check the condensate drain. If a commercial drain solvent is used, flush out the drain pan and system with plenty of fresh water to prevent corrosion.

### Lubrication

Oiling of the condenser fan motor or the evaporator blower motor is not recommended.



**Sever hazard. The economizer contains moving parts capable of causing serious injury or death. Disconnect power before removing the covering panel.**

# Chapter 7 Service & Charging/Recovery

## 7.1 Safety Precautions

### Service

Prior to beginning work on systems containing FLAMMABLE REFRIGERANTS, safety checks are necessary to ensure that the risk of ignition is minimized. For repair to the REFRIGERATING SYSTEM, the following shall be completed prior to conducting work on the system.

1. Work shall be undertaken under a controlled procedure to minimize the risk of flammable gas or vapor being present while the work is being performed.
2. All maintenance staff and others working in the local area shall be instructed on the nature of work being carried out. Work in confined spaces shall be avoided.
3. The area shall be checked with an appropriate refrigerant detector prior to and during work, to ensure the technician is aware of potentially toxic or flammable atmospheres. Ensure that the leak detection.
4. If any hot work is to be conducted on the refrigerating equipment or any associated parts, appropriate fire extinguishing equipment shall be available to hand. Have a dry powder or CO2 fire extinguisher adjacent to the charging area.
5. No person carrying out work in relation to a REFRIGERATING SYSTEM which involves exposing any pipe work shall use any sources of ignition in such a manner that it may lead to the risk of fire or explosion. All possible ignition sources, including cigarette smoking, should be kept sufficiently far away from the site of installation, repairing, removing and disposal, during which refrigerant can possibly be released to the surrounding space. Prior to work taking place, the area around the equipment is to be surveyed to make sure that there are no flammable hazards or ignition risks. “No Smoking” signs shall be displayed.
6. Ensure that the area is open or that it is adequately ventilated before breaking into the system or conducting any hot work. A degree of ventilation shall continue during the period that the work is carried out. The ventilation should safely disperse any released refrigerant and preferably expel it externally into the atmosphere.
7. The minimum test pressure for the low side of the system shall be the low side design pressure and the minimum test pressure for the high side of the system shall be the high side design pressure, unless the high side of the system, cannot be isolated from the low side of the system in which case the entire system shall be pressure tested to the low side design pressure.

## 7.2 Leak Detection

Under no circumstances shall potential sources of ignition be used in the searching for or detection of refrigerant leaks. A halide torch (or any other detector using a naked flame) shall not be used. The following leak detection methods are deemed acceptable for all refrigerant systems. Electronic leak detectors may be used to detect refrigerant leaks but, in the case of FLAMMABLE REFRIGERANTS, the sensitivity may not be adequate, or may need re-calibration. (Detection equipment shall be calibrated in a refrigerant-free area.) Ensure that the detector is not a potential source of ignition and is suitable for the refrigerant used. Leak detection equipment shall be set at a percentage of the LFL of the refrigerant and shall be calibrated to the refrigerant employed, and the appropriate percentage of gas (25 % maximum) is confirmed. Leak detection fluids are also suitable for use with most refrigerants but the use of detergents containing chlorine shall be avoided as the chlorine may react with the refrigerant and corrode the copper pipework. **Note:** Examples of leak detection fluids are

1. Bubble method
2. Fluorescent method agents

If a leak is suspected, all naked flames shall be removed/extinguished. If a leakage of refrigerant is found which requires brazing, all of the refrigerant shall be recovered from the system, or isolated (by means of shut off valves) in a part of the system remote from the leak.

### 7.3 Charging Procedures

In addition to conventional charging procedures, the following requirements shall be followed.

1. Ensure that contamination of different refrigerants does not occur when using charging equipment. Hoses or lines shall be as short as possible to minimize the amount of refrigerant contained in them.
2. Cylinders shall be kept in an appropriate position according to the instructions.
3. Ensure that the REFRIGERATING SYSTEM is earthed prior to charging the system with refrigerant.
4. Label the system when charging is complete (if not already).
5. Extreme care shall be taken not to overfill the REFRIGERATING SYSTEM.
6. Prior to recharging the system, it shall be pressure-tested with the appropriate purging gas. The system shall be leak-tested on completion of charging but prior to commissioning. A follow up leak test shall be carried out prior to leaving the site.

Model (Single Stage)	Refrigerant Charge (Oz)	Model (2-Stage)	Refrigerant Charge (Oz)
MAH1018A	55	MAH2024A	95
MAH1020A	76	MAH2030A	90
MAH1024A	76	MAH2306A	105
MAH1024-1030A "B2"	110	MAH2042A	123
MAH1030A	90	MAH2048A	128
MAH1036A & "B2"	90	MAH2060A	125
MAH1042A	112	MGH2072A	150
MAH1048A	112		
MAH1060A	105		
MAH2072A	135		
MGH1072A	135		

**Table 11. Refrigerant Charge (R-454B, Ounces)**

### 7.4 Refrigerant Recovery

When removing refrigerants from a system, either for servicing or decommissioning, it is recommended good practice that all refrigerants are removed safely. When breaking into the refrigerant circuit to make repairs – or for any other purpose – conventional procedures shall be used. However, for flammable refrigerants it is important that best practice be followed, since flammability is a consideration. The following procedure shall be adhered to:

1. Safely remove refrigerant following local and national regulations.
2. Evacuate.
3. Continuously flush or purge with inert gas when using flame to open circuit
4. Open the circuit
5. The REFRIGERANT CHARGE shall be recovered into the correct recovery cylinders. For appliances containing FLAMMABLE REFRIGERANTS other than A2L REFRIGERANTS, the system shall be purged with oxygen-free nitrogen to render the appliance safe for FLAMMABLE REFRIGERANTS. This process may need to be repeated several times. Compressed air or oxygen shall not be used for purging refrigerant systems.

6. For appliances containing flammable refrigerants, refrigerants purging shall be achieved by breaking the vacuum in the system with oxygen-free nitrogen and continuing to fill until the working pressure is achieved, then venting to atmosphere, and finally pulling down to a vacuum (optional for A2L). This process shall be repeated until no refrigerant is within the system (optional for A2L). When the final oxygen-free nitrogen charge is used, the system shall be vented down to atmospheric pressure to enable work to take place
7. The outlet for the vacuum pump shall not be close to any potential ignition sources, and
8. Ventilation shall be available.
9. When transferring refrigerant into cylinders, ensure that only appropriate refrigerant recovery cylinders are employed. Ensure that the correct number of cylinders for holding the total system charge is available. All cylinders to be used are designated for the recovered refrigerant and labelled for that refrigerant (i.e. special cylinders for the recovery of refrigerant). Cylinders shall be complete with pressure-relief valve and associated shut-off valves in good working order. Empty recovery cylinders are evacuated and, if possible, cooled before recovery occurs.
10. The recovery equipment shall be in good working order with a set of instructions concerning the equipment that is at hand and shall be suitable for the recovery of the flammable refrigerant. If in doubt, the manufacturer should be consulted. In addition, a set of calibrated weighing scales shall be available and in good working order. Hoses shall be complete with leak-free disconnect couplings and in good condition.
11. The recovered refrigerant shall be processed according to local legislation in the correct recovery cylinder, and the relevant waste transfer note arranged. Do not mix refrigerants in recovery units and especially not in cylinders.
12. If compressors or compressor oils are to be removed, ensure that they have been evacuated to an acceptable level to make certain that flammable refrigerant does not remain within the lubricant. The compressor body shall not be heated by an open flame or other ignition sources to accelerate this process. When oil is drained from a system, it shall be carried out safely.

# Chapter 8 Decommissioning

## 8.1 Decommissioning

Before carrying out this procedure, it is essential that the technician is completely familiar with the equipment and all its details. It is recommended good practice that all refrigerants are recovered safely. Prior to the task being carried out, an oil and refrigerant sample shall be taken in case analysis is required prior to re-use of recovered refrigerant. It is essential that electrical power is available before the task commences.

1. Become familiar with the equipment and its operation.
2. Isolate the system electrically.
3. Before attempting the procedure, ensure that:
  - Mechanical handling equipment is available, if required, for handling refrigerant cylinders.
  - All personal protective equipment is available and being used correctly.
  - The recovery process is supervised at all times by a competent person.
  - Recovery equipment and cylinders conform to the appropriate standards.
4. Pump down the refrigerant system, if possible.
5. If a vacuum is not possible, make a manifold so that refrigerant can be removed from various parts of the system.
6. Make sure that cylinder is situated on the scales before recovery takes place.
7. Start the recovery machine and operate in accordance with instructions.
8. Do not overfill cylinders (no more than 80 % volume liquid charge).
9. Do not exceed the maximum working pressure of the cylinder, even temporarily.
10. When the cylinders have been filled correctly and the process completed, make sure that the cylinders and the equipment are removed from site promptly and all isolation valves on the equipment are closed off.
11. Recovered refrigerant shall not be charged into another REFRIGERATING SYSTEM unless it has been cleaned and checked.

Equipment shall be labelled stating that it has been de-commissioned and emptied of refrigerant. The label shall be dated and signed. For appliances containing FLAMMABLE REFRIGERANTS, ensure that there are labels on the equipment stating the equipment contains FLAMMABLE REFRIGERANT.

# Chapter 9 Start-Up Check List

## 9.1 Start-Up & Commissioning Form

Please complete the information on this form and return to Marvair by mail or fax. The mailing address and fax number can be found at the end of the form.

### A. Equipment Information

Date: \_\_\_\_\_ Equipment Owner \_\_\_\_\_

Installing Company: \_\_\_\_\_ Installer: \_\_\_\_\_

Address: \_\_\_\_\_ State \_\_\_\_\_

City: \_\_\_\_\_

ICE Air conditioner: Model No. \_\_\_\_\_

Serial No. \_\_\_\_\_

Compressor: Model No. \_\_\_\_\_

Serial No. \_\_\_\_\_

Compressor: Model No. \_\_\_\_\_

Serial No. \_\_\_\_\_

### B. Pre-Start Up

Is there any shipping damage?  Yes  No

If so, where? \_\_\_\_\_

Will this damage prevent starting the unit?  Yes  No

Check Power Supply, does it agree with data sticker on air conditioner?  Yes  No

Has the ground wire been connected?  Yes  No

Has the circuit protection been sized and installed properly?  Yes  No

### Controls

Are the thermostat control wiring connections made and checked?  Yes  No

Are all wiring terminals (including main power supply) tight?  Yes  No

If unit has a crankcase heater, has it been energized for 24 hours?  Yes  No

On a 208/230 v. units is control transformer (24 AC) wired for correct voltage?  Yes  No

### Condensate Section

Has water been placed in drain pan to confirm proper drainage?  Yes  No

Are correct filters in place?  Yes  No

### Refrigerant Piping

If leaks are found, report any leaks to the Marvair Warranty Service Dept.

**C. Check Rated Voltage at Terminal Block for Imbalance before starting of Unit.**

208/230V 1 Phase

208/230V 3 Phase

460V 3 Phase

380V 3 Phase 50Hz.

575 3 Phase 60 Hz.

Measured Line to Line Volts L1&L2 \_\_\_\_\_ V. L1&L3 \_\_\_\_\_ V. L2&L3 \_\_\_\_\_ V.

$(L1\&L2 + L1\&L3 + L2\&L3)/3 = \text{Avg. Voltage} = \underline{\hspace{2cm}}$

Max. Deviation from avg. voltage = \_\_\_\_\_ volts

Voltage imbalance =  $(100 \times \text{Max. Deviation})/\text{avg. Voltage} = \underline{\hspace{2cm}}\%$

*A voltage deviation greater than 2% with the unit running should be addressed and corrected. Excess voltage deviation can cause the compressor to overheat and to operate inefficiently.*

Example: 
$$\frac{\text{Maximum Deviation from Average Voltage} \times 100}{\text{Average voltage}} \text{ (for Percent)}$$

Measured Voltages:

L1 & L2 = 241 Volts

L1 & L3 = 243 Volts =  $717 / 3 = 239$  Average Voltage

L2 & L3 = 233 Volts

$239 - 233 = 6$

$100 \times 6/239 = 2.5\%$  Voltage Unbalance

Three phase units only check fan & compressor rotation.

### D. Heating Mode Check & Record Readings

	Circuit 1	Circuit 2 <i>(if applicable)</i>
Room Temperature	_____	_____
Outside Temperature	_____	_____
Evap. Entering Air DB Temp	_____	_____
Evap. Entering Air WB Temp	_____	_____
Evap. Leaving Air DB Temp	_____	_____
Evap. Leaving Air WB Temp	_____	_____
Heater Contactor Amps (L1)	_____	_____
Heater Contactor Amps (L2)	_____	_____
Heater Contactor Amps (L3)	_____	_____

### E. Cooling Mode Check & Record Refrigerant Pressures

Recheck voltage imbalance in cooling mode:

Measured Line to Line Volts L1&L2 \_\_\_\_\_ V. L1&L3 \_\_\_\_\_ V. L2&L3 \_\_\_\_\_ V.

$(L1\&L2 + L1\&L3 + L2\&L3)/3 = \text{Avg. Voltage} = \underline{\hspace{2cm}}$

Max. Deviation from avg. voltage = \_\_\_\_\_ volts

Voltage imbalance =  $(100 \times \text{Max. Deviation})/\text{avg. Voltage} = \underline{\hspace{2cm}}\%$



# Chapter 10 Warranty

## 10.1 Marvair, Inc. Limited Product Warranty

Marvair Inc., warrants its products to be free from defects in materials and workmanship under normal use to the original purchaser for the period of time in the table below. If any part of your product fails within 12 months from start-up, or 18 months from shipment from the factory, whichever comes first, Marvair, Inc. will furnish without charge, EXW Cordele, Georgia, the required replacement part. The owner must provide proof of the date of the original start-up. The contractor's invoice, the certificate of occupancy, or similar documents are examples of acceptable proof of the date of the original start-up.

<b>Marvair, ICE, Eubank Products</b>
90 Days <sup>1</sup> w/Flat Rate Labor <sup>2</sup> (See <i>Marvair, ICE, Eubank Flat Rate Labor Guidelines</i> )
1 Year Parts <sup>2,3</sup>
5 Years Compressor <sup>2</sup>

<sup>1</sup>If any part of your Marvair, Inc. unit fails within 90 days of the commencement of the warranty, Marvair, Inc. will furnish without charge, EX Works, Cordele, Georgia, the required replacement part and pay for the labor to replace the part in accordance with the Marvair, Inc. Flat Rate Labor Guidelines.

<sup>2</sup>All OTR (over the road) applications that are moved from one location to another: Factory Warranty applies only up to the point of initial start-up and test at all OEM manufacturing locations or subsequent facility. Once it goes into OTR service, the warranty expires immediately for compressor and sealed system components. This OTR exemption does not apply to relocatable classrooms, construction or office trailers.

<sup>3</sup>All warranty replacement parts shall be shipped Ground only. Expedited shipping is available upon request for additional cost.

The responsibility of the equipment owner includes:

1. To operate the equipment in accordance with the manufacturer's instructions.
2. To provide easy accessibility for servicing.
3. To check and reset any circuit breaker(s) and/or disconnect(s) prior to calling for service.
4. To keep the unit clean and free of dirt and containment and replace filters as required.
5. To keep the outdoor coil clean and free of leaves, paper, or other debris.
6. To pay the charges incurred when any of the above have not been done.
7. To pay for repair or replacement of any material or part other than those within the Marvair unit or controller.

Marvair, Inc., will not be responsible for labor after 90 days, transportation costs, delays or failures to complete repairs caused by events beyond our control (labor hours incurred due to required site-specific training, time waiting to gain access, or extended drive time for remote sites). This warranty does not cover:

1. Any transportation, related service labor, diagnosis calls, filter, driers, refrigerant, or any other material charges.
2. Damages caused by shipping, accident, abuse, negligence, misuse, fire, flood, or Acts of God.
3. Damages caused by operating or staging the unit in a corrosive environment.
4. Damages caused by improper application of the product.
5. Damages caused by failing to perform proper routine maintenance.
6. Expenses incurred for erecting, disconnecting or dismantling the product or installing the replacement part(s).
7. Products not installed or operated according to the included instructions, local codes, and good trade practices.
8. Products moved from the original installation site.
9. Products lost or stolen
10. Consequential damages or incidental expenses including losses to persons, property or business.
11. Modifications to original unit after it leaves the factory, such as breaking into any part of the sealed systems unless authorized in advance in writing by Marvair, Inc..
12. Damages as a result of operating as a construction site cooler / dehumidifier.

When labor (first 90 days only) is required, it must be performed during normal working hours (8:00 AM - 5:00 PM) Monday - Friday and must be performed by Marvair, Inc., personnel or a designated Service Representative.

The owner of the product may ship the allegedly defective or malfunctioning product or part to Marvair, Inc., at such owner's expense, and Marvair, Inc., will diagnose the defect and, if the defect is covered under this warranty, Marvair, Inc., will honor its warranty and furnish the required replacement part. All costs for shipment and risk of loss during shipment of the product to Marvair, Inc., and back to the owner shall be the responsibility and liability of the owner. Upon written request by an owner, Marvair, Inc., may arrange for remote diagnosis of the allegedly defective or malfunctioning product or part but all costs for transportation, lodging and related expenses with regard to such diagnostic services shall be the responsibility and liability of the owner.

An owner requesting performance under this Warranty shall provide reasonable access to the allegedly defective or malfunctioning product or part to Marvair, Inc., and its authorized agents and employees.

**THIS WARRANTY CONSTITUTES THE EXCLUSIVE REMEDY OF ANY PURCHASER OF A MARVAIR HEAT PUMP OR AIR CONDITIONER AND IS IN LIEU OF ALL OTHER WARRANTIES, EXPRESSED OR IMPLIED, INCLUDING, WITHOUT LIMITATION, ANY IMPLIED WARRANTY OF MERCHANTABILITY OR FITNESS FOR USE, TO THE FULLEST EXTENT PERMITTED BY LAW. IN NO EVENT SHALL ANY IMPLIED WARRANTY OF MERCHANTABILITY OR FITNESS FOR USE EXCEED THE TERMS OF THE APPLICABLE WARRANTY STATED ABOVE AND MARVAIR SHALL HAVE NO OTHER OBLIGATION OR LIABILITY. IN NO EVENT SHALL MARVAIR BE LIABLE FOR INCIDENTAL OR CONSEQUENTIAL DAMAGES OR MONETARY DAMAGES.**

THIS WARRANTY GIVES YOU SPECIFIC LEGAL RIGHTS, AND YOU MAY ALSO HAVE OTHER RIGHTS WHICH VARY FROM STATE-TO-STATE. Some states do not allow limitations or exclusions, so the above limitations and exclusions may not apply to you.

# APPENDIX A: Electronic Control Board Modbus Map

## Default Modbus RTU Settings

**Slave ID** = 1  
**Baud** = 19200  
**Data Bits** = 8  
**Stop Bits** = 1  
**Parity** = None  
 First Coil 1 , No. of Coils 30

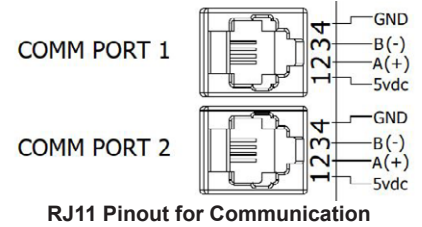

Discrete Bit/Bool: Read with Function Code 02 multi discrete input read, Write to RW coil with Function Code 05 Single Coil write. Coils and DI RO share a common space. Attempted Writes to RO DI inputs result in error return. Func 0x0F multiple coil writes not supported.

MODBUS PACKET REGISTER ZeroBase ID (ZBI)	Coil ID Value, Human OBI Reference Register ID				
OFFSET	ID	Description	Size	Data Format	R/W
0	1	Current Status of the Y1 Compressor Call	1 bit	0 = no call, 1 = call	RW
1	2	Current Status of the Y2 Compressor Call	1 bit	0 = no call, 1 = call	RW
2	3	Current Status of the Humidity Call	1 bit	0 = no call, 1 = call	RW
3	4	Current Status of the G Fan Call	1 bit	0 = no call, 1 = call	RW
4	5	Current Status of the W2 Electric Heating Call	1 bit	0 = no call, 1 = call	RW
5	6	Current Status of the FCC Call	1 bit	0 = no call, 1 = call	RO
6	7	High Pressure Switch 1 Status	1 bit	0 = Open, 1 = Closed	RO
7	8	High Pressure Switch 2 Status	1 bit	0 = Open, 1 = Closed	RO
8	9	Low Pressure Switch 1 Status (HPS2 HW input)	1 bit	0 = Open, 1 = Closed	RO
9	10	Low Pressure Switch 2 Status	1 bit	0 = Open, 1 = Closed	RO
10	11	OFM Mode Selection	1 bit	0 = PWM, 1 = 0-10V	RO
11	12	IFM Mode Selection	1 bit	0 = PWM, 1 = 0-10V	RO
12	13	Technician Speedup Test Mode Status	1 bit	0 = Normal Mode, 1 = Test Mode	RO
13	14	Status of Compressor 1 Relay Output	1 bit	0 = Off, 1 = Energized	RO
14	15	Status of Compressor 2 Relay Output	1 bit	0 = Off, 1 = Energized	RO
15	16	Status of RH RelayOutput	1 bit	0 = Off, 1 = Energized	RO
16	17	Status of W2 RelayOutput	1 bit	0 = Off, 1 = Energized	RO
17	18	Enables/1 or Disables/0 the communicating mode thermostat functionality. Reads/modifies parameter P22. 0=H,1=C	1 bit	0 = H hardware calls, 1 = Comm/Modbus calls.	RW
18	19	Enables or disables reading the hardware thermostat call inputs (Coils1-5,25).	1 bit	0 = Normal usage based on P22. 1 = read HW calls thermostat inputs regardless of programming of P22 as C. Default is 0, normal operations.	RW
19	20	Current Status of AC / HP	1 bit	0 = AC, 1 = HP	RO
20	21	Current Status of EHDD	1 bit	0 = N, 1 = Y	RO
21	22	Current Status of SCKT	1 bit	0 = N, 1 = Y	RO
22	23	Current Status of Enable Economizer	1 bit	0 = N, 1 = Y	RO
23	24	Current Status of Economizer Sensor Type	1 bit	0 = DB, 1 = EN	RO
24	25	Current Status of O Reversing Valve request	1 bit	0 = no call, 1 = call	RW
25	26	Current Status of RV output	1 bit	0 = OFF, 1 = Energized	RO
26	27	Emergency Ventilation Request	1 bit	0 = Off, 1 = Energized	RW
27	28	Pulse Reheat	1 bit	0 = off, 1 = ON (default)	RW
28	29	Status of Emergency Ventilation	1 bit	0 = Off, 1 = ON	RO
29	30	Status of EC relay output.	1 bit	0 = Off, 1 = ON	RO

Registers: Read with Function Code 04 Multi register reads, Write to RW register with Function Code 06 write single register. Attempted Writes to RO registers result in error return. Func 0x10 multiple register writes not supported.

MODBUS PACKET REGISTER ZeroBase ID (ZBI)	Human OBI Register ID				
	ID	Description	Size	Data Format	R/W
0	1	Heat Setpoint <b>Note:</b> Register is RW but not currently used. For future use.	16 bit	45-100 degrees Fahrenheit	RW
1	2	Cool Setpoint <b>Note:</b> Register is RW but not currently used. For future use.	16 bit	45-100 degrees Fahrenheit	RW
2	3	Temperature Calibration	16 bit	0-18, 9 is default. Less than 9 is a negative offset, 10-18 is a positive offset. Value minus 9 is the correction.	RW
3	4	W2 Speed Multiplier	16 bit	0-100, 80 is default. Represents a percentage of the Y2 fan speed	RW
4	5	Dehumidification Speed Multiplier	16 bit	0-100, 80 is default. Represents a percentage of the Y2 fan speed	RW
5	6	OFM Set Speed	16 bit	0 - 1023	RW
6	7	IFM Y1 Set Speed	16 bit	40-100, default = 60	RW
7	8	IFM Y2 Set Speed	16 bit	40-100, default = 60	RW
8	9	Modbus Timeout Setting	16 bit	1 - 60, default 10; represents minutes of allowed modbus inactivity before switching to HW call onboard t-stat mode	RW
9	10	Current OFM Speed	16 bit	0 - 1023	RO
10	11	Current IFM Speed	16 bit	0 - 1023	RO
11	12	Anti Short Cycle Compressor 1	16 bit	0 - 360, 0.5 seconds per step	RO
12	13	Anti Short Cycle Compressor 2	16 bit	0 - 360, 0.5 seconds per step	RO
13	14	Voltage Reading	16 bit	0-1023, 1023 = Greater than 20V 965 = 18V cutoff	RO
14	15	P1 Temperature Reading	16 bit	0-160 degrees Fahrenheit, 255 no sensor	RO
15	16	P2 Temperature reading	16 bit	0-160 degrees Fahrenheit, 255 no sensor	RO
16	17	Freeze Sensor 1 Temperature Reading	16 bit	0-160 degrees Fahrenheit, 255 no sensor	RO
17	18	Freeze Sensor 2 Temperature Reading	16 bit	0-160 degrees Fahrenheit, 255 no sensor	RO
18	19	Alarm Status	16 bit	0 = No Fault D0 = Freeze Sensor Fault D1 = HPS1 Fault D2 = Low Voltage D3 = Future Use D4 = Future Use D5 = Future Use D6 = LPS1 Fault D7 = Future Use D8 = Future Use D9 = Future Use D10 = Future Use D11 = Future Use D12 = Future Use D13 = Future Use D14 = Y1 Locked Out D15 = Y2 Locked Out	RO

19	20	Current Status of MIN POS	16 bit	20 = MIN, 20-100= OPEN %	RW
20	21	Economizer Dry Bulb Temperature setpoint	16 bit	70F=default, 20F-105F	RW
21	22	ODS set	16 bit	50 default, 0-70	RW
22	23	Fan Purge	16 bit	N= 0, 10-90 SECONDS, 90 SEC IS DEFAULT	RW
23	24	Defrost Timer	16 bit	30= default, 30, 60, 90 minutes	RW
24	25	Current SW version number	16 bit	display sw version decimal	RO
25	26	Supply/Mixed Air Temp reading	16 bit	0-160 degrees Fahrenheit	RO
26	27	SAS/MAS calibration	16 bit	0-18, 9 is default. Less than 9 is a negative offset, 10-18 is a positive offset. Value minus 9 is the correction.	RW
27	28	Outdoor Temp reading	16 bit	0-160 degrees Fahrenheit	RO
28	29	ODS Calibration	16 bit	0-18, 9 is default. Less than 9 is a negative offset, 10-18 is a positive offset. Value minus 9 is the correction.	RW
29	30	LPS1 / Suction Line Temp reading / freeze sensor	16 bit	0-160 degrees Fahrenheit, 255 if open or shorted sensor	RO
30	31	Suction Line Temp Calibration	16 bit	0-18, 9 is default. Less than 9 is a negative offset, 10-18 is a positive offset. Value minus 9 is the correction.	RW
31	32	FCC1 / Liquid Line temp reading	16 bit	0-160 degrees Fahrenheit, 255 if open or shorted sensor	RO
32	33	Liquid Line temp Calibration	16 bit	0-18, 9 is default. Less than 9 is a negative offset, 10-18 is a positive offset. Value minus 9 is the correction.	RW
33	34	DS Temp (defrost sensor temp) reading	16 bit	0-160 degrees Fahrenheit	RO
34	35	DS calibration	16 bit	0-18, 9 is default. Less than 9 is a negative offset, 10-18 is a positive offset. Value minus 9 is the correction.	RW
35	36	Dehumidifier Setpoint	16 bit	Default 72 F, 70 - 75F	RW
36	37	Pulse Reheat Differential	16 bit	Default 5 F, 5 - 10F	RW
37	38	Economizer setpoint Entropy Mode A..E as 0..4	16 bit	Default 3/D	RW
38	39	ECO output status	16 bit	0 = off, 20-100	RO
39	40	Head Pressure Cutout Temp	16 bit	75-95, 85 is default	RW
40	41	IFM G Set Speed	16 bit	30-100, default = 60	RW
41	42	OFM Speed Heating (Heatpumps)	16 bit	65-100, default = 85	RW

## APPENDIX B: Installation Instructions for Field Installed Electric Heat, Models MAH1024A-MAH1072A

### **WARNING** **FIRE HAZARD**

Improper adjustment, alteration, service, maintenance or installation could cause serious injury, death and/or property damage.

Installation or repairs made by unqualified persons could result in hazards to you and others. Installation **MUST** conform with local codes or, in the absence of local codes, with codes of all governmental authorities have jurisdiction.

The information contained in this manual is intended for use by a qualified service agency that is experienced in such work, is familiar with all precautions and safety procedures required in such work, and is equipped with the proper tools and test instruments.

### Duct Work

#### General Information

Note: The following instructions are for general guidance only. Due to the wide variety of installation possibilities, specific instructions will not be given. When in doubt, follow standard and accepted installation practices, or contact Marvair for additional assistance.

#### Wall Openings

Measure the dimensions of the supply and return ports on the unit.

Cut the openings in the exterior wall for the supply and return. **IMPORTANT: All units with electric heat must have 1" (25.4 mm) clearance on all four sides of the supply outlet duct flange on the unit. The 1" (25.4 mm) clearance must extend on all sides of the supply duct for the first 3 feet (1 meter) from the unit.**

**IMPORTANT: Marvair requires a minimum of 1" (25.4 mm) from the surface of any supply ducts to combustible material for the first 3 feet (1 meter) of the duct.**

#### Ducting

Extensions should be cut flush with the inside wall for applications without duct work.

Applications using duct work should be designed and installed in accordance with all applicable safety codes and standards. Marvair strongly recommends referring to the current edition of the National Fire Protection Association Standards 90A and 90B before designing and installing duct work. The duct system must be engineered to insure sufficient air flow through the unit to prevent over-heating of the heater element. This includes proper supply duct sizing, sufficient quantity of supply registers, adequate return and filter area. Ductwork must be of correct material and must be properly insulated. Duct work must be constructed of galvanized steel with a minimum thickness of .019 inches for the first 3 feet (1 meter). Ductwork must be firmly attached, secured and sealed to prevent air leakage. Do not use duct liner on inside of supply duct within 4 feet (122 cm) of the unit. Galvanized metal duct extensions should be used to simplify connections to duct work and grilles. Use fabric boots to prevent the transmission of vibration through the duct system. The fabric must be U.L. rated to a minimum of 197°F (92°C).

 **WARNING**

**ELECTRICAL SHOCK HAZARD**

**Failure to follow safety warnings exactly could result in serious injury, death, and/or property damage.**

**Turn off electrical power at fuse box or service panel BEFORE making any electrical connections and ensure a proper ground connection is made before connecting line voltage.**

**Heater installation (see drawings and wiring diagram)**

1. Remove top front panel.
2. Remove bottom front panel.
3. Remove the control box cover.
4. Remove the heater access cover plate on the upper right side of the unit by removing the three screws. Cut insulation on two sides and fold down out of way.
5. Slide new heater assembly into place by lining up stem with hole on far end. Make sure stem of new heater assembly is inserted into correct hole. The hole nearest to the indoor coil is for three element heaters and the farthest away from indoor coil is for all other heaters.
6. Install the two No. 10 screws in the heater assembly plate.
7. Install wire harness in hole provided in drain pan and then through filter bracket and then into control box.
8. Wire the heater as shown in the wiring diagram provided with the heater kit (the insulated terminal ends are to be connected at the heater)
9. Install pop tie in appropriate hole in back panel to secure wire.
10. Install closed cell strip around wires where they pass through the drain pan.
11. Reinstall the heater access cover.
12. Mount the heat contactor inside the control box where the mounting holes are provided for the heat contactor.
13. Make the wiring connections inside the control box as shown in the wiring diagram provided with the heater kit. Bundle loose wires with wire ties.
14. With a permanent marker, place an (X) in the space provided next to the heater kit rating of the installed heater on the unit data label.
15. Place the wiring diagram provided with the heater kit inside the zip lock bag which is affixed to the back side of the control box cover.
16. Replace the control box cover, the bottom front cover and the top front panel.

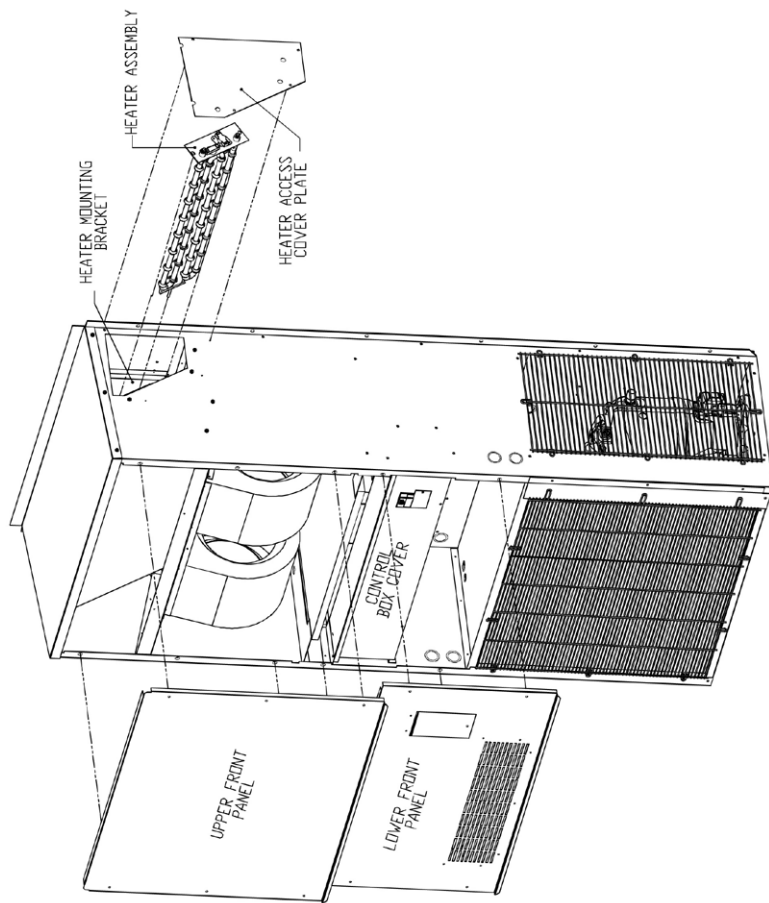

HEATER STEM INSTALLED IN HOLE ON FAR END

HEATER ASSEMBLY INSTALLED WITH TWO #10 SCREWS

