

Scholar 2.0 Heat Pumps & Air Conditioners:
Models VDH2024-2036-2040 & VAH2030-2048-2060
2 to 5 Ton Cooling Capacity with 2-Stage Compressors



Scholar 2.0

Designed,
Engineered
&
Assembled
in the USA

TABLE OF CONTENTS

General Description.....	1	Optional Controls	10
Scholar 2.0 Advantages.....	2	Model ID	11
Field Installed Accessories.....	4	Heat Pump Efficiency & Capacity Data.....	12
Louvers & Collar Options.....	5	Heat Pump Electrical Data.....	13
Air Distribution Options.....	5	A/C Efficiency & Capacity Data	15
Dehumidification Options	5	A/C Electrical Data	16
Heat Options	6	A/C & Heat Pump Hot Water Output	18
Cabinet Construction Options.....	6	Dehumidification Performance.....	19
Ventilation Options.....	6	Installed Weights & Filter Sizes	20
Optional Ventilation Controls & Grills	8	Dimensional Data.....	21
Thermostat/Controllers.....	8	Typical Installation Detail.....	23
Standard Controls.....	9	Wall Mounted Louver Detail.....	24

GENERAL DESCRIPTION

The Next Generation Scholar 2.0 VDH and VAH heat pumps and air conditioners are modular HVAC systems designed to provide heating, cooling, and outside fresh air for school classrooms. The units are installed in the classroom against an exterior wall. The vertical configuration minimizes the floor space occupied by the HVAC unit. This unique design makes it ideal for both new schools and for renovation of existing classrooms.

A full range of ventilation options – from the GreenCube[®] ERV, to a ventilation damper - are offered to meet any climate or budget. A wide selection of architectural louvers provides the designer with unlimited styles and configurations to compliment the exterior of the school. (For a complete description of the architectural louvers, please refer to the Marvair brochure entitled, "Architectural Extruded Aluminum Louvers.") Marvair offers a full range of thermostats to meet virtually every requirement. The unit can be controlled by a wall mounted thermostat, an internal thermostat or interfaced with a energy management system.

Scholar 2.0 heat pumps and air conditioners are available in cooling capacities from 2 to 5 tons with a 2-stage compressor (cooling only) as standard. Electric resistance or hot water is available as primary heat on the air conditioners and as second stage heat on the heat pump. All sizes are available for operation on 208/230 V. 1Ø or 3Ø and 460 V. 3Ø electrical supply. All models conform to UL/CSA standard 60335-1 and 60335-2-40 and CAN/CSA C22.2, No. 236-11 Ed.4 and listed by ETL.

Features and Benefits

Ease of Installation

- Modular construction for ease of upper floor installs
- ERV plate with no moving parts
- Air box height clears window sills
- Can be installed as free blow or ducted
- No clearance needed for corner installation
- Internal Electric Heat

Next Generation R-454B Refrigerant

- 78% Lower GWP than R-410A
- Non-Ozone Depleting Refrigerant
- Synthetic Lubricant
- Reduced Compressor Wear

Rugged Cabinet Construction

- Optional Double-Wall Cabinet constructed of 16 gauge galvanized steel
- Hinged doors with optional tamper resistant locks
- Non-Corrosive drain pans

GreenCube[®] Energy Recovery Ventilators (ERV)

- Removes Both Moisture and Heat from the Incoming Air Stream
- Optimized for Hot Gas Reheat

SCHOLAR 2.0 ADVANTAGES

Since their introduction in 1991, Scholar heat pumps and air conditioners have been the undisputed leader in interior, self-contained classroom HVAC systems. Students in tens of thousands of classrooms across the USA have benefited from the environment provided by Scholar heat pumps and air conditioners.

The Next Generation Scholar 2.0 builds on this history with unique design innovations and features.

➤ Exceeds DOE Efficiency Requirements

All Scholar 2.0 models are at least 11EER and 3.3 COP.

➤ Modular Construction for Ease of Installation

The upper module consists of a packaged air conditioner or heat pump while the lower module houses the ventilation section. These modules can be easily separated to reduce the height of the unit to fit through doors and inside elevators. This also reduces the weight that must be moved into position and eliminates the need to tilt the unit onto its side.

The Scholar 2.0 offers flexible installation options, including corner installs with no clearance requirement.

➤ Quiet Operation for a Better Learning Environment

The Scholar 2.0 meets and exceeds ANSI/ASHRAE Noise Criteria. A high efficiency axial fan moves air silently through the condenser coils. Specially designed interior panels absorb sound. A low vibration, scroll compressor insures quiet operation as well as energy efficiency. The indoor air mover utilizes a revolutionary electronically commutated motor (ECM). This motor consumes a minimum of power with whisper quiet operation. Throughout this Data Sheet features, options and components that minimize sound levels are designated by the "Quiet Zone" logo.

➤ High efficiency means lower operating costs

The latest in scroll compressor technology with ultra high efficiency indoor and outdoor air movers, generous lanced fin with rifled tube evaporator and condenser coils combine for Integrated Part Load Values (IPLV's) of up to 14.5.

➤ Humidity Control

The control of humidity is essential for a positive learning environment. Scholar 2.0 heat pumps and air conditioners actively control humidity with both standard controls and several optional accessories for schools where control of humidity is an everyday concern. The electronically commutated motor optimizes moisture removal by automatically controlling the air flow across the indoor coil. Unconditioned outdoor air for ventilation is not brought directly into the classroom. Ventilation air first passes through the indoor coil to temper the air and remove moisture. It then is mixed with classroom air before being introduced into the classroom.

➤ Scroll Compressor and R-454B Refrigerant

The heart of every air conditioner or heat pump is the compressor and the Scholar 2.0 utilizes a scroll compressor specifically designed to use next generation R-454B refrigerant. The heavy duty scroll compressor is quieter and operates with less damaging vibration than older compressors that operate on R-410A. Since R-454B can absorb and release heat more efficiently, they run cooler reducing the risk of burnout due to overheating.

➤ 2-Stage Compressor

Scholar 2.0 heat pumps and air conditioners come standard with a 2-stage compressor with a first stage capacity of 65% of the total capacity. The 2-stage compressor provides better comfort and improved energy efficiency compared to many older, single stage compressors.

➤ GreenCube® Energy Recovery Ventilator (ERV)

The optional GreenCube® ERV is a total energy recovery ventilator, removing both moisture and heat from the incoming air stream. With an outdoor wet bulb of 74°F and an indoor dry bulb of 72°F and 450 cfm of outside air, the GreenCube will remove 8 pints per hour of moisture from the incoming fresh air stream.

For optimum control of the humidity, the GreenCube® ERV should be used in conjunction with Hot Gas Reheat. This complete, factory assembled optional coil and controls economically maintains the temperature and humidity in the classroom.



LOW NOISE AND HIGH EFFICIENCY FEATURES



The Scholar 2.0 was designed from the onset for unsurpassed quiet operation and high efficiency. With the proper installation, sound levels of 45 dBA or less with a freeblow plenum can be obtained. With duct, sound levels can be greatly reduced. In addition, many of the same components that enable the Scholar 2.0 to have such quiet operation, contribute to its high efficiency.

► Electronically Commutated (EC) Indoor Air Mover Motor

Scholar 2.0 heat pumps and air conditioners use an Electronically Commutated (EC) motor for the indoor air mover and provides a number of advantages over conventional induction motors.

- **Constant Torque** Factory set, but can be adjusted in the field to compensate for high static filters, grilles or duct work. At a given torque setting, the EC motor has a lower drop in air flow with increasing static compared to a conventional PSC motor.
- **Quiet** The three phase brushless DC motor construction results in a very low torque ripple and the rotor construction effectively eliminates noise transmission through the shaft. Unlike a conventional induction motor that repeatedly cycles on & off, the EC motor is always powered, but cycled through an external low control voltage programmed to slowly ramp up to speed, eliminating the abrupt sound at start-up.
- **Ultra-High Efficiency** On constant fan speed, the motor consumes 60-80 watts compared to 400 watts for an induction motor.
- **Reliable** The motor's electronics are mounted on a potted single board design less susceptible to damage from moisture.

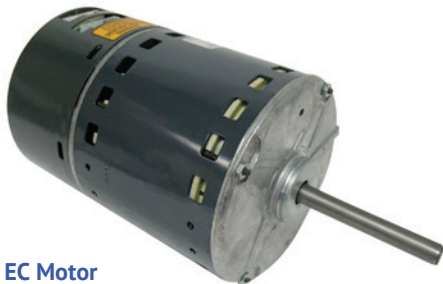

EC Motor

► 2-Stage Compressor

A two stage compressor offers better comfort and improved overall energy efficiency. The second stage is only functional in the cooling mode. Heating and dehumidification are single stage.

- **Better Comfort.** The two stage compressor is able to maintain more precise temperature and relative humidity levels. During mild days, the first stage can satisfy the load, minimizing temperature fluctuations providing steady, even comfort.
- **Energy Efficiency.** The Scholar 2.0 heat pump with the two stage high efficiency compressor can provide significant energy savings compared to older, less efficient systems.

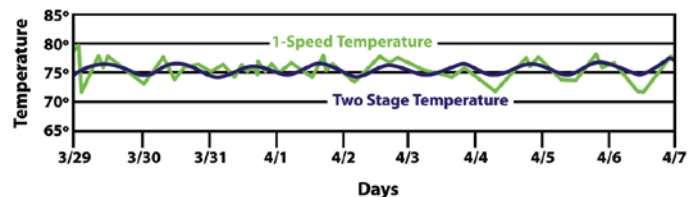

- **Hot Gas Reheat** for humidity control. The outside air requirements of classrooms require a special emphasis on control of humidity. The Scholar 2.0 with hot gas reheat and the two speed compressor provide a comprehensive, yet affordable solution. It is a complete factory assembled unit designed to provide dehumidification of fresh air and room air. See page 5 for a complete description of Hot Gas Reheat for dehumidification.

EASE OF INSTALLATION

Scholar 2.0 heat pumps and air conditioners are installed in the classroom against an exterior wall. The outdoor air box slides into an opening in the exterior wall. The outdoor air box provides for the ingress and egress of the condenser air as well as the intake and exhaust for the ventilation air. The bottom of the outdoor air box is adjustable from 24" to 33" from the base of the unit, enabling it to clear the sills of windows. For existing schools this greatly facilitates installation since expensive structural changes to exterior walls are not required. By having the fresh air intake three feet above grade, stagnant, moisture laden air is not introduced into the classroom.

Scholar 2.0 heat pumps and air conditioners can be installed as a free blow or ducted system. Free blow and ducted plenums are built in various heights to match the color and appearance of Scholar 2.0 units.

Scholar 2.0 units are available with a full range of accessories for customizing the installation including, base stands, decorative trim panels, and outdoor louvers.

The Scholar 2.0 is shipped with the outdoor air box not installed and is designed to be quickly installed in the field. This allows Scholar 2.0 heat pumps and air conditioners to fit comfortably through a three foot wide door.

SERVICE AND MAINTENANCE

All service and maintenance is performed from the front or side of the unit – there is no need to slide the unit away from the wall. The heavy duty hinged front panels open 180° to facilitate access to parts, air filters and controls. Both the indoor and outdoor coils are easily accessible for cleaning.

RUGGED CABINET CONSTRUCTION

The Scholar 2.0 internal structural is comprised of 16 gage galvanized steel and the exterior cabinet is constructed of 20 gage galvanized steel with a mark and scratch resistant polyester finish. A corrosion-resistant stainless steel drain pan is standard in all Scholar units. Grey is the standard cabinet color, but other colors are available.

The hinged doors permit easy access to the filters and components for service and maintenance. Tamper resistant locks which require a special tool are standard.

DEHUMIDIFICATION OPTIONS

► Reheat Dehumidification

Scholar 2.0 heat pumps and air conditioners with hot gas reheat are complete factory assembled units designed to provide dehumidification of fresh air and room air. Hot gas reheat can be used with the single stage or two stage compressor and with any supplemental heat and the GreenCube® ERV or motorized damper ventilation options. Hot gas reheat is controlled by an external humidity controller or BAS control. For optimum performance, hot gas reheat should be used in conjunction with the GreenCube® ERV. When used with the motorized damper, hot gas reheat alone may not maintain satisfactory control of the humidity in the classroom over all outdoor conditions.

A pulsing reheat valve maintains a constant discharge temperature during reheat operation. This temperature can be adjusted after installation.

Operation - If the humidity rises above the set point on the dehumidistat and the temperature in the classroom is satisfied, both mechanical cooling and the HGR coil operate to temper the air and lower the humidity. If the temperature in the classroom rises above (or falls below) the set point of the thermostat and the unit is operating in the dehumidification mode, the call for cooling (or heating) will override the call for dehumidification and the reheat coil is disengaged until the thermostat is satisfied. This assures the environment temperature is maintained as first priority and humidity control is second. Note: Scholar 2.0™ units with the hot gas reheat coil require a dehumidistat for proper operation. (See Optional Controls.)

HEAT OPTIONS

All heat options are available for the Scholar 2.0 heat pumps and air conditioners. Electric resistance or hot water heat is used as heat on air conditioners and to supplement, where required, the heat pump cycle.

► Electric Resistance Heat

Installs above the indoor air blowers inside the cabinet and is an integral part of the packaged unit. Refer to Model Identification table for available heat options.

► Hot Water Heat.....S/03249-GY

Installed above the indoor air blowers inside the plenum. Hot water coil capacities for the Scholar 2.0™ models are shown in the Hot Water Output data table. Hot water heat is factory installed in the freeblow plenum and is plumbed from the top right side of the plenum. As a standard safety feature, each hot water coil has a protective 24 volt thermostat embedded within it to shut off air flow across the coil if the coil temperature drops to 32°F. The Hot Water Plenum is 16.5" high (see *dimensional drawings*).

CABINET CONSTRUCTION OPTIONS

► Coastal Installations

For installation in coastal areas where salt corrosion may be a problem, the Scholar 2.0 heat pumps and air conditioners may be ordered with a stainless steel drain pan for the indoor coil and a corrosion resistant coating on the outdoor coils.

A MARVAIR® FIRST – FACTORY INSTALLED ECONOMIZER

Marvair Scholar 2.0 air conditioners and heat pumps have been the industry standard since their introduction. Tens of thousands of Marvair Scholar classroom units are in operation.

Here's how the economizer works: On a signal from the wall mounted indoor thermostat that cooling is required, either mechanical cooling with the compressor or free cooling with the optional economizer is provided. A factory installed

enthalpy controller determines whether the outside air is sufficiently cool and dry to be used for cooling. If suitable, the compressor is locked out and the economizer damper opens to bring in outside air. Integral pressure relief allows the interior air to exit the classroom, permitting outside air to enter the classroom. The temperature at which the economizer opens is adjustable from 63°F (17°C) at 50% Relative Humidity to 73°F (23°C) at 50% Relative Humidity.

After the enthalpy control has activated and outside air is being brought into the building, the mixed air sensor measures the temperature of the air entering the indoor blower and then modulates the economizer damper to mix the right proportion of cool outside air with warm indoor air to maintain 50-63°F (10 - 17°C) air being delivered to the building. This prevents shocking the electronic components with cold outside air. The compressor is not permitted to operate when the economizer is functioning.

If the outside air becomes too hot or humid, the economizer damper closes completely, or to a field selectable minimum open position, and mechanical cooling is activated.

VENTILATION OPTIONS

► Configuration “A”: Blank-Off Plate

No ventilation. No introduction of outside air. Available with PLC or control board.

► Configuration “C”: Economizer

The economizer reduces the cost of air conditioning by using outside air when acceptable to cool the room (Free Cooling). The factory installed Marvair® economizer has integral pressure relief.

When used with minimum position potentiometer (optional), the Marvair® economizer can meet requirements of ASHRAE Std. 62. Available only with PLC equipped Scholars.

► Configuration “E”: Motorized Fresh Air Damper w/Pressure Relief & Independent Control

This ventilation option allows the user to set the desired outside air intake from fully closed to fully open with independently adjusting intake and exhaust air movers and positive shut off with spring return dampers.” The PLC allows the position of the “E” damper to be set for desired outside air intake from fully closed to fully open. Setting 15 of the control board configuration menu allows the user to set the position from 20 (2VDC / Closed) to 100 (10VDC 100% open). The damper position can be adjusted in 1VDC increments to any position from closed to 100% open as required.

Operation: Upon a “Call for Motorized damper” via a 24V signal from an external user-installed device, the motorized damper opens to the position selected in the PLC configuration menu setting 15 and the indoor blower operates. A 24VAC signal {sourced from LVTB 24VAC “R” and supplied through a user-provided Normally Open (NO) contact} activates (opens) the Motorized Damper and connected Relief Damper. When the 24VAC signal is removed, the motorized damper spring returns to the fully closed position and the indoor blower stops operation. The motorized damper Does NOT open when there is a call for the indoor fan (G). This operation can be automatically controlled or manually controlled by a 24v AC signal.”

Note: This circuit does not interrupt the compressor or heater operation. Available only with PLC equipped Scholars.

► Configuration “N”: Manual Fresh Air Damper with Pressure Relief Ventilation (Standard)

Dedicated adjustable intake air mover. Adjustable up to 450 CFM with pressure relief. Available with PLC or control board.

► Configuration “Q”: GreenCube® ERV Ventilation (Optional)

The Marvair GreenCube ERV is an enthalpy plate heat exchanger that transfers both sensible and latent energies between outgoing and incoming air streams in a cross flow arrangement with virtually no cross-contamination of air streams. Except for two air movers, it has no moving parts. The media is impregnated with a polymeric desiccant that exchanges water by direct vapor transfer using molecular transport without the need of condensation. In addition, the desiccant is a bactericide. Two MERV 6 type filters are used on both sides of the enthalpy core. The fresh air and exhaust motors have independent speed controllers to permit each of the air movers to be regulated independently. Available only with PLC equipped Scholars.

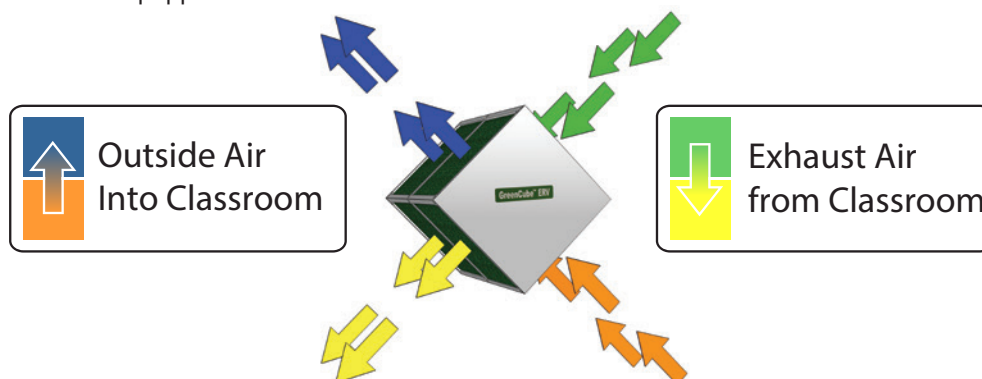

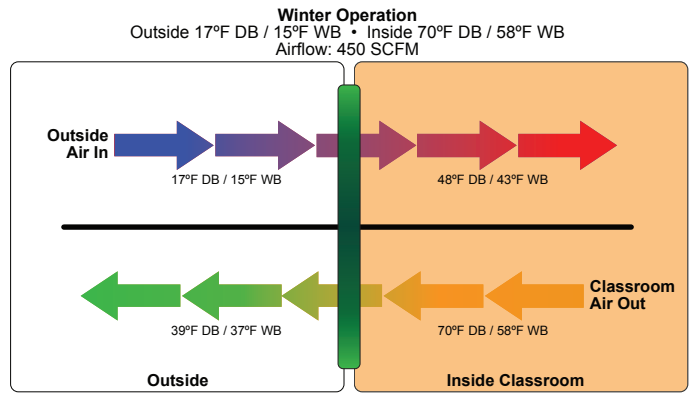
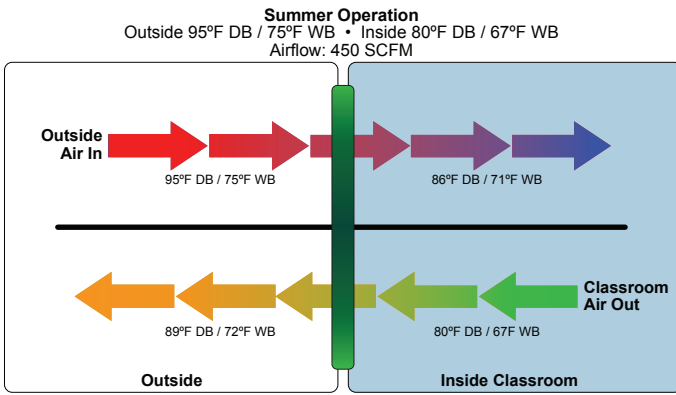

GreenCube Energy Recovery Ventilator Performance

SCFM* of Outside Air	Energy Conserved, BTUH					
	95° DB/73° WB Outside 80° DB/67° WB Inside			95° DB/80° WB Outside 80° DB/67° WB Inside		
	Sensible	Latent	Total	Sensible	Latent	Total
225	-2674	-823	-3497	-2674	-4790	-7463
250	-2952	-894	-3846	-2951	-5196	-8148
325	-3766	-1086	-4853	-3766	-6286	-10051
400	-4560	-1255	-5815	-4559	-7227	-11786
450	-5081	-1357	-6438	-5080	-7794	-12875

SCFM* of Outside Air	Energy Conserved, BTUH								
	90° DB/74° WB Outside 75° DB/64° WB Inside			80° DB/70° WB Outside 75° DB/64° WB Inside			60° DB/54° WB Outside 70° DB/58° WB Inside		
	Sensible	Latent	Total	Sensible	Latent	Total	Sensible	Latent	Total
225	-2575	-2765	-5341	-1035	-1877	-2913	1764	53	1817
250	-2842	-3002	-5844	-1144	-2031	-3175	1949	58	2007
325	-3623	-3641	-7264	-1463	-2437	-3900	2484	74	2558
400	-4384	-4197	-8581	-1775	-2780	-4555	3021	90	3111
450	-4883	-4536	-9418	-1981	-2983	-4964	3369	100	3469

SCFM* of Outside Air	Energy Conserved, BTUH								
	40° DB/36° WB Outside 70° DB/58° WB Inside			20° DB/18° WB Outside 70° DB/58° WB Inside			0° DB/7° WB Outside 70° DB/58° WB Inside		
	Sensible	Latent	Total	Sensible	Latent	Total	Sensible	Latent	Total
225	5288	2934	8222	8804	4365	13169	12314	4835	17149
250	5840	3240	9080	9722	4818	14540	13594	5335	18929
325	7441	4112	11553	12388	6108	18496	17328	6757	24085
400	9052	4921	13972	15066	7302	22368	21064	8070	29134
450	10091	5427	15518	16790	8049	24840	23466	8892	32358

*SCFM = Standard Cubic Feet per Minute

For performance of the GreenCube ERV at conditions other than those shown, please contact your Marvair® representative or the factory.

SCHOLAR VENTILATION OFFERING							
Model ID Pos. 13	Intake Motor	Exhaust Motor	Intake Damper	Exhaust Damper	Intake Filter	Exhaust Filter	Damper Actuator
A							
C	✓	✓	✓ (Barometric)	✓ (Barometric)	✓		✓
E	✓	✓	✓ (Barometric)	✓ (Barometric)	✓		✓
N	✓		✓ (Barometric)		✓		
Q	✓	✓			✓	✓	✓

Ventilation configurations "N" & "A" are available with either green board or PLC controls.
 Ventilation configurations "C", "E" & "Q" are ONLY available with PLC controls.

THERMOSTAT/CONTROLLERS

► Thermostats and Controllers for Marvair Scholar Heat Pumps and Air Conditioners

See the *Marvair Thermostats and Controllers Product Data Sheet* for the thermostats and controllers for use with Marvair Scholar heat pumps and air conditioners.

SCHOLAR 2.0 STANDARD CONTROLS

► High Pressure and Loss of Charge (HP) or Low Pressure (A/C) Switches

Includes a lockout relay.

► PLC Controller

The PLC is a factory installed Programmable Logic Controller. LED indicator lights show operational status and provide assistance with diagnosis if troubleshooting is ever required. The controller can perform extensive self diagnosis to assess the operational status and indicate a fault when detected. The controller can be programmed remotely or with a removable program storage device. Pertinent statistical data regarding the history of the refrigerant system is also stored.

The controller in the Scholar 2.0™ heat pumps and air conditioners improves reliability due to a reduction of components and simplification of control panel wiring and can control a Building Automation System (BAS) and various ventilation operations.

► Defrost Control

Based upon time and temperature. The time interval can be adjustable from 30 to 90 minutes in one minute increments. The control system initiates a defrost cycle only if the outdoor coil temperature is 28°F or below. (heat pump only)

► Anti-short Cycle Timer

Prevents the compressor's motor windings and starting controls from destructive overheating. The time interval is adjustable from three to eight minutes.

► EMS Control Relay (24V only)

Provides a 24 VAC coil to control operation from a Building Automation System.

Note: An additional EMS control relay can be added when 120 or 240 VAC coils are required.

► Outdoor Thermostat

Prevents second stage heat (electric or wet heat) from operating above desired outdoor temperature set point and can be set to activate second stage heat while disabling the compressor below desired outdoor temperature. (heat pump only)

► Electric Heat Control

Controls operation of electric heat and allows either simultaneous or non-simultaneous operation of electric heat and the compressor (heat pump only).

► Ventilation Control



The fresh air damper with PowerVent and GreenCube® ERV ventilation options are equipped with a Fresh Air Fan Speed Control. The fresh air fan controls the ventilation intake blower together, supplying up to 450 CFM of outside air if/when desired.

► Indoor Blower Fan Speed Controller

Allows field calibration of the indoor blower to minimize sound levels for specific installations.

► Phase Monitor

Monitors 3ø power supply and will not allow the unit to operate if the power supply is not properly phased. Not required on 1ø units.

► Condensate Float Switch

Shuts down the Scholar 2.0 unit in the event of a clogged condensate drain.

OPTIONAL CONTROLS

► Dehumidistat

Wall mounted type dehumidification controller controls operation of the hot gas reheat coil for dehumidification. Adjustable dehumidification range. Required for Scholar 2.0™ heat pumps and air conditioners with hot gas reheat.

OTHER OPTIONS

► Condensate Pans and Freeze Protection

To prevent freezing of water in the condensate lines and in the drain pans, this kit should be installed in locales subject to freezing temperatures. The kit includes a heater for the outdoor condensate pan.

► Anti-Microbial Light

A germicidal UV light destroys toxic bacteria, viruses and mold on the indoor air coil.

► **Cold Plasma Air Purification Device**

Installed inside the Scholar 2.0 unit, this device neutralizes odors, kills mold, bacteria and viruses. It also helps to control allergens*, asthma*, smoke and airborne particles.

*These statements are based on customer testimonials and have not been evaluated by the FDA.



Cold Plasma Air Purifier

► **MERV 11 or 13 Return Air Filters**

Factory installed two inch (51 cm) MERV 11 or 13 filters. Ultra high filtration material that removes most airborne mold, spores and dust. Replaces standard MERV 8 return air filters.

► **Protective Coil Coating Packages**

The Scholar 2.0 is available with corrosion protection coatings for the condenser and evaporator coils.

FIELD INSTALLED ACCESSORIES

Note: Color must be specified when ordering certain accessories. “-XXX” in the Part Number indicates color.
100 = Marvair Beige | 200 = Gray | 400 = White

► **Trim Piece**

The trim piece provides a color coordinated panel between the cabinet and the wall and is used to conceal a gap when the Scholar unit with the minimum depth Wall Sleeve is deeper than the wall. Built in the same color as the cabinet and in various widths. Trim pieces provide a finished appearance and cover any space between the back of the cabinet and the wall. Each Scholar unit requires two (2) Trim Pieces.

Description	Part Number
8” Trim Piece Kit.....	M/04054-XXX
9” Trim Piece Kit.....	M/04055-XXX
12” Trim Piece Kit.....	M/04056-XXX
15” Trim Piece Kit.....	M/04057-XXX
18” Trim Piece Kit.....	M/04058-XXX
21” Trim Piece Kit.....	M/04059-XXX

► **Base Stand**

A Base Stand matches the Scholar 2.0 cabinet and raises it off the floor to align the wall sleeve to different window sill heights. The Base Stand is available in several colors to match the color of the unit.

Description	Part Number
2” Base Stand.....	S/12948-XXX
3” Base Stand.....	S/13101-XXX
4” Base Stand.....	S/12903-XXX
5” Base Stand.....	S/13029-XXX
6” Base Stand.....	S/13147-XXX
7” Base Stand.....	S/13252-XXX
8” Base Stand.....	S/13102-XXX
9” Base Stand.....	S/13253-XXX
10” Base Stand.....	S/13185-XXX
12” Base Stand.....	S/12942-XXX
13” Base Stand.....	S/13254-XXX
14” Base Stand.....	S/13103-XXX
15” Base Stand.....	S/13104-XXX

► **Base Stand Trim Kit**

The decorative Base Stand Trim kit matches the Scholar 2.0 cabinet and is included when an 8” or taller Base Stand is required to match the existing window sill height.

Description	Part Number
8” Base Stand Trim Kit.....	S/13153-XXX
9” Base Stand Trim Kit.....	S/13250-XXX
10” Base Stand Trim Kit.....	S/13186-XXX
12” Base Stand Trim Kit.....	S/13152-XXX
13” Base Stand Trim Kit.....	S/13251-XXX
14” Base Stand Trim Kit.....	S/13151-XXX
15” Base Stand Trim Kit.....	S/13150-XXX

► **Dry Erase Board**

Self adhesive dry erase board measures 3’H x 4’W and provides an excellent surface for displaying student art or important announcements.

Description	Part Number
Dry Erase Board.....	.03867

► **Wall Sleeve**

Sheet metal panel assembly to transition from Scholar unit and outdoor louver.

Description	Part Number
44”H x 36”W x 13”D (Center)	S/12893
36”H x 36”W x 13”D (Offset LH/RH).....	S/12895
46”H x 38”W x 13”D	S/12936
46”H x 42”W x 13”D	S/12941
46”H x 34”W x 13”D (Closet).....	S/13264
44”H x 44”W x 13”D	S/12877

► **Outdoor Louver**

Aluminum louver for covering the outside wall opening. Available in dark bronze or clear anodized. Exterior louver includes 1/2” x 1/2” bird screen. See Dimensional Drawings.

Description	Part Number
Outdoor Louver	93206

► **Plenum Options**

Freeblow Plenum: Mounts to the top of the Scholar unit to direct airflow into the classroom when a ducted installation is not required. The front grille has individually adjustable louvers which provide a full range of airflow direction. Two side supply grilles with louvers enhance the air flow in the classroom. All grilles have a clear brushed aluminum finish to be used with Scholar 2.0 units with no heat or electric resistance heat.

Description	Part Number
10” Freeblow Plenum (Insulated With No Insulation Fiber Exposed)	S/13112-XXX
10.5” Freeblow Plenum (Insulated With No Insulation Fiber Exposed)	S/13034-XXX
12.5” Freeblow Plenum (Insulated With No Insulation Fiber Exposed - Standard)	S/12904-XXX

Ducted Plenum: Allows for easy installation of duct work using a flanged rectangular opening on the top of the plenum.

Description	Part Number
10.5” Ducted Plenum.....	S/12868-XXX
12.5” Ducted Plenum.....	S/12890-XXX

► **Freeblow Plenum Supply Grilles**

The frame and blades are 6063 extruded aluminum alloy with a 2000-R1 satin anodized finish. To eliminate corrosion and vibration, the frame is separated from the blade with injection molded bushings. All blades are air foil in design and are individually adjustable. A specially engineered channel on the outside of the frame holds an extruded flexible vinyl bulb gasket that produces a positive air seal at the mounting surface.

Description	Part Number
10” Freeblow Plenum Supply Grilles.....	S/13084

► **Hot Water Plenum Supply Grilles**

For use with the optional Hot Water Plenum.

Description	Part Number
Hot Water Plenum Front Supply Grille	80676
Hot Water Plenum Side Supply Grille	93237

► **Freeblow Plenum Extender**

A Freeblow Plenum Extender is used when the Scholar unit and Freeblow Plenum combination doesn’t reach the ceiling height of the classroom and a “column” floor to ceiling appearance is desired.

Description	Part Number
2” Freeblow Plenum Extender	S/13016-XXX
5” Freeblow Plenum Extender	S/13038-XXX
6” Freeblow Plenum Extender	S/13017-XXX
7” Freeblow Plenum Extender	S/13039-XXX
8.5” Freeblow Plenum Extender.....	S/13018-XXX
10” Freeblow Plenum Extender.....	S/13019-XXX
12” Freeblow Plenum Extender.....	S/13192-XXX
14” Freeblow Plenum Extender.....	S/13020-XXX
16” Freeblow Plenum Extender.....	S/13030-XXX
20” Freeblow Plenum Extender.....	S/13021-XXX
24” Freeblow Plenum Extender.....	S/13216-XXX
26” Freeblow Plenum Extender.....	S/13217-XXX
35” Freeblow Plenum Extender.....	S/13022-XXX
40” Freeblow Plenum Extender.....	S/13249-XXX

► **Scholar Unit Extender**

A Scholar Unit Extender is used to conceal ducting when the Scholar unit doesn't reach the ceiling height of the classroom in a ducted installation.

Description	Part Number
8" Scholar Unit Extender	S/13105-XXX
10" Scholar Unit Extender.....	S/13106-XXX
12" Scholar Unit Extender.....	S/13107-XXX
13" Scholar Unit Extender.....	S/13243-XXX
14" Scholar Unit Extender.....	S/13108-XXX
15" Scholar Unit Extender.....	S/13244-XXX
16" Scholar Unit Extender.....	S/13109-XXX
18" Scholar Unit Extender.....	S/13245-XXX
20" Scholar Unit Extender.....	S/13246-XXX
22" Scholar Unit Extender.....	S/13247-XXX
23" Scholar Unit Extender.....	S/13248-XXX

MODEL IDENTIFICATION

Example	V	D	H	2	0	4	8	A	D	0	5	0	Q	G	+	+	+	1	E	A	+	A	1	1	2	+	+	+	+	+
Position	1	2	3	4	5	6	7	8	9	10	11	12	13	14	15	16	17	18	19	20	21	22	23	24	25	26	27	28	29	30

1	Unit Designation/Family	V = Marvair Scholar Classroom Unit
2	Energy Efficiency Ratio (EER)	A = 11 EER D = 12 EER
3	Refrigerant Type	H = R-454B
4	Compressor Type/Quantity	2 = Staged/Step
5	Unit Capacity/Nominal Cooling (BTUH)	024 = 24,000 040 = 40,000
6		030 = 30,000 048 = 48,000
7		036 = 36,000 060 = 60,000
8	System Type	A = Air Conditioner H = Heat Pump
9	Power Supply (Volts-Hz-Phase)	A = 208/230-60-1 C = 208/230-60-3 D = 460-60-3
10	Heat Designation @ Rated Voltage KW = Kilowatt	000 = No Heat 100 = 10KW
11		050 = 5KW 120 = 12KW
12		060 = 6KW 150 = 15KW
12		080 = 8KW 990 = Hot Water Plenum
13	Ventilation Configuration	A = No Ventilation C = Economizer E = Adjustable Fresh-Air w/Powered Pressure Relief & Independent Control N = Manually Adjustable Fresh Intake w/ Fresh Air Filter & Adjustable Pressure Relief Q = GreenCube ERV
14	Dehumidification	H = Hot Gas Reheat w/Humidity Control G = Hot Gas Reheat M = Modulating Hot Gas Reheat R = Electric Reheat + = None
15	Controls	F = PLC w/Summed Alarms G = PLC w/Summed Alarms & Factory Installed T-Stat H = PLC w/BACnet J = PLC w/BACnet & Factory Installed T Stat + = None (Green Board)
16	Operating Condition	A = Evaporator Freeze Sensor (EFS) N = Hard Start P = Hard Start w/Low Ambient & CCH R = Crank Case Heater (CCH) Y = Low Ambient w/CCH Z = Low Ambient w/CCH & EFS 1 = Low Ambient w/FCC 2 = Low Ambient w/FCC & EFS + = None
17	Indoor Air Quality Features	D = Dry Bulb Sensor E = Dry Bulb Sensor w/Dirty Filter G = Dirty Filter Sensor K = Bi-Polar Ionization + = None

18	Air Flow	1 = Top Supply/Bottom Return C = Top Supply/Front Door Return
19	Compressor Location	E = Right Hand
20	Filter Option	A = 2" Pleated (MERV 8, AC/HP-C) C = 2" Charcoal D = MERV 11 High Filtration Package E = MERV 13 High Filtration Package + = None
21	Corrosion Protection	A = Condenser Coil Only C = Evaporator Coil Only D = Both Coils Condenser & Evaporator K = Coastal Package + = None \$ = Special
22	Engineering Revision Level	B1
24	Cabinet Color	1 = Marvair Beige (STD) 2 = Gray (STD) 3 = Carlsbad Canyon (STD) 4 = White (STD) 9 = Pebble Gray \$ = Custom Color (Powder Coat)
25	Sound Attenuation	2 = Compressor Blanket + = None
26	Security Option	A = Lockable Access Plate/Tamper Proof + = None
27	Fastener/Drain Pan Option	C = Stainless Steel Drain Pan + = None
28	Miscellaneous	% = Center Wall Sleeve (STD) / = Offset Wall Sleeve + = None \$ = Special
29	Unused	A = Double-Wall Front Doors + = None \$ = Special
30	Special Variation	+ = None \$ = Special Configuration Not Covered by Model Nomenclature

Note: Not all options are available with all configurations. Contact your Marvair sales representative for configuration details and feature compatibility.

ALTITUDE CORRECTION FACTOR

Altitude (Meters)	Altitude (Feet)	Correction Factor
0	0	1.00
200	660	1.00
400	1310	1.00
600	1970	1.00
800	2620	1.02
1000	3280	1.05
1200	3940	1.07
1400	4590	1.10
1600	5250	1.12
1800	5910	1.15
2000	6560	1.18
2200	7220	1.21
2400	7870	1.25
2600	8530	1.28
2800	9190	1.32
3000	9840	1.36
3200	10500	1.40
3400	11150	1.45
3600	11810	1.50
3800	12470	1.55
4000	13120	1.61
4200	13780	1.67
4400	14440	1.72
4600	15090	1.79
4800	15750	1.85
5000	16400	1.92

In accordance with UL 60335-2-40, for units above 600m, multiply the minimum room area stated in the table above by the correction factor that corresponds with the altitude the unit is located at. This will give you a new minimum room area that is adjusted for your altitude. The units listed in this manual are not intended for use above 5000 meters.

SCHOLAR 2.0 VAH/VDH HEAT PUMPS WITH 2-STAGE COMPRESSOR

Certified Efficiency and Capacity Ratings at ANSI/ARI Standard 390

Model Number	VDH2024H			VAH2030H			VDH2036H			VDH2040H			VAH2048H			VAH2060H		
	A	C	D	A	C	D	A	C	D	A	C	D	A	C	D	A	C	D
Cooling BTUH ¹ - 2nd Stage	22,200			27,000			34,400			42,000			45,000			56,000		
EER ² - 2nd Stage	12.00			11.00			12.00			12.00			11.50			11.00		
Integrated Part Load Value ³	15.5			14.0			15.5			16.0			15.5			14.2		
High Temperature Heating ⁴	20,400			25,000			26,600			34,400			36,000			50,000		
High Temperature COP ⁵	3.30			3.30			3.30			3.30			3.30			3.30		
Rated Indoor Air Flow (CFM ^{6,7})	950			1,000			1,300			1,500			1,600			1,800		
Rated Outdoor Air Flow ⁷	2,800			2,800			2,800			2,800			2,800			3,000		

¹Cooling rated at 95°F (35°C) outdoor and 80°F DB/67° WB (26.5°C DB/19.5°C WB) return air. ²EER=Energy Efficiency Ratio
³Integrated Part Load Value is an integrated efficiency measure from 1st and 2nd stage capacity modulation.
⁴High Temperature Heating & 5COP is rated at 47°F DB/43°WB (8.3°C DB/6.1°C WB) outdoor and 70°F (21.1°C) return air.
⁵COP=Coefficient of Performance ⁶CFM=Cubic Feet per Minute ⁷ECM Motor Set Point
Ratings are at 230 volts for 208/230 volt units ("A" & "C" models) and 460 volts for "D" models. Operation of units at a different voltage from that of the rating point will affect performance and air flow.

Sensible Total Heat Ratio @ 95°F (35°C) Outside Air DB

Model Number	VDH2024H			VAH2030H			VDH2036H			VDH2040H			VAH2048H			VAH2060H		
	A	C	D	A	C	D	A	C	D	A	C	D	A	C	D	A	C	D
Total Capacity	22,200			27,000			34,400			42,000			45,000			56,000		
Sensible Heat Ratio	0.77			0.78			0.75			0.75			0.74			0.68		
Sensible Capacity	17,200			21,000			25,800			31,500			33,300			38,300		
Rated Air Flow (CFM ¹)	950			1,000			1,300			1,500			1,600			1,600		

¹CFM=Cubic Feet per Minute
Sensible Heat Ratios based upon ANSI/AHRI std. 390 outdoor conditions of 95°F (35°C) outdoor and 80°F DB/67°F WB (26.5°C DB/19.5°C WB) return air.

Cooling Performance (BTUH) at Various Outdoor Temperatures

Model Number	Outdoor Temperature									
	75°F / 24°C	80°F / 26.5°C	85°F / 29°C	90°F / 32°C	95°F / 35°C	100°F / 38°C	105°F / 40.5°C	110°F / 43.3°C	115°F / 46°C	
VDH2024H	25,752	24,864	23,976	23,088	22,200	20,935	20,424	19,536	19,092	
VAH2030H	31,320	30,240	29,160	28,080	27,000	25,920	24,840	23,760	23,220	
VDH2036H	39,904	38,528	37,152	35,776	34,400	33,024	31,648	30,272	29,584	
VDH2040H	48,720	47,040	45,360	43,680	42,000	40,320	38,640	36,960	36,120	
VAH2048H	52,200	50,400	48,600	46,800	45,000	43,200	41,400	39,600	38,700	
VAH2060H	64,960	62,720	60,480	58,240	56,000	53,760	51,520	49,280	48,160	

Based upon ANSI/AHRI std. 390 return air conditions of 80°F DB/67°F WB (26.5°C DB/19.5°C WB) return air at rated air flow.

Heating Performance (BTUH) at Various Outdoor Temperatures

Model Number	Outdoor Temperature														
	0°F/-17.8°C	5°F/-15°C	10°F/-12.2°C	15°F/-9.4°C	20°F/-6.7°C	25°F/-3.9°C	30°F/-1.1°C	35°F/1.7°C	40°F/4.4°C	45°F/7.2°C	47°F/8.3°C	50°F/10°C	55°F/12.8°C	60°F/15.6°C	
VDH2024H	8,571	9,796	11,053	12,245	13,469	14,694	15,918	17,143	18,367	19,591	20,400	20,816	22,040	23,265	
VAH2030H	10,584	12,096	13,608	15,120	16,632	18,144	19,656	21,168	22,680	24,192	25,000	25,704	27,216	28,728	
VDH2036H	11,138	12,730	14,321	15,912	17,503	19,094	20,686	22,277	23,868	25,459	26,600	27,050	28,642	30,233	
VDH2040H	14,452	16,517	18,581	20,646	22,711	24,775	26,840	28,904	30,969	33,034	34,400	35,098	37,163	39,227	
VAH2048H	15,233	17,410	19,586	21,762	23,938	26,114	28,291	30,467	32,643	34,819	36,000	36,995	39,172	41,348	
VAH2060H	21,420	24,480	27,540	30,600	33,660	36,720	39,780	42,840	45,900	48,960	51,000	52,020	55,080	58,140	

Based upon AHRI 390 Return Air of 70°F (21.1°C) Dry Bulb / 60°F (15.6°C) Wet Bulb.

Room Size Limitations

Scholar 2.0 Heat Pumps	VDH2024H	VAH2030H	VDH2036H	VDH2040H	VAH2048H	VAH2060H
Refrigerant Charge (oz.)	160	170	200	200	210	220
Minimum Room Size (ft ²)	157.1	166.9	196.4	196.4	206.2	216.0
Minimum Supply Height (ft)	6.9	6.9	6.9	6.9	6.9	6.9

Electrical Characteristics - Compressor, Fan, Ventilation & Blower Motors - VAH/VDH Heat Pumps

Model Number	COMPRESSOR			OTHER MOTORS	OUTDOOR FAN			INDOOR BLOWER (ECM)			ENERGY RECOVERY VENTILATOR	
	VOLTS-HZ-PH	RLA ¹	LRA ²	VOLTS-HZ-PH	RPM ³	FLA ⁴	HP ⁵	RPM ³	FLA ⁴	HP ⁵	GREENCUBE™	
											OAM ⁶	EXM ⁷
VDH2024HA	208/230-60-1	10.3	62.0	208/230-60-1	1200	5.3	1/2	1500	2.5	1/2	1.40	0.35
VAH2030HA	208/230-60-1	14.6	82.0	208/230-60-1	1200	5.3	1/2	1500	2.5	1/2	1.40	0.35
VDH2036HA	208/230-60-1	14.6	90.0	208/230-60-1	1200	5.3	1/2	1500	5.0	1/2	1.40	0.35
VDH2040HA	208/230-60-1	18.2	106.0	208/230-60-1	1200	5.3	1/2	1500	5.0	1/2	1.40	0.35
VAH2048HA	208/230-60-1	18.3	138.0	208/230-60-1	1200	5.3	1/2	1500	5.0	1/2	1.40	0.35
VAH2060HA	208/230-60-1	25.2	147.3	208/230-60-1	1200	3.5	1/3	1500	6.0	3/4	1.40	0.35
VDH2024HC	208/230-60-3	6.3	56.0	208/230-60-1	1200	5.3	1/2	1500	2.8	1/2	1.40	0.35
VAH2030HC	208/230-60-3	7.9	66.0	208/230-60-1	1200	5.3	1/2	1500	2.8	1/2	1.40	0.35
VDH2036HC	208/230-60-3	9.9	82.0	208/230-60-1	1200	5.3	1/2	1500	5.0	1/2	1.40	0.35
VDH2040HC	208/230-60-3	11.5	114.0	208/230-60-1	1200	5.3	1/2	1500	5.0	1/2	1.40	0.35
VAH2048HC	208/230-60-3	11.9	112.0	208/230-60-1	1200	5.3	1/2	1500	5.0	1/2	1.40	0.35
VAH2060HC	208/230-60-3	13.8	150.0	208/230-60-1	1200	3.5	1/3	1500	6.0	3/4	1.40	0.35
VDH2024HD	460-60-3	3.8	29.0	208/230-60-1	1200	5.3	1/2	1500	2.8	1/2	1.40	0.35
VAH2030HD	460-60-3	4.8	39.0	208/230-60-1	1200	5.3	1/2	1500	2.8	1/2	1.40	0.35
VDH2036HD	460-60-3	4.8	44.3	208/230-60-1	1200	5.3	1/2	1500	5.0	1/2	1.40	0.35
VDH2040HD	460-60-3	6.5	56.0	208/230-60-1	1200	5.3	1/2	1500	5.0	1/2	1.40	0.35
VAH2048HD	460-60-3	6.8	61.8	208/230-60-1	1200	5.3	1/2	1500	5.0	1/2	1.40	0.35
VAH2060HD	460-60-3	6.9	58.0	208/230-60-1	1200	3.5	1/3	1500	6.0	3/4	1.40	0.35

¹RLA = Rated Load Amps ²LRA = Locked Rotor Amps ³RPM = Revolutions per Minute ⁴FLA = Full Load Amps
⁵HP = Horsepower ⁶OAM - Outside Air Motor ⁷EXM-Exhaust Air Motor
 The 460 volt units have a step down transformer for the 230 volt motors.

Summary Electrical Ratings (Wire and Circuit Breaker Sizing) - VAH/VDH Heat Pumps with 2-Stage Compressor & Ventilation Configurations - ("C") Economizer ("N") Manually Adjustable Fresh Intake w/Fresh Air Filter & Adjustable Pressure Relief

ELECTRIC HEAT		000 = None		050 = 5 KW		060 = 6.0 KW		080 = 8.0 KW		090 = 9.0 KW		100 = 10 kWw		120 = 12 KW		150 = 15 KW	
BASIC MODEL	VOLTS-HZ-PH	SPPE ³		SPPE ³		SPPE ³		SPPE ³		SPPE ³		SPPE ³		SPPE ³		SPPE ³	
		MCA ¹	MFS ²	MCA ¹	MFS ²	MCA ¹	MFS ²	MCA ¹	MFS ²	MCA ¹	MFS ²	MCA ¹	MFS ²	MCA ¹	MFS ²	MCA ¹	MFS ²
VDH2024HA	208/230-60-1	20.7	30	46.7	50			62.3	70			72.8	80				
VAH2030HA	208/230-60-1	26.1	40	52.1	60			67.7	70			78.1	80				
VDH2036HA	208/230-60-1	28.6	40	54.6	60			70.2	80			80.6	90				
VDH2040HA	208/230-60-1	33.1	50	59.1	70			74.7	80			85.1	90				
VAH2048HA	208/230-60-1	33.2	50	59.2	70			74.8	80			85.3	90				
VAH2060HA	208/230-60-1	41.0	60	67.0	80			82.7	90			93.1	100				
VDH2024HC	208/230-60-3	16.0	20			34.0	35			43.0	45			52.1	60	61.1	70
VAH2030HC	208/230-60-3	18.0	25			36.0	40			45.0	50			54.1	60	63.1	70
VDH2036HC	208/230-60-3	22.7	30			40.7	45			49.7	50			58.8	60	67.8	70
VDH2040HC	208/230-60-3	24.7	35			42.7	50			51.7	60			60.8	70	69.8	70
VAH2048HC	208/230-60-3	25.2	35			43.2	50			52.2	60			61.3	70	70.3	80
VAH2060HC	208/230-60-3	26.8	40			44.8	50			53.8	60			62.8	70	71.9	80
VDH2024HD	460-60-3	8.8	15			17.8	20			22.3	25			26.8	30	31.4	35
VAH2030HD	460-60-3	10.1	15			19.1	20			23.6	25			28.1	30	32.6	35
VDH2036HD	460-60-3	11.2	15			20.2	25			24.7	25			29.2	30	33.7	35
VDH2040HD	460-60-3	13.3	15			22.3	25			26.8	30			31.3	35	35.8	40
VAH2048HD	460-60-3	13.7	20			22.7	25			27.2	30			31.7	35	36.2	40
VAH2060HD	460-60-3	13.4	20			22.4	25			26.9	30			31.4	35	35.9	40

¹MCA = Minimum Circuit Ampacity (Wiring Size Amps) ²MFS = Maximum Fuse or HACR Breaker Size ³SPPE = Single Point Power Entry

MCA & MFS are calculated at 230 volts on the "A" & "C" models and 460v on the "D" models. This chart should only be used as a guideline for estimating conductor size and overcurrent protection. For the requirements of specific units, always refer to the data label on the unit.

- MFS (Maximum Fuses Size) value listed is the maximum value as per UL 60335-2-40 calculations for MOCP (branch-circuit conductor sizes in this chart are based on this MOCP). The actual factory installed Overcurrent Protective Device (Circuit Breaker) in the models may be lower than the maximum UL 60335-2-40 allowable MOCP value, but still above the UL 60335-2-40 minimum calculated value or Minimum Circuit Ampacity (MCA) listed.
- The end user shall size conductors based on the Single Point Power Entry (SPPE) - Minimum Circuit Ampacity. The service circuit breaker shall not be sized less than the minimum circuit ampacity associated to Single Point Power Entry value provided. The service circuit breaker shall also not be sized greater than the Maximum Fuse size associated to the Single Point Power Entry Value Provided.
- While this electrical data is presented as a guide, it is important to electrically connect properly sized fuses and conductor wires in accordance with the National Electrical Code and all local codes.

Summary Electrical Ratings (Wire and Circuit Breaker Sizing) – VAH/VDH Heat Pumps with Ventilation Configuration -

("A") No Ventilation

("E") Adjustable Fresh-Air w/Powered Pressure Relief & Independent Control

("Q") GreenCube® Energy Recovery Ventilator

ELECTRIC HEAT		000 = None		050 = 5 KW		060 = 6.0 KW		080 = 8.0 KW		090 = 9.0 KW		100 = 10 KW		120 = 12 KW		150 = 15 KW	
BASIC MODEL	VOLTS-HZ-PH	SPPE ³		SPPE ³		SPPE ³		SPPE ³		SPPE ³		SPPE ³		SPPE ³		SPPE ³	
		MCA ¹	MFS ²	MCA ¹	MFS ²	MCA ¹	MFS ²	MCA ¹	MFS ²	MCA ¹	MFS ²	MCA ¹	MFS ²	MCA ¹	MFS ²	MCA ¹	MFS ²
VDH2024HA	208/230-60-1	22.4	30	48.5	50			64.1	70			74.5	80				
VAH2030HA	208/230-60-1	27.8	40	53.8	60			69.5	70			79.9	80				
VDH2036HA	208/230-60-1	30.3	40	56.3	60			72.0	80			82.4	90				
VDH2040HA	208/230-60-1	34.8	50	60.8	70			76.5	80			86.9	90				
VAH2048HA	208/230-60-1	34.9	50	61.0	70			76.6	80			87.0	90				
VAH2060HA	208/230-60-1	42.8	60	68.8	80			84.4	100			94.8	100				
VDH2024HC	208/230-60-3	17.7	20			35.8	40			44.8	45			53.8	60	62.8	70
VAH2030HC	208/230-60-3	19.7	25			37.8	40			46.8	50			55.8	60	64.8	70
VDH2036HC	208/230-60-3	24.4	30			42.5	45			51.5	60			60.5	70	69.5	70
VDH2040HC	208/230-60-3	26.4	35			44.5	50			53.5	60			62.5	70	71.5	80
VAH2048HC	208/230-60-3	26.9	35			45.0	50			54.0	60			63.0	70	72.0	80
VAH2060HC	208/230-60-3	28.5	40			46.5	50			55.6	60			64.6	70	73.6	80
VDH2024HD	460-60-3	9.7	15			18.7	20			23.2	25			27.7	30	32.2	35
VAH2030HD	460-60-3	10.9	15			19.9	20			24.5	25			29.0	30	33.5	35
VDH2036HD	460-60-3	12.0	15			21.0	25			25.6	30			30.1	35	34.6	35
VDH2040HD	460-60-3	14.2	20			23.2	25			27.7	30			32.2	35	36.7	40
VAH2048HD	460-60-3	14.5	20			23.5	25			28.1	30			32.6	35	37.1	40
VAH2060HD	460-60-3	14.3	20			23.3	25			27.8	30			32.3	35	36.8	40

¹MCA = Minimum Circuit Ampacity (Wiring Size Amps) ²MFS = Maximum Fuse or HACR Breaker Size ³SPPE = Single Point Power Entry

MCA & MFS are calculated at 230 volts on the "A" & "C" models and 460v on the "D" models. This chart should only be used as a guideline for estimating conductor size and overcurrent protection. For the requirements of specific units, always refer to the data label on the unit.

- MFS (Maximum Fuses Size) value listed is the maximum value as per UL 60335-2-40 calculations for MOCP (branch-circuit conductor sizes in this chart are based on this MOCP). The actual factory installed Overcurrent Protective Device (Circuit Breaker) in the models may be lower than the maximum UL 60335-2-40 allowable MOCP value, but still above the UL 60335-2-40 minimum calculated value or Minimum Circuit Ampacity (MCA) listed.
- The end user shall size conductors based on the Single Point Power Entry (SPPE) - Minimum Circuit Ampacity. The service circuit breaker shall not be sized less than the minimum circuit ampacity associated to Single Point Power Entry value provided. The service circuit breaker shall also not be sized greater than the Maximum Fuse size associated to the Single Point Power Entry Value Provided.
- While this electrical data is presented as a guide, it is important to electrically connect properly sized fuses and conductor wires in accordance with the National Electrical Code and all local codes.

Unit Load Amps (Heating) - VAH/VDH Heat Pumps

Electric Heat				Heat Pumps ¹ (Amps)		Load Of Resistive Heating Element										Total Maximum Heating ² (Electrical)											
																Ventilation Configuration "C, N"						Ventilation Configuration "A, E, Q"					
				Ventilation Configuration		Heating Element (KW)										Heating Element (KW)						Heating Element (KW)					
Model	RLA	ID mtr	OTD Mtr	N	A, E, Q	5	6	8	9	10	12	15	5	6	8	9	10	12	15	5	6	8	9	10	12	15	
VDH2024HA	10.3	2.5	5.3	18.1	19.9	20.8		33.3		41.7			40.3		52.8		61.2			38.9		51.4		59.8			
VAH2030HA	14.6	2.5	5.3	22.4	24.2	20.8		33.3		41.7			41.6		54.1		62.5			43.2		55.7		64.1			
VDH2036HA	14.6	5.0	5.3	24.9	26.7	20.8		33.3		41.7			46.3		58.8		67.2			45.7		58.2		66.6			
VDH2040HA	18.2	5.0	5.3	28.5	30.3	20.8		33.3		41.7			49.0		61.5		69.9			49.3		61.8		70.2			
VAH2048HA	18.3	5.0	5.3	28.6	30.4	20.8		33.3		41.7			52.2		64.7		73.1			49.4		61.9		70.3			
VAH2060HA	25.2	6.0	3.5	34.7	36.5	20.8		33.3		41.7			57.4		69.9		78.3			55.5		68.0		76.4			
VDH2024HC	6.3	2.8	5.3	14.4	16.2		14.4		21.7		28.9	36.1	29.0		36.3		43.5	50.7		30.6		37.8		45.0	52.2		
VAH2030HC	7.9	2.8	5.3	16.0	17.8		14.4		21.7		28.9	36.1	31.1		38.4		45.6	52.8		32.2		39.4		46.6	53.8		
VDH2036HC	9.9	5.0	5.3	20.2	22.0		14.4		21.7		28.9	36.1	36.3		43.6		50.8	58.0		34.6		41.9		49.1	56.3		
VDH2040HC	11.5	5.0	5.3	21.8	23.6		14.4		21.7		28.9	36.1	38.8		46.1		53.3	60.5		36.2		43.5		50.7	57.9		
VAH2048HC	11.9	5.0	5.3	22.2	24.0		14.4		21.7		28.9	36.1	38.7		46.0		53.2	60.4		36.6		43.9		51.1	58.3		
VAH2060HC	13.8	6.0	3.5	23.3	25.1		14.4		21.7		28.9	36.1	40.4		47.7		54.9	62.1		37.7		45.0		52.2	59.4		
VDH2024HD	3.8	1.4	2.7	7.9	8.7		7.2		10.8		14.4	18.0	14.8		18.4		22.0	25.6		15.9		19.6		23.2	26.8		
VAH2030HD	4.8	1.4	2.7	8.9	9.7		7.2		10.8		14.4	18.0	15.6		19.2		22.8	26.4		16.9		20.6		24.2	27.8		
VDH2036HD	4.8	2.5	2.7	10.0	10.8		7.2		10.8		14.4	18.0	18.1		21.7		25.3	28.9		17.2		20.8		24.4	28.0		
VDH2040HD	6.5	2.5	2.7	11.7	12.5		7.2		10.8		14.4	18.0	18.6		22.2		25.8	29.4		18.9		22.5		26.1	29.7		
VAH2048HD	6.8	2.5	2.7	12.0	12.8		7.2		10.8		14.4	18.0	18.8		22.4		26.0	29.6		19.2		22.8		26.4	30.0		
VAH2060HD	6.9	3.0	1.8	11.7	12.5		7.2		10.8		14.4	18.0	19.3		22.9		26.5	30.1		18.9		22.5		26.1	29.7		

¹Heat Pump = Total Heat Pump Unit Amps (Electric Heat is not Operating).

²Total Maximum Heating Amps = Total Amps with the Compressor, Motors and Electric Heat Operating at the same time.

Heating kW is rated at 240 volts on the 208-230v. (HPA & HPC) models. Derate heater output by 25% for operation at 208 volts. Heating kW is rated at 480 volts on the HPD models. Three phase models contain single phase motor loads. Values shown are maximum phase loads. Loads are not equally balanced on each phase.

SCHOLAR 2.0 VAH/VDH AIR CONDITIONERS WITH 2-STAGE COMPRESSOR

Certified Efficiency and Capacity Ratings at ANSI/ARI Standard 390

Model Number	VDH2024A			VAH2030A			VDH2036A			VDH2040A			VAH2048A			VAH2060A		
	A	C	D	A	C	D	A	C	D	A	C	D	A	C	D	A	C	D
Cooling BTUH ¹ - 2nd Stage	22,200			27,000			34,400			42,000			45,000			56,000		
EER ² - 2nd Stage	12			11			12			12			11.5			11		
Integrated Part Load Value ³	15.5			14			15.5			16			15.5			14.2		
Rated Indoor Air Flow (CFM ⁴)	950			1,000			1,300			1,500			1,600			1,600		
Rated Outdoor Air Flow ⁵	2,800			2,800			2,800			2,800			2,800			3,000		

¹Cooling rated at 95°F (35°C) outdoor and 80°F DB/67° WB (26.5°C DB/19.5°C WB) return air. ²EER=Energy Efficiency Ratio
³Integrated Part Load Value is an integrated efficiency measure from 1st and 2nd stage capacity modulation.
⁴CFM=Cubic Feet per Minute ⁵ECM Motor Set Point
Ratings are at 230 volts for 208/230 volt units ("A" & "C" models) and 460 volts for "D" models. Operation of units at a different voltage from that of the rating point will affect performance and air flow.

Sensible Total Heat Ratio @ 95°F (35°C) Outside Air DB

Model Number	VDH2024A			VAH2030A			VDH2036A			VDH2040A			VAH2048A			VAH2060A		
	A	C	D	A	C	D	A	C	D	A	C	D	A	C	D	A	C	D
Total Capacity	22,200			27,000			34,400			42,000			45,000			56,000		
Sensible Heat Ratio	0.77			0.78			0.75			0.75			0.74			0.68		
Sensible Capacity	17,200			21,000			25,800			31,500			33,300			38,300		
Rated Air Flow (CFM ¹)	950			1,000			1,300			1,500			1,600			1,600		

¹CFM=Cubic Feet per Minute
Sensible Heat Ratios based upon ANSI/AHRI std. 390 outdoor conditions of 95°F (35°C) outdoor and 80°F DB/67°F WB (26.5°C DB/19.5°C WB) return air.

Cooling Performance (BTUH) at Various Outdoor Temperatures

Model Number	Outdoor Temperature									
	75°F / 24°C	80°F / 26.5°C	85°F / 29°C	90°F / 32°C	95°F / 35°C	100°F / 38°C	105°F / 40.5°C	110°F / 43.3°C	115°F / 46°C	
VDH2024A	25,752	24,864	23,976	23,088	22,200	20,935	20,424	19,536	19,092	
VAH2030A	31,320	30,240	29,160	28,080	27,000	25,920	24,840	23,760	23,220	
VDH2036A	39,904	38,528	37,152	35,776	34,400	33,024	31,648	30,272	29,584	
VDH2040A	48,720	47,040	45,360	43,680	42,000	40,320	38,640	36,960	36,120	
VAH2048A	52,200	50,400	48,600	46,800	45,000	43,200	41,400	39,600	38,700	
VAH2060A	64,960	62,720	60,480	58,240	56,000	53,760	51,520	49,280	48,160	

Based upon ANSI/AHRI std. 390 return air conditions of 80°F DB/67°F WB (26.5°C DB/19.5°C WB) return air at rated air flow.

Room Size Limitations

Scholar 2.0 Air Conditioners	VDH2024A	VAH2030A	VDH2036A	VDH2040A	VAH2048A	VAH2060A
Refrigerant Charge (oz.)	160	170	200	200	210	220
Minimum Room Size (ft ²)	157.1	166.9	196.4	196.4	206.2	216.0
Minimum Supply Height (ft)	6.9	6.9	6.9	6.9	6.9	6.9

Electrical Characteristics - Compressor, Fan, Ventilation & Blower Motors - VAH/VDH Air Conditioners

Model Number	COMPRESSOR			OTHER MOTORS	OUTDOOR FAN			INDOOR BLOWER (ECM)			ENERGY RECOVERY VENTILATOR	
	VOLTS-HZ-PH	RLA ¹	LRA ²	VOLTS-HZ-PH	RPM ³	FLA ⁴	HP ⁵	RPM ³	FLA ⁴	HP ⁵	GREENCUBE™	
											AMPS	
											OAM ⁶	EXM ⁷
VDH2024AA	208/230-60-1	10.3	62.0	208/230-60-1	1200	5.3	1/2	1500	2.5	1/2	1.40	0.35
VAH2030AA	208/230-60-1	14.6	82.0	208/230-60-1	1200	5.3	1/2	1500	2.5	1/2	1.40	0.35
VDH2036AA	208/230-60-1	14.6	90.0	208/230-60-1	1200	5.3	1/2	1500	5.0	1/2	1.40	0.35
VDH2040AA	208/230-60-1	18.2	106.0	208/230-60-1	1200	5.3	1/2	1500	5.0	1/2	1.40	0.35
VAH2048AA	208/230-60-1	18.3	138.0	208/230-60-1	1200	5.3	1/2	1500	5.0	1/2	1.40	0.35
VAH2060AA	208/230-60-1	25.2	147.3	208/230-60-1	1200	3.5	1/3	1500	6.0	3/4	1.40	0.35
VDH2024AC	208/230-60-3	6.3	56.0	208/230-60-1	1200	5.3	1/2	1500	2.8	1/2	1.40	0.35
VAH2030AC	208/230-60-3	7.9	66.0	208/230-60-1	1200	5.3	1/2	1500	2.8	1/2	1.40	0.35
VDH2036AC	208/230-60-3	9.9	82.0	208/230-60-1	1200	5.3	1/2	1500	5.0	1/2	1.40	0.35
VDH2040AC	208/230-60-3	11.5	114.0	208/230-60-1	1200	5.3	1/2	1500	5.0	1/2	1.40	0.35
VAH2048AC	208/230-60-3	11.9	112.0	208/230-60-1	1200	5.3	1/2	1500	5.0	1/2	1.40	0.35
VAH2060AC	208/230-60-3	13.8	150.0	208/230-60-1	1200	3.5	1/3	1500	6.0	3/4	1.40	0.35
VDH2024AD	460-60-3	3.8	29.0	208/230-60-1	1200	5.3	1/2	1500	2.8	1/2	1.40	0.35
VAH2030AD	460-60-3	4.8	39.0	208/230-60-1	1200	5.3	1/2	1500	2.8	1/2	1.40	0.35
VDH2036AD	460-60-3	4.8	44.3	208/230-60-1	1200	5.3	1/2	1500	5.0	1/2	1.40	0.35
VDH2040AD	460-60-3	6.5	56.0	208/230-60-1	1200	5.3	1/2	1500	5.0	1/2	1.40	0.35
VAH2048AD	460-60-3	6.8	61.8	208/230-60-1	1200	5.3	1/2	1500	5.0	1/2	1.40	0.35
VAH2060AD	460-60-3	6.9	58.0	208/230-60-1	1200	3.5	1/3	1500	6.0	3/4	1.40	0.35

¹RLA = Rated Load Amps ²LRA = Locked Rotor Amps ³RPM = Revolutions per Minute ⁴FLA = Full Load Amps
⁵HP = Horsepower ⁶OAM - Outside Air Motor ⁷EXM-Exhaust Air Motor
 The 460 volt units have a step down transformer for the 230 volt motors.

Summary Electrical Ratings (Wire and Circuit Breaker Sizing) - VAH/VDH Air Conditioners with 2-Stage Compressor & Ventilation

("C") Economizer

("N") Manually Adjustable Fresh Intake w/Fresh Air Filter & Adjustable Pressure Relief

ELECTRIC HEAT		000 = None		050 = 5 KW		060 = 6.0 KW		080 = 8.0 KW		090 = 9.0 KW		100 = 10 kW _w		120 = 12 KW		150 = 15 KW	
BASIC MODEL	VOLTS-HZ-PH	SPPE ³		SPPE ³		SPPE ³		SPPE ³		SPPE ³		SPPE ³		SPPE ³		SPPE ³	
		MCA ¹	MFS ²	MCA ¹	MFS ²	MCA ¹	MFS ²	MCA ¹	MFS ²	MCA ¹	MFS ²	MCA ¹	MFS ²	MCA ¹	MFS ²	MCA ¹	MFS ²
VDH2024AA	208/230-60-1	20.7	30	28.5	30			44.2	45			54.6	60				
VAH2030AA	208/230-60-1	26.1	40	28.5	40			44.2	45			54.6	60				
VDH2036AA	208/230-60-1	28.6	40	31.0	40			46.7	50			57.1	60				
VDH2040AA	208/230-60-1	33.1	50	33.1	50			46.7	50			57.1	60				
VAH2048AA	208/230-60-1	33.2	50	33.2	50			46.7	50			57.1	60				
VAH2060AA	208/230-60-1	41.0	60	41.0	60			47.7	60			58.1	60				
VDH2024AC	208/230-60-3	16.0	20			20.8	25			29.9	30			38.9	40	47.9	50
VAH2030AC	208/230-60-3	18.0	25			20.8	25			29.9	30			38.9	40	47.9	50
VDH2036AC	208/230-60-3	22.7	30			23.0	30			32.1	35			41.1	45	50.1	60
VDH2040AC	208/230-60-3	24.7	35			24.7	35			32.1	35			41.1	45	50.1	60
VAH2048AC	208/230-60-3	25.2	35			25.2	35			32.1	35			41.1	45	50.1	60
VAH2060AC	208/230-60-3	26.8	40			26.8	40			33.1	40			42.1	45	51.1	60
VDH2024AD	460-60-3	8.8	15			10.4	15.0			14.9	15.0			19.4	20.0	24.0	25.0
VAH2030AD	460-60-3	10.1	15.0			10.4	15.0			14.9	15.0			19.4	20.0	24.0	25.0
VDH2036AD	460-60-3	11.2	15			11.5	15			16.0	20			20.5	25	25.1	30
VDH2040AD	460-60-3	13.3	15			13.3	15			16.0	20			20.5	25	25.1	30
VAH2048AD	460-60-3	13.7	20			13.7	20			16.0	20			20.5	25	25.1	30
VAH2060AD	460-60-3	13.4	20			13.4	20			16.5	20			21.0	25	25.6	30

¹MCA = Minimum Circuit Ampacity (Wiring Size Amps) ²MFS = Maximum Fuse or HACR Breaker Size ³SPPE = Single Point Power Entry
MCA & MFS are calculated at 230 volts on the "A" & "C" models and 460v on the "D" models. This chart should only be used as a guideline for estimating conductor size and overcurrent protection. For the requirements of specific units, always refer to the data label on the unit.

1. MFS (Maximum Fuses Size) value listed is the maximum value as per UL 60335-2-40 calculations for MOCP (branch-circuit conductor sizes in this chart are based on this MOCP). The actual factory installed Overcurrent Protective Device (Circuit Breaker) in the models may be lower than the maximum UL 60335-2-40 allowable MOCP value, but still above the UL 60335-2-40 minimum calculated value or Minimum Circuit Ampacity (MCA) listed.
2. The end user shall size conductors based on the Single Point Power Entry (SPPE) - Minimum Circuit Ampacity. The service circuit breaker shall not be sized less than the minimum circuit ampacity associated to Single Point Power Entry value provided. The service circuit breaker shall also not be sized greater than the Maximum Fuse size associated to the Single Point Power Entry Value Provided.
3. While this electrical data is presented as a guide, it is important to electrically connect properly sized fuses and conductor wires in accordance with the National Electrical Code and all local codes.

**Summary Electrical Ratings (Wire and Circuit Breaker Sizing) –
VAH/VDH Air Conditioners with Ventilation Configuration -
("A") No Ventilation
("E") Adjustable Fresh-Air w/Powered Pressure Relief & Independent Control
("Q") GreenCube® Energy Recovery Ventilator**

ELECTRIC HEAT		000 = None		050 = 5 KW		060 = 6.0 KW		080 = 8.0 KW		090 = 9.0 KW		100 = 10 KW		120 = 12 KW		150 = 15 KW	
BASIC MODEL	VOLTS-HZ-PH	SPPE ³		SPPE ³		SPPE ³		SPPE ³		SPPE ³		SPPE ³		SPPE ³		SPPE ³	
		MCA ¹	MFS ²	MCA ¹	MFS ²	MCA ¹	MFS ²	MCA ¹	MFS ²	MCA ¹	MFS ²	MCA ¹	MFS ²	MCA ¹	MFS ²	MCA ¹	MFS ²
VDH2024AA	208/230-60-1	22.4	30	28.5	30			44.2	45			54.6	60				
VAH2030AA	208/230-60-1	27.8	40	28.5	40			44.2	45			54.6	60				
VDH2036AA	208/230-60-1	30.3	40	31.0	40			46.7	50			57.1	60				
VDH2040AA	208/230-60-1	34.8	50	34.8	50			46.7	50			57.1	60				
VAH2048AA	208/230-60-1	34.9	50	34.9	50			46.7	50			57.1	60				
VAH2060AA	208/230-60-1	42.8	60	42.8	60			47.7	60			58.1	60				
VDH2024AC	208/230-60-3	17.7	20			20.8	25			29.9	30			38.9	40	47.9	50
VAH2030AC	208/230-60-3	19.7	25			20.8	25			29.9	30			38.9	40	47.9	50
VDH2036AC	208/230-60-3	24.4	30			24.4	30			32.1	35			41.1	45	50.1	60
VDH2040AC	208/230-60-3	26.4	35			26.4	35			32.1	35			41.1	45	50.1	60
VAH2048AC	208/230-60-3	26.9	35			26.9	35			32.1	35			41.1	45	50.1	60
VAH2060AC	208/230-60-3	28.5	40			28.5	40			33.1	40			42.1	45	51.1	60
VDH2024AD	460-60-3	9.7	15			10.4	15			14.9	15			19.4	20	24.0	25
VAH2030AD	460-60-3	10.9	15			10.9	15			14.9	15			19.4	20	24.0	25
VDH2036AD	460-60-3	12.0	15			12.0	15			16.0	20			20.5	25	25.1	30
VDH2040AD	460-60-3	14.2	20			14.2	20			16.0	20			20.5	25	25.1	30
VAH2048AD	460-60-3	14.5	20			14.5	20			16.0	20			20.5	25	25.1	30
VAH2060AD	460-60-3	14.3	20			14.3	20			16.5	20			21.0	25	25.6	30

¹MCA = Minimum Circuit Ampacity (Wiring Size Amps) ²MFS = Maximum Fuse or HACR Breaker Size ³SPPE = Single Point Power Entry
MCA & MFS are calculated at 230 volts on the "A" & "C" models and 460v on the "D" models. This chart should only be used as a guideline for estimating conductor size and overcurrent protection. For the requirements of specific units, always refer to the data label on the unit.

1. MFS (Maximum Fuses Size) value listed is the maximum value as per UL 60335-2-40 calculations for MOCP (branch-circuit conductor sizes in this chart are based on this MOCP). The actual factory installed Overcurrent Protective Device (Circuit Breaker) in the models may be lower than the maximum UL 60335-2-40 allowable MOCP value, but still above the UL 60335-2-40 minimum calculated value or Minimum Circuit Ampacity (MCA) listed.
2. The end user shall size conductors based on the Single Point Power Entry (SPPE) - Minimum Circuit Ampacity. The service circuit breaker shall not be sized less than the minimum circuit ampacity associated to Single Point Power Entry value provided. The service circuit breaker shall also not be sized greater than the Maximum Fuse size associated to the Single Point Power Entry Value Provided.

While this electrical data is presented as a guide, it is important to electrically connect properly sized fuses and conductor wires in accordance with the National Electrical Code and all local codes.

Unit Load Amps (Heating) - VAH/VDH Air Conditioners

Electric Heat				Heat Pumps ¹ (Amps)		Load Of Resistive Heating Element										Total Maximum Heating ² (Electrical)										
																Ventilation Configuration "C, N"					Ventilation Configuration "A, E, Q"					
				Ventilation Configuration				Heating Element (KW)										Heating Element (KW)					Heating Element (KW)			
Model	RLA	ID mtr	OTD Mtr	N	A, E, Q	5	6	8	9	10	12	15	5	6	8	9	10	12	15	5	6	8	9	10	12	15
VDH2024AA	10.3	2.5	5.3	18.1	19.9	20.8	33.3	41.7					40.3	52.8	61.2					38.9	51.4	59.8				
VAH2030AA	14.6	2.5	5.3	22.4	24.2	20.8	33.3	41.7					41.6	54.1	62.5					43.2	55.7	64.1				
VDH2036AA	14.6	5.0	5.3	24.9	26.7	20.8	33.3	41.7					46.3	58.8	67.2					45.7	58.2	66.6				
VDH2040AA	18.2	5.0	5.3	28.5	30.3	20.8	33.3	41.7					49.0	61.5	69.9					49.3	61.8	70.2				
VDH2048AA	18.3	5.0	5.3	28.6	30.4	20.8	33.3	41.7					52.2	64.7	73.1					49.4	61.9	70.3				
VDH2060AA	25.2	6.0	3.5	34.7	36.5	20.8	33.3	41.7					57.4	69.9	78.3					55.5	68.0	76.4				
VDH2024AC	6.3	2.8	5.3	14.4	16.2		14.4	21.7		28.9	36.1		29.0	36.3		43.5	50.7		30.6	37.8		45.0	52.2			
VAH2030AC	7.9	2.8	5.3	16.0	17.8		14.4	21.7		28.9	36.1		31.1	38.4		45.6	52.8		32.2	39.4		46.6	53.8			
VDH2036AC	9.9	5.0	5.3	20.2	22.0		14.4	21.7		28.9	36.1		36.3	43.6		50.8	58.0		34.6	41.9		49.1	56.3			
VDH2040AC	11.5	5.0	5.3	21.8	23.6		14.4	21.7		28.9	36.1		38.8	46.1		53.3	60.5		36.2	43.5		50.7	57.9			
VDH2048AC	11.9	5.0	5.3	22.2	24.0		14.4	21.7		28.9	36.1		38.7	46.0		53.2	60.4		36.6	43.9		51.1	58.3			
VDH2060AC	13.8	6.0	3.5	23.3	25.1		14.4	21.7		28.9	36.1		40.4	47.7		54.9	62.1		37.7	45.0		52.2	59.4			
VDH2024AD	3.8	1.4	2.7	7.9	8.7		7.2	10.8		14.4	18.0		14.8	18.4		22.0	25.6		15.9	19.6		23.2	26.8			
VAH2030AD	4.8	1.4	2.7	8.9	9.7		7.2	10.8		14.4	18.0		15.6	19.2		22.8	26.4		16.9	20.6		24.2	27.8			
VDH2036AD	4.8	2.5	2.7	10.0	10.8		7.2	10.8		14.4	18.0		18.1	21.7		25.3	28.9		17.2	20.8		24.4	28.0			
VDH2040AD	6.5	2.5	2.7	11.7	12.5		7.2	10.8		14.4	18.0		18.6	22.2		25.8	29.4		18.9	22.5		26.1	29.7			
VDH2048AD	6.8	2.5	2.7	12.0	12.8		7.2	10.8		14.4	18.0		18.8	22.4		26.0	29.6		19.2	22.8		26.4	30.0			
VDH2060AD	6.9	3.0	1.8	11.7	12.5		7.2	10.8		14.4	18.0		19.3	22.9		26.5	30.1		18.9	22.5		26.1	29.7			

¹Heat Pump = Total Heat Pump Unit Amps (Electric Heat is not Operating).

²Total Maximum Heating Amps = Total Amps with the Compressor, Motors and Electric Heat Operating at the same time.

Heating kW is rated at 240 volts on the 208-230v. (HPA & HPC) models. Derate heater output by 25% for operation at 208 volts. Heating kW is rated at 480 volts on the HPD models. Three phase models contain single phase motor loads. Values shown are maximum phase loads. Loads are not equally balanced on each phase.

Hot Water Output - Heat Pumps & Air Conditioners

Model	Entering Air Temperature 70°F DB, 60°F WB		HOT WATER HEAT									
			180°F Entering Water Temperature - Water Flow (GPM)									
		2	4	6	8	10	12	14	16	18	20	
VDH2024 (A/C ONLY)	Indoor Air Flow	(CFM)	800									
	Total Capacity	(Btu/Hr)	44,359	56,790	62,475	65,757	67,900	69,412	70,539	71,413	72,111	72,683
	Leaving Air - DB	(°F)	120.5	134.6	141.1	144.8	147.3	149.0	150.3	151.3	152.0	152.7
	Leaving Air - WB	(°F)	75.1	78.6	80.0	80.9	81.4	81.8	82.1	82.3	82.4	82.6
	Leaving Fluid Temp.	(°F)	134.4	150.8	158.6	163.1	166.1	168.1	169.7	170.8	171.8	172.5
	Fluid Delta T	(°F)	45.6	29.2	21.4	16.9	13.9	11.9	10.3	9.2	8.2	7.5
	Water Press. Drop	(Ft - H ₂ O)	0.2	0.6	1.3	1.7	3.7	5.3	7.2	9.3	11.7	14.4
VAH2030	Indoor Air Flow	(CFM)	1,000									
	Total Capacity	(Btu/Hr)	47,529	62,536	69,762	74,030	76,863	78,887	80,408	81,595	82,549	83,333
	Leaving Air - DB	(°F)	113.3	126.9	133.5	137.4	140.0	141.8	143.2	144.3	145.1	145.8
	Leaving Air - WB	(°F)	73.2	76.7	78.3	79.2	79.8	80.2	80.5	80.8	80.9	81.1
	Leaving Fluid Temp.	(°F)	131.2	147.9	156.1	161.0	164.2	166.5	168.2	169.5	170.6	171.4
	Fluid Delta T	(°F)	48.8	32.1	23.9	19.0	15.8	13.5	11.8	10.5	9.4	8.6
	Water Press. Drop	(Ft - H ₂ O)	0.2	0.6	1.3	1.7	3.7	5.3	7.2	9.3	11.7	14.4
VDH2036	Indoor Air Flow	(CFM)	1,200									
	Total Capacity	(Btu/Hr)	49,916	67,067	75,662	80,826	84,297	86,800	88,693	90,179	91,378	92,367
	Leaving Air - DB	(°F)	107.9	120.9	127.4	131.3	133.9	135.8	137.3	138.4	139.3	140.1
	Leaving Air - WB	(°F)	71.8	75.2	76.8	77.8	78.4	78.8	79.2	79.4	79.6	79.8
	Leaving Fluid Temp.	(°F)	128.7	145.6	154.1	159.2	162.7	165.1	167.0	168.4	169.6	170.5
	Fluid Delta T	(°F)	51.3	34.4	25.9	20.8	17.3	14.9	13.0	11.6	10.4	9.5
	Water Press. Drop	(Ft - H ₂ O)	0.2	0.6	1.3	1.7	3.7	5.3	7.2	9.3	11.7	14.4
VDH2040	Indoor Air Flow	(CFM)	1,300									
	Total Capacity	(Btu/Hr)	50,903	69,001	78,218	83,797	87,569	90,297	92,368	93,977	95,313	96,401
	Leaving Air - DB	(°F)	105.6	118.3	124.8	128.7	131.3	133.2	134.7	135.8	136.7	142.8
	Leaving Air - WB	(°F)	71.2	74.5	76.2	77.1	77.8	78.2	78.6	78.8	79.1	80.4
	Leaving Fluid Temp.	(°F)	127.7	144.6	153.2	158.5	162.0	164.5	166.4	167.9	169.1	171.0
	Fluid Delta T	(°F)	52.3	35.4	26.8	21.5	18.0	15.5	13.6	12.1	10.9	9.0
	Water Press. Drop	(Ft - H ₂ O)	0.2	0.6	1.3	1.7	3.7	5.3	7.2	9.3	11.7	14.4
VAH2048	Indoor Air Flow	(CFM)	1,500									
	Total Capacity	(Btu/Hr)	52,575	72,363	82,703	89,070	93,405	96,561	98,969	100,870	102,412	103,688
	Leaving Air - DB	(°F)	101.9	113.9	120.2	124.0	126.7	128.6	130.1	131.2	132.1	132.9
	Leaving Air - WB	(°F)	70.1	73.4	75.0	76.0	76.7	77.1	77.5	77.8	78.0	78.2
	Leaving Fluid Temp.	(°F)	126.0	142.8	151.7	157.1	160.8	163.5	165.5	167.1	168.3	169.4
	Fluid Delta T	(°F)	54.0	37.2	28.3	22.9	19.2	16.5	14.5	12.9	11.7	10.6
	Water Press. Drop	(Ft - H ₂ O)	0.2	0.6	1.3	1.7	3.7	5.3	7.2	9.3	11.7	14.4
VAH2060	Indoor Air Flow	(CFM)	1,500									
	Total Capacity	(Btu/Hr)	53,944	75,197	86,539	93,624	98,477	102,031	104,753	106,909	108,663	110,118
	Leaving Air - DB	(°F)	98.9	110.3	116.3	120.1	122.7	124.6	126.1	127.2	128.2	129.0
	Leaving Air - WB	(°F)	69.2	72.4	74.0	75.0	75.7	76.2	76.5	76.8	77.0	77.2
	Leaving Fluid Temp.	(°F)	124.5	141.4	150.4	156.0	159.8	162.5	164.6	166.3	167.6	168.7
	Fluid Delta T	(°F)	55.5	38.6	29.6	24.0	20.2	17.5	15.4	13.7	12.4	11.3
	Water Press. Drop	(Ft - H ₂ O)	0.2	0.6	1.3	1.7	3.7	5.3	7.2	9.3	11.7	14.4

Dehumidification Charts

Full Capacity Dehumidification - Scholar 2.0 Model/VDH2024A with Hot Gas Reheat

Indoor Conditions Air Entering Indoor Coil		Outdoor Ambient	Capacity (Btu/Hr)			Indoor Air Flow	Indoor Supply Air	Moisture Removed (Approximate)		Operating Mode
DB / WB	% RH	DB	Total	Sensible	Latent	CFM	DB	Lbs / Hr	Pints / Hr	
75 / 62.5	50	75	25,650	21,651	3,999	860	51.2	3.8	3.6	Cooling
75 / 62.5	50	75	3,999	0	3,999	860	72.0	3.8	3.6	Dehumid.
75 / 65.5	60	75	27,102	16,852	10,250	860	54.3	9.7	9.3	Cooling
75 / 65.5	60	75	10,250	0	10,250	860	72.6	9.7	9.3	Dehumid.
75 / 68	70	75	28,332	14,796	13,536	860	56.9	12.8	12.2	Cooling
75 / 68	70	75	13,536	0	13,536	860	72.6	12.8	12.2	Dehumid.
65 / 63	90	75	25,896	11,075	14,821	860	56.8	14.0	13.4	Cooling
65 / 63	90	75	14,821	0	14,821	860	64.2	14.0	13.4	Dehumid.
80 / 67	50	95	24,000	18,110	5,890	860	57.5	5.6	5.4	Cooling
80 / 67	50	95	5,890	0	5,890	860	76.9	5.6	5.4	Dehumid.

Full Capacity Dehumidification - Scholar 2.0 Model VAH2030H/VAH2030A with Hot Gas Reheat

Indoor Conditions Air Entering Indoor Coil		Outdoor Ambient	Capacity (Btu/Hr)			Indoor Air Flow	Indoor Supply Air	Moisture Removed (Approximate)		Operating Mode
DB / WB	% RH	DB	Total	Sensible	Latent	CFM	DB	Lbs / Hr	Pints / Hr	
75 / 62.5	50	75	30,994	23,698	7,296	1,050	51.7	6.9	6.6	Cooling
75 / 62.5	50	75	7,296	0	7,296	1,050	73.6	6.9	6.6	Dehumid.
75 / 65.5	60	75	32,748	20,687	12,061	1,050	54.8	11.4	10.9	Cooling
75 / 65.5	60	75	12,061	0	12,061	1,050	74.0	11.4	10.9	Dehumid.
75 / 68	70	75	34,235	18,134	16,101	1,050	57.4	15.2	14.6	Cooling
75 / 68	70	75	16,101	0	16,101	1,050	74.2	15.2	14.6	Dehumid.
65 / 63	90	75	31,291	13,485	17,806	1,050	52.3	16.8	16.1	Cooling
65 / 63	90	75	17,806	0	17,806	1,050	64.8	16.8	16.1	Dehumid.
80 / 67	50	95	29,000	21,632	7,368	1,050	57.9	6.3	6.0	Cooling
80 / 67	50	95	7,368	0	7,368	1,050	78.5	6.3	6.0	Dehumid.

Full Capacity Dehumidification - Scholar 2.0 Model VDH2036H/VDH2036A with Hot Gas Reheat

Indoor Conditions Air Entering Indoor Coil		Outdoor Ambient	Capacity (Btu/Hr)			Indoor Air Flow	Indoor Supply Air	Moisture Removed (Approximate)		Operating Mode
DB / WB	% RH	DB	Total	Sensible	Latent	CFM	DB	Lbs / Hr	Pints / Hr	
75 / 62.5	50	75	37,406	26,904	10,502	1200	51.6	9.9	9.5	Cooling
75 / 62.5	50	75	10,502	0	10,502	1200	72.4	9.9	9.5	Dehumid.
75 / 65.5	60	75	39,524	23,680	15,844	1200	54.7	15.0	14.3	Cooling
75 / 65.5	60	75	15,844	0	15,844	1200	73.0	15.0	14.3	Dehumid.
75 / 68	70	75	41,318	20,411	20,907	1200	57.3	19.7	18.9	Cooling
75 / 68	70	75	20,907	0	20,907	1200	73.0	19.7	18.9	Dehumid.
65 / 63	90	75	37,765	16,028	21,737	1200	57.2	20.5	19.7	Cooling
65 / 63	90	75	21,737	0	21,737	1200	64.6	20.5	19.7	Dehumid.
80 / 67	50	95	35,000	25,148	9,852	1200	57.9	9.3	8.9	Cooling
80 / 67	50	95	9,852	0	9,852	1200	77.3	9.3	8.9	Dehumid.

Full Capacity Dehumidification - Scholar 2.0 Model VDH2040H/VDH2040A with Hot Gas Reheat

Indoor Conditions Air Entering Indoor Coil		Outdoor Ambient	Capacity (Btu/Hr)			Indoor Air Flow	Indoor Supply Air	Moisture Removed (Approximate)		Operating Mode
DB / WB	% RH	DB	Total	Sensible	Latent	CFM	DB	Lbs / Hr	Pints / Hr	
75 / 62.5	50	75	43,819	32,539	11,280	1300	50.7	10.7	10.2	Cooling
75 / 62.5	50	75	11,280	0	11,280	1300	73.4	10.7	10.2	Dehumid.
75 / 65.5	60	75	46,299	28,561	17,738	1300	53.8	16.8	16.1	Cooling
75 / 65.5	60	75	17,738	0	17,738	1300	73.8	16.8	16.1	Dehumid.
75 / 68	70	75	48,400	25,186	23,214	1300	56.5	22.0	21.1	Cooling
75 / 68	70	75	23,214	0	23,214	1300	74.1	22.0	21.1	Dehumid.
65 / 63	90	75	44,239	19,025	25,214	1300	51.3	23.8	22.9	Cooling
65 / 63	90	75	25,214	0	25,214	1300	67.8	23.8	22.9	Dehumid.
80 / 67	50	95	41,000	30,501	10,499	1300	57.1	9.9	9.5	Cooling
80 / 67	50	95	10,499	0	10,499	1300	78.4	9.9	9.5	Dehumid.

Full Capacity Dehumidification - Scholar 2.0 Model VAH2048H/VAH2048A with Hot Gas Reheat

Indoor Conditions Air Entering Indoor Coil		Outdoor Ambient	Capacity (Btu/Hr)			Indoor Air Flow	Indoor Supply Air	Moisture Removed (Approximate)		Operating Mode
DB / WB	% RH	DB	Total	Sensible	Latent	CFM	DB	Lbs / Hr	Pints / Hr	
75 / 62.5	50	75	52,369	37,675	14,694	1550	50.7	13.9	13.3	Cooling
75 / 62.5	50	75	14,694	0	14,694	1550	73.3	13.9	13.3	Dehumid.
75 / 65.5	60	75	55,333	33,215	22,118	1550	53.7	20.9	20.0	Cooling
75 / 65.5	60	75	22,118	0	22,118	1550	73.5	20.9	20.0	Dehumid.
75 / 68	70	75	57,845	29,424	28,421	1550	56.3	26.8	25.7	Cooling
75 / 68	70	75	28,421	0	28,421	1550	73.9	26.8	25.7	Dehumid.
65 / 63	90	75	52,871	25,548	27,323	1550	51.2	25.8	24.7	Cooling
65 / 63	90	75	27,323	0	27,323	1550	66.5	25.8	24.7	Dehumid.
80 / 67	50	95	49,000	35,191	13,809	1550	56.9	13.0	12.5	Cooling
80 / 67	50	95	13,809	0	13,809	1550	77.9	13.0	12.5	Dehumid.

Full Capacity Dehumidification - Scholar 2.0 Model/VAH2060A with Hot Gas Reheat

Indoor Conditions Air Entering Indoor Coil		Outdoor Ambient	Capacity (Btu/Hr)			Indoor Air Flow	Indoor Supply Air	Moisture Removed (Approximate)		Operating Mode
DB / WB	% RH	DB	Total	Sensible	Latent	CFM	DB	Lbs / Hr	Pints / Hr	
75 / 62.5	50	75	61,988	42,727	19,261	1650	50.2	18.2	17.4	Cooling
75 / 62.5	50	75	19,261	0	19,261	1650	74.2	18.2	17.4	Dehumid.
75 / 65.5	60	75	65,497	37,989	27,508	1650	53.2	26.0	24.9	Cooling
75 / 65.5	60	75	27,508	0	27,508	1650	74.5	26.0	24.9	Dehumid.
75 / 68	70	75	68,469	33,954	34,515	1650	55.7	32.6	31.2	Cooling
75 / 68	70	75	34,515	0	34,515	1650	74.8	32.6	31.2	Dehumid.
65 / 63	90	75	62,582	26,627	35,955	1650	51.1	33.9	32.5	Cooling
65 / 63	90	75	35,955	0	35,955	1650	66.0	33.9	32.5	Dehumid.
80 / 67	50	95	58,000	39,659	18,341	1650	56.1	17.3	16.6	Cooling
80 / 67	50	95	18,341	0	18,341	1650	78.4	17.3	16.6	Dehumid.

The Dehumidification Operating Mode is with Hot Gas Reheat.

Installed Weight

VDH2024	Base	w/Greencube	460V	w/GreenCube & 460V
Pounds	1020	1070	1045	1095

VAH2030	Base	w/Greencube	460V	w/GreenCube & 460V
Pounds	1020	1070	1045	1095

VDH2036	Base	w/Greencube	460V	w/GreenCube & 460V
Pounds	1020	1070	1045	1095

VDH2040	Base	w/Greencube	460V	w/GreenCube & 460V
Pounds	1030	1080	1055	1105

VAH2048	Base	w/Greencube	460V	w/GreenCube & 460V
Pounds	1045	1095	1070	1120

VAH2060	Base	w/Greencube	460V	w/GreenCube & 460V
Pounds	1060	1110	1085	1135

Air Filters

	Qty per unit	Size	Type	MERV ¹ Rating
Return Air Filter	2	Consult Factory	Pleated, disposable	8 ²
Fresh Air Ventilation Filter	1	Consult Factory	Fiberglass, disposable	N/A
Exhaust Air Ventilation Filter	1	Consult Factory	Fiberglass, disposable	N/A

¹MERV = Minimum Efficiency Reporting Value

²Optional filters are available with MERV ratings of 11 and 13.

DIMENSIONAL DATA FOR VDH2024/2036/2040 & VAH2030/2048/2060

ENGINEERING REVISION "B"

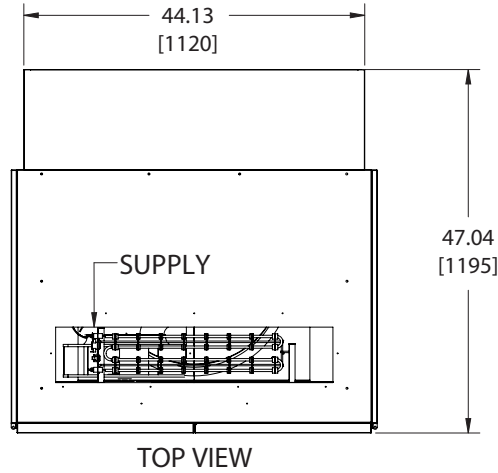

NOTE:
44" X 44" WALL SLEEVE IS AN
EXAMPLE OF A COMMON SIZE.
ACTUAL DIMENSIONS MAY VARY
DEPENDING ON PROJECT
SPECIFICATIONS.

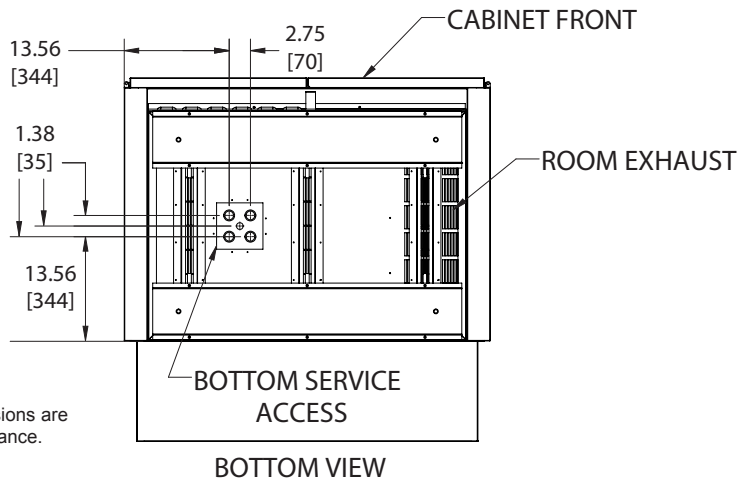
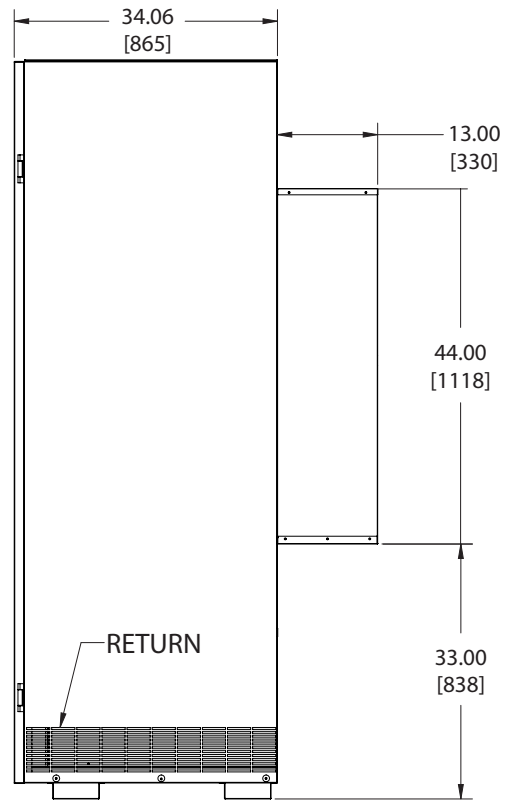
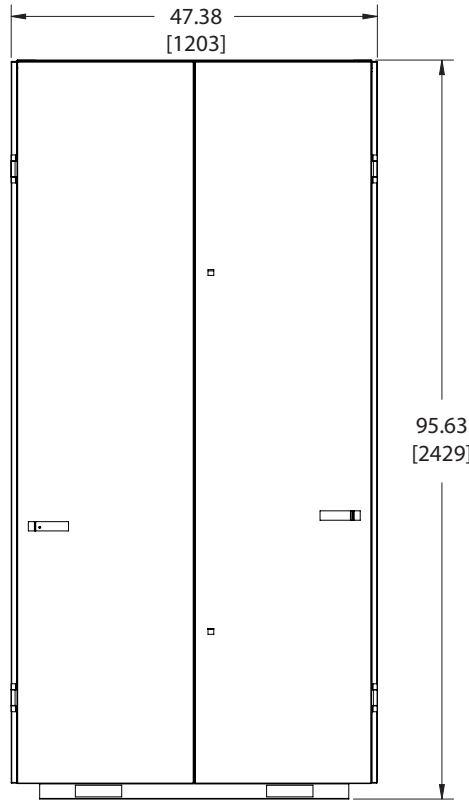
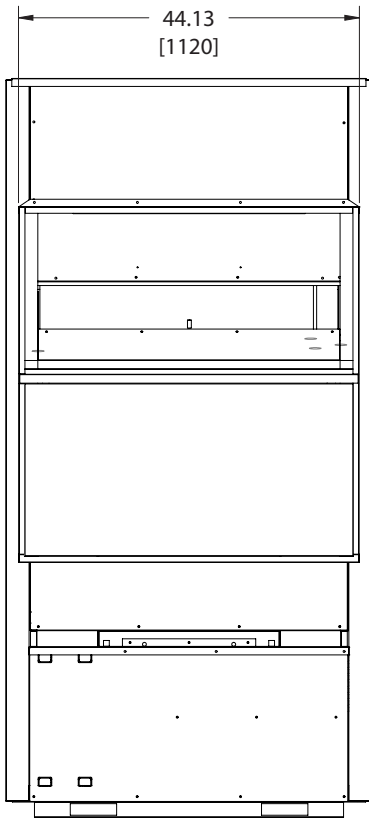

Note: All overall outside dimensions are given with +/- .250" (6mm) tolerance.

DIMENSIONAL DATA FOR VDH2024/2036/2040 & VAH2030/2048/2060 w/SIDE PANELS REMOVED

ENGINEERING REVISION "B"

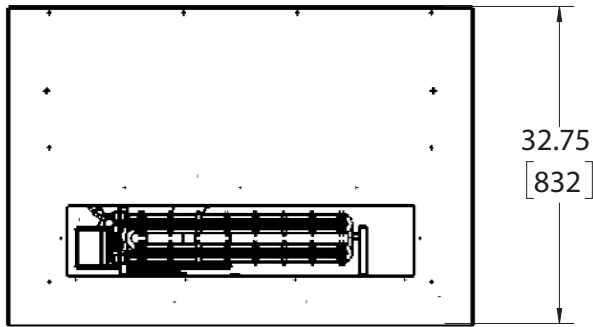

TOP VIEW

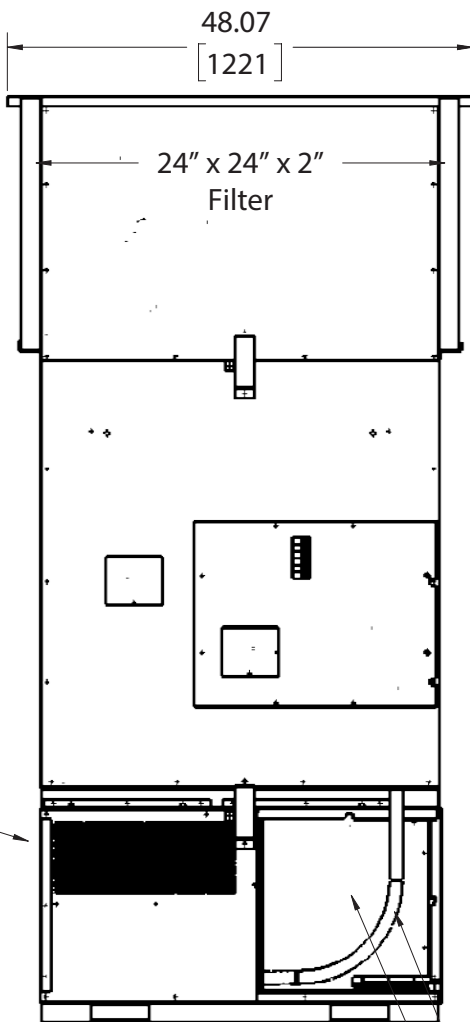

INTAKE MOTOR
LOCATED
BEHIND THIS
PANEL

FRONT VIEW

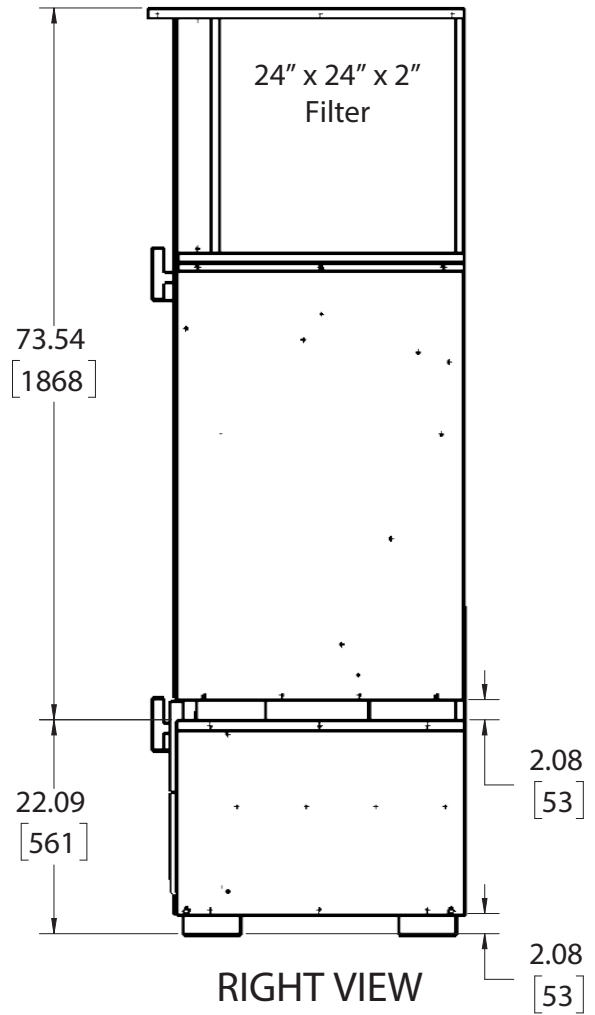

RIGHT VIEW

CONDENSATE DRAIN
GREENCUBE (IF REQUESTED),
FRESH AIR FILTERS, AND EXHAUST MOTOR
LOCATED BEHIND THIS PANEL

Note: All overall outside dimensions are given with +/- .250" (6mm) tolerance.

DIMENSIONAL DATA FOR VDH2024/2036/2040 & VAH2030/2048/2060 HOT WATER PLENUM

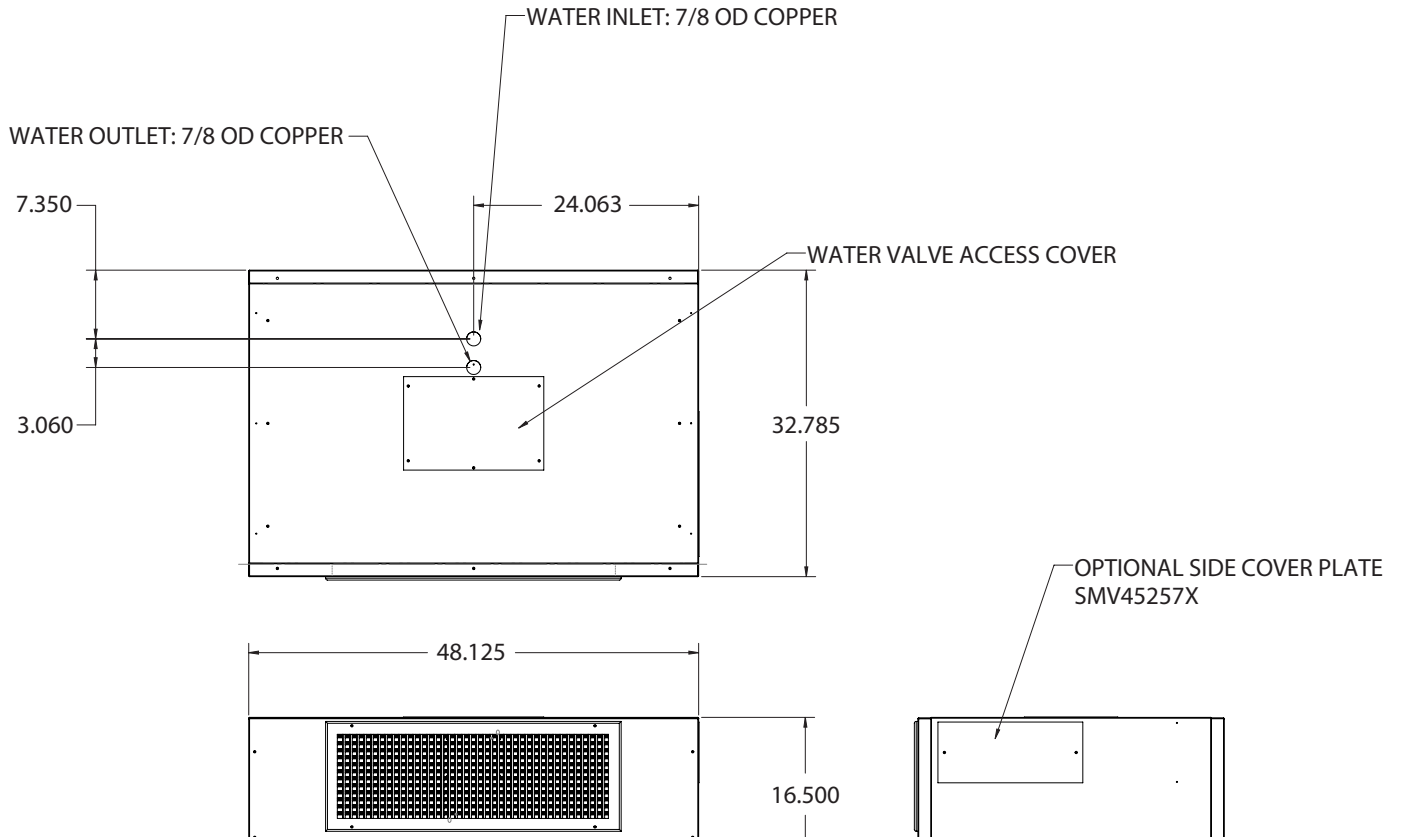

DIMENSIONAL DATA FOR VDH2024/2036/2040 & VAH2030/2048/2060 OUTDOOR LOUVER

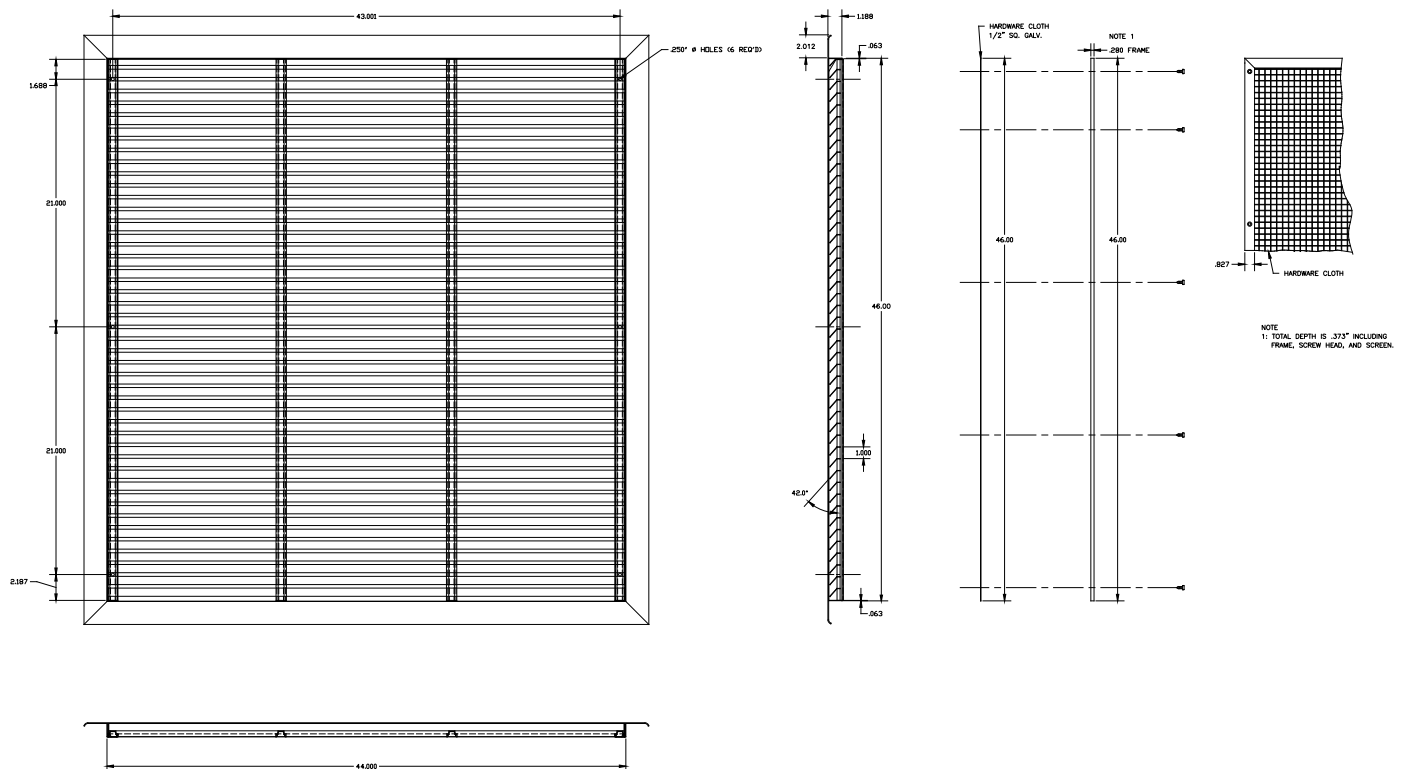

TYPICAL INSTALLATION DETAIL

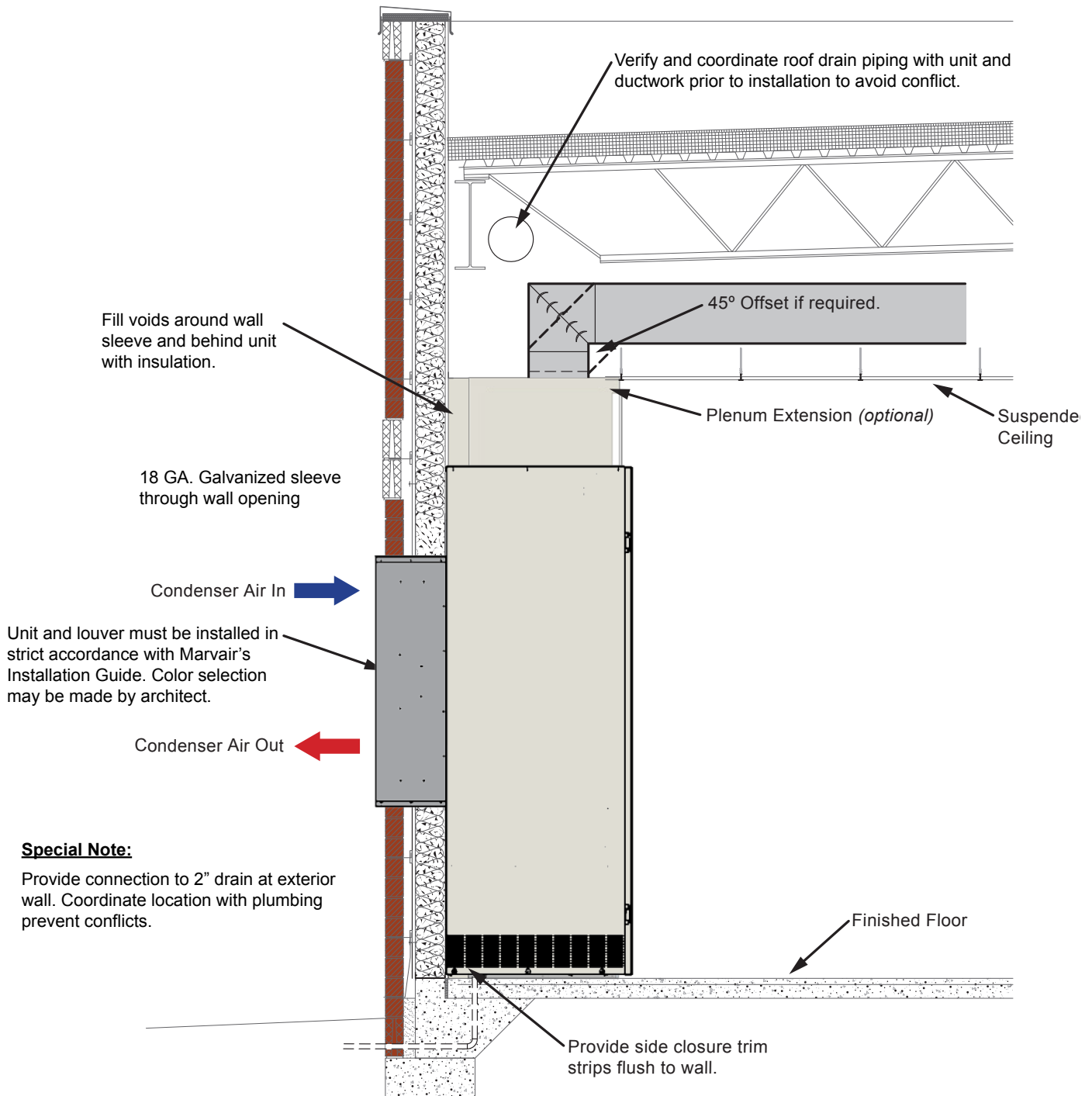

Note:

1. Coordinate installation of unit with general contractor for a complete and airtight installation. Caulk unit casing to wall.
2. Installation of the louver must be performed by the mechanical contractor and caulked by the general contractor
3. Provide blank off panel on rear of louver to seal off unused portion of louver.

WALL MOUNTED LOUVER DETAIL

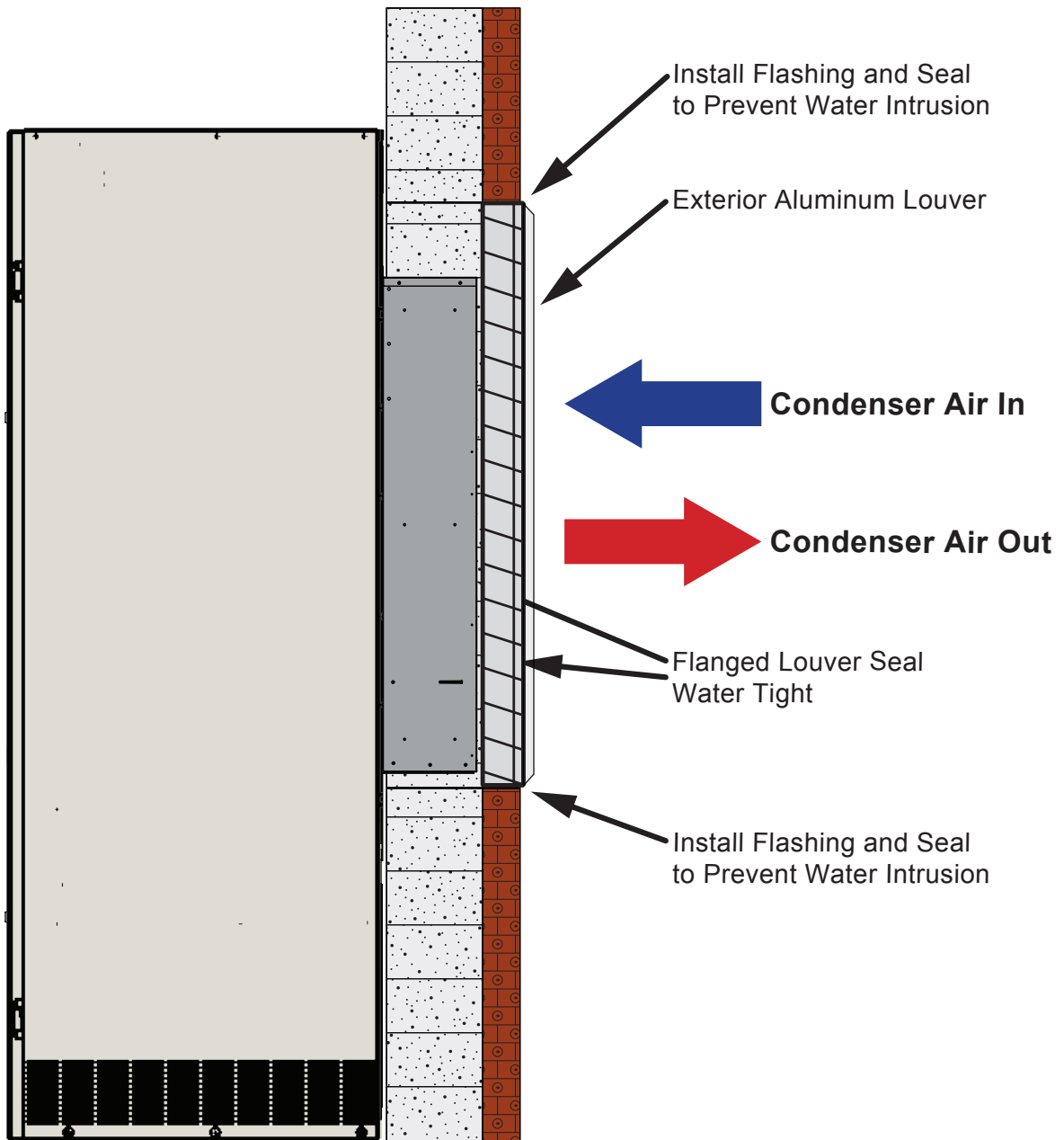

Please consult the Marvair® website at www.marvair.com for the latest product literature. Detailed dimensional data is available upon request. A complete warranty statement can be found in each product's Installation/Operation Manual, on our website or by contacting Marvair at 229-273-3636. As part of the Marvair continuous improvement program, specifications are subject to change without notice.



Marvair[®]
An ACS Brand

P.O. Box 400 • Cordele, GA 31010
156 Seedling Drive • Cordele, GA 31015
Ph: 229-273-3636 • Fax: 229-273-5154
Email: marvair@airxcs.com • Internet: www.marvair.com

Designed,
Engineered
&
Assembled
In the USA