

Controller for Redundant Air Conditioner Systems

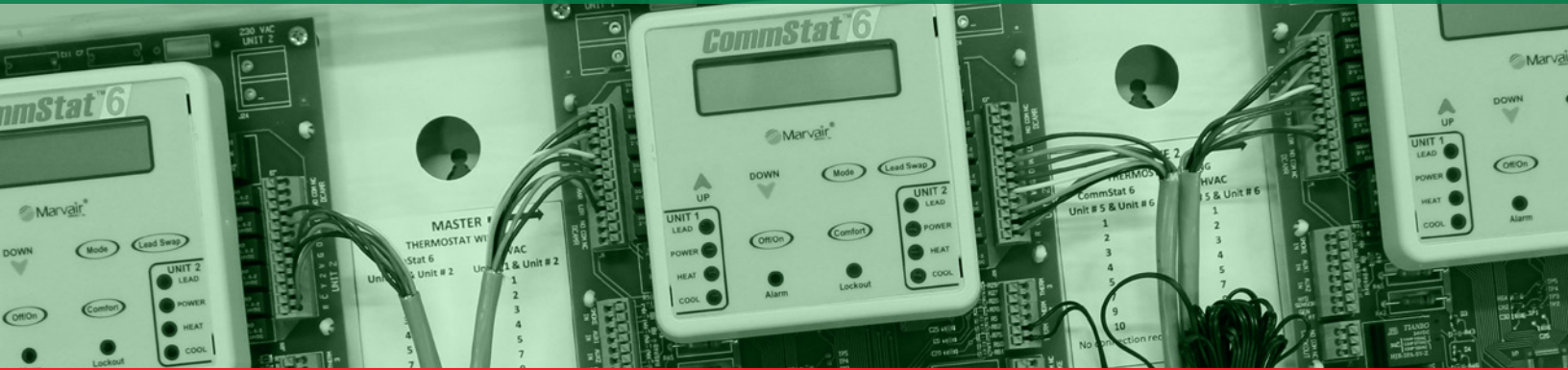

GENERAL DESCRIPTION

The CommStat[™] 6 HVAC controller is designed for controlling up to six redundant HVAC units (non Heat Pump) in an E-House or telecommunication shelter and is available in three configurations.

- CommStat 6 2/4** - Controls up to **two** single or 2-Stage HVAC units (non Heat Pump) (4 Stages max.) Marvair Part Number:..... 70705
- CommStat 6 4/8** - Controls up to **four** single or 2-Stage HVAC units (non Heat Pump) (8 Stages max.) Marvair Part Number:..... S/12087-04
- CommStat 6 6/12** - Controls up to **six** single or 2-Stage HVAC units (non Heat Pump) (12 Stages max.) Marvair Part Number:..... S/12087-06

In addition to the control of the air conditioners, the CommStat 6 controller has multiple configurable outputs for remote alarms or notification.

The CommStat 6 controller is factory programmed with standard industry set points, but can be configured on site. Settings are retained indefinitely in the event of a power loss.

► Master/Slave Modules

The CommStat 6 controller consists of multiple modules housed in a durable and attractive enclosure. Each module consists of a keypad/display and PC board. The CommStat 6 4/8 controller has one Master and one Slave module. The 6/12 version has one Master module and two Slave modules. Any settings to the Master module immediately take effect on the Slave module(s).

The CommStat 6 controller connects to each air conditioner with standard low voltage thermostat conductors.

► Ease of Control and Configuration

A large, backlit LCD displays show the status of the system and provides a convenient user interface. Status LEDs indicate Heat, Cool, Power and the Lead Unit. When a fault is detected, an alarm LED illuminates and the LCD screen displays the fault. If multiple faults are detected, the display will scroll the faults across the screen.

The CommStat 6 controller is easily configured with four buttons. A Comfort button changes the temperature in the shelter for 90 minutes. After 90 minutes, the temperature reverts back to the programmed set points. A lead swap button alternates the lead and lag unit, allowing service techs to quickly check the operation of each unit.

For security, the keypad can be locked out to prevent unwanted changes to the set points. English, Spanish or French is selectable as the language shown on the display. °F or °C is selectable.

► RoHS Compliant

The CommStat 6 controller contains no hazardous materials and is RoHS compliant.



CommStat 6 6/12 Controller

Designed,
Engineered
&
Assembled
in the USA

Features and Benefits

Programmable Solid State Controller

- *Balanced Use of Conditioning Equipment*
- *Sequence the Operation of Six Air Conditioners*
- *Ensures Maximum Efficiency*
- *Independent Economizer Control*

Alarms and Lockouts

- *High Pressure Alarm/Lockout*
- *Low Pressure Alarm/Lockout*
- *Low Temperature*
- *High Temperature Stage 1*
- *High Temperature Stage 2*
- *Smoke*
- *Low Voltage Loss*

Dry Contact Alarm Outputs

- *Notification of HVAC Unit Failure*
- *High/Low Pressure Lockout*
- *Low Temperature*
- *High Temperature Stage 1*
- *High Temperature Stage 2*
- *Smoke*
- *Low Voltage Loss*

SPECIFICATIONS/FEATURES

► Thermostat

- Cooling Set Point: 65°F through 95°F (18°C through 35°C) in 1° increments.
- Heating Set Point: 50°F through 80°F (10°C through 27°C) in 1° increments.

► Differential

- All stages ON differential: 1°F through 5°F (1° through 3°C) in 1° increments.
- All stages OFF differential: 1°F through 5°F (1° through 3°C) in 1° increments. The 2nd stage differential is referenced to the 1st stage differential and the outputs will stage off as each stage's differential is satisfied.
- Changeover Differential between cooling and heating: Minimum of 3°F (2°C).

► Control Voltage

- The CommStat 6 controller is powered by a nominal 24 VAC and optional user provided backup 24 VDC or 48 VDC power supply. Should AC power be lost, the display, user interface and the alarm outputs remain functional. System outputs (Y, G, W, O and the Mixed Air Relay) will not be functional when 24 VAC is not present. If the control voltage is not present, the Low Voltage Loss alarm relay is energized.

► Operating Range: -40°F through 150°F (-40°C through 66°C)

► Minimum Voltage: 18 VAC

► Maximum Voltage: 30 VAC

► Ease of Installation

- Wiring connection insensitive to phasing of the units.
- Easy terminal connections for thermostat wire.
- Remote temperature sensors insure accurate temperature readings in the shelter.
- Easy attachment to the wall.

► Lead/Lag Operation

- The CommStat 6 controller automatically alternates the lead unit for each cooling cycle.

► Alarms

Dry contacts can be used for remote alarm or notification. Relays can be wired Normally Open (NO) or Normally Closed (NC). Most alarm relays can be reset by turning the CommStat 6 OFF and then ON OR the UP and DOWN buttons are held simultaneously for 4 seconds. Alarms can be reset provided there is no longer an input from the smoke detector. All alarms are functional when 24 VAC is applied to the board. If 24 VAC is not present, no alarms will be displayed unless DC power is present. If DC power is supplied to the board, the display is operational.

- **Low (Control) Voltage** – activated if control voltage is not present.
- **Lockout** – activated if any air conditioner is off due to either high or low refrigerant pressure lockout. If all the air conditioners are locked out, the Mixed Air Relay (MAR) will be activated on each of the air conditioners. This air conditioner will go into the Ventilation mode, provided there is a call for cooling. (Note: The Mixed Air Relay is only on units with an economizer) If desired, the lockout alarm can be disabled by the user in the Configuration Set-up.
- **Low Building Temperature Alarm** – Activated if the temperature in the building drops to the selected temperature. If the low building temperature alarm is activated, the LCD displays, "Low Building Temperature".
- **First Stage High Building Temperature Warning** – If the set point temperature is reached, the display will show, "First Stage High Building Temperature" on the LCD display.
- **Second Stage High Building Temperature Alarm** - Activated if the set point temperature is reached, the display will show, "Second Stage High Building Temperature" on the LCD display.
- **Smoke Alarm** – the contacts will be energized when the smoke detector inputs receive a signal from an external detector. All air conditioners are immediately shut down. A physical reset is required to clear the alarm in the manual mode. If auto reset has been selected, the alarm will reset after the user specified time (3-10 minutes).
- **AUX1 and AUX2** – Two auxiliary dry contact outputs that can be energized based upon AUX1 and AUX2 inputs. See AUX1-IN/AUX2 INPUT on page 4 for complete description.

COMMSTAT™ 6 CONTROLLER LEAD/LAG INPUTS

1. Input Power

The R and C terminals are the input power terminals for each respective air conditioner.

2. Control Voltage (24 VAC)

The CommStat™ 6 controller is powered by 24 VAC or with a user provided 24 VDC or 48 VDC power supply. Should AC power be lost, the display, user interface and alarm outputs of the CommStat 6 will still be functional. However, the system outputs of the CommStat 6 (Y, G, W, O, and MAR) will not be functional when 24 VAC is not present.

3. Temperature Sensors

The CommStat 6 controller uses remote temperature sensor(s) to measure the temperature in the shelter and determine when the system is calling for heating or cooling. Up to three sensors can be connected to each CommStat 6 controller. There are two options for the sensors. If **No** (the default setting) is selected and multiple sensors are being used, the temperatures will be averaged. If **Yes** is selected and multiple sensors are being used, the sensor with the highest reading will be used for cooling operation and the one with the lowest reading will be used for heating. When multiple sensors are being used and there is a temperature differential greater than or equal to 5°F (4°C) between the sensors, the CommStat 6 lead/lag controller will energize the indoor blowers (G) on all connected units.

Screen #20 in the Configuration Mode allows the user to determine how the temperature sensors will be configured.

4. Smoke Detector

The smoke detector **input terminals** determine when there is a signal from an external smoke detector. They can be configured for either a **Normally Open** (N.O.) or **Normally Closed** (N.C.) smoke signal in Configuration screen # 18. During a smoke fault condition, all AC units will be turned off.

The smoke alarm relay reset has two selections -**Manual** and **Auto** (default). If **Manual** is selected, a physical reset of the fault is required by holding the Up and Down buttons for 4 seconds. Cycling power will not reset a smoke fault if **Manual** is selected.

If **Auto** is selected the alarm will reset after an adjustable time delay of 3-10 minutes. The default is 5 minutes. Screen #17 in the Configuration Mode allows the user to determine how the smoke alarm relay reset will be configured.

Note: The Smoke Detector input is for DRY CONTACTS ONLY, applying voltage to the smoke alarm input will damage the controller.

5. Hydrogen Detector

The hydrogen detector input terminals will determine when there is a 24 VAC signal from an external hydrogen detector. The CommStat 6 controller will switch the lead unit to Emergency Ventilation mode (air conditioners with economizers only) when high hydrogen levels are detected. It will switch back to normal air conditioning mode once the hydrogen levels are acceptable and the 24 VAC signal is removed from the hydrogen detector input terminals.

6. Generator Relay

The generator input will monitor for a 24 VAC signal which will be used to determine when the CommStat 6 controller is operating on generator power. When 24 VAC is recognized at the generator relay input, the CommStat 6 controller will only operate the units selected by the user in screen # 16 of the Configuration Menu. The options are:

1. to run only the lead unit (default),
2. the lead unit and one lag unit,
3. the lead unit and two lag units, or
4. the lead unit and three lag units.
5. the lead unit and four lag units.
6. the lead unit and five lag units.

Note: in the Generator Mode, only the Lead unit will operate in the Mechanical Cooling Mode; the economizer will not operate in the Generator Mode. However, if a hydrogen fault occurs during the Generator Mode, the Mechanical Cooling will be terminated on the Lead unit and the Lag unit will operate in the Economizer Mode. **"*GEN RUN*"** is displayed on the screen whenever the generator is running.

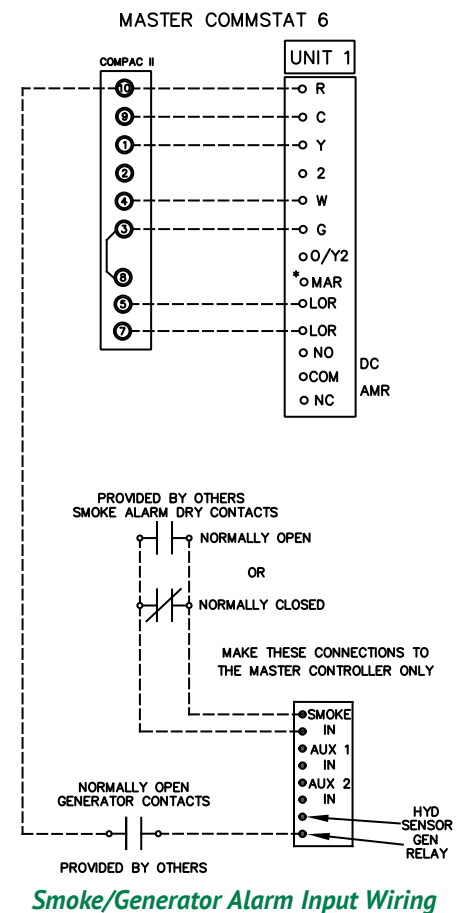

7. Economizer Mode Status Monitoring

Terminal 2 in the air conditioner is monitored for a 24 VAC signal. When Terminal 2 has 24 VAC present, mechanical cooling will be energized and the cooling LED will be lit. When 24 VAC is not present at Terminal 2. When the CommStat 6 is configured for an economizer, AUX 1 and AUX2 are used for economizer status monitoring.

Note: If setting #19 is set to 1, these inputs are used to monitor whether the units are in economizer mode. When a terminal has 24 VAC present, the unit will be in the cooling mode and the cooling LED will be energized. When 24 VAC is not present at the terminal, the unit will be in economizer mode and this status will be annunciated on the LCD display.

Note: See the Economizer Operational Modes on page 9. When set to economizer configuration 2 in screen #19, the AUX1 and AUX2 inputs are used for economizer mode status monitoring. See wiring diagram on page 7.

8. AUX1-IN/AUX2

The CommStat 6 controller has the option for two, dry contact, auxiliary outputs that will energize based on the AUX1 and AUX2 inputs. Each AUX input can be configured to look for a normally open (NO) or normally closed (NC) signal in Configuration Mode, screens # 21 and # 22. Each screen will allow the user the option of **NO**, **NC**, or **OFF** to disable the feature. Note: AUX1 and AUX2 are not available when Economizer units are selected in screen 19. AUX1 and AUX2 are independent from the operation of the board and the air conditioner.

9. Lockout Relay (LOR)

The CommStat 6 controller has a lockout relay input (LOR) and will provide a Normally Open (NO) or Normally Closed (NC) output in accordance to this input. This feature is enabled in the Configuration Mode, screen #9 by either selecting 0,1,2 or 3 (2 default). If 0 or 1 is selected, the control will turn the lockout relay output off and annunciate which unit is locked out on the LCD display. If 2 or 3 is selected, the control will turn the lockout relay output on, energize the lockout relay output (NO or NC), and annunciate which unit is locked out on the LCD display. If all the units are locked out, the mixed air relay will be activated on each unit to provide emergency ventilation, provided there is a call for cooling. The mixed air relay and emergency ventilation are only available on units with economizers.

Cycling power at the locked out air conditioner will reset the Lockout fault. A physical reset of the fault will be required by pressing the Up and Down buttons for 4 seconds.

COMMSTAT 6 LEAD/LAG CONTROLLER OUTPUT

(Refer to the CommStat 6 Controller Line Voltage Connection Schematics beginning on page 8)

1. Y or 1

The Y or 1 output energizes the compressor when the economizer is not selected. Upon a call for cooling, the Y (1) and O terminals are energized. On a call for 1st stage heating, the Y(1) output will be energized. There is a minimum compressor time off delay of 3 minutes for the lead unit and 4 minutes for the lag unit.

2. G or 3

The G or 3 output terminal energizes the indoor fan during either heating or cooling.

3. W or 4

The W or 4 output terminal energizes the electric heat.

4. O/Y2, A/C with 2-Stage Compressor or Dual Compressor HVAC Units (non Heat Pump)

Terminal 2 will provide a 24 VAC signal to force mechanical cooling. When the 1st stage high temperature alarm set-point is reached terminal 2 will be energized. Each connected unit will output terminal 2 based on the staging temperature differential or staging timer setting. The 2 output will de-energize when the 1st stage cooling set-point plus the OFF differential is reached. When setting #19 is set to No, output terminal 2 has no function. The Y or 1 output will also remain energized until the 1st stage cooling set-point plus the OFF differential is reached..

5. Lockout Alarm

When enabled in screen #9 of the Configuration Menu, the CommStat 6 controller monitors the Lockout Relay (LOR) input for a contact closure. If there is a contact closure between the LOR terminals, the control will turn off all outputs, energize the NO or NC contacts, and display which unit is locked out on the LCD display. The default setting in the configuration is 2. If all of the connected units are locked out, the Mixed Air Relay (MAR) will be activated on each of the connected units and the units will go into Emergency Ventilation mode. Cycling power will reset the Lockout Alarm.

6. Low (Control) Voltage Loss Alarm

The low voltage loss alarm relay provides a dry contact closure if control voltage is not present.

7. Low Building Temperature Alarm

The Low Building Temperature Alarm has an adjustable temperature range of 32°F thru 65°F (0°C thru 18.3°C) that may be adjusted in screen #7 of the configuration menu. If the temperature drops to this setting, all outputs will be turned off, the LCD display will annunciate Low Building Temperature and the Low Building Temperature alarm output relay will be activated. There is a 2°F (1°C) differential for this alarm to reset.

8. First Stage High Building Temperature Warning

The set point temperature is adjustable from 70°F thru 140°F (21°C thru 60°C). If this set point is reached, the control will display a First Stage High Building Temperature warning on the LCD display. The default setting for this is 85°F (29°C). There is a 2°F (1°C) differential for this alarm to reset. The first stage high temperature warning set point is adjustable in screen #5 the Configuration Menu.

9. Second Stage High Building Temperature Alarm

This set point is adjustable from 75°F thru 145°F (24°C thru 63°C). If this set point is reached, the control will display a Second Stage High Building Temperature alarm on the LCD display. There is a 2°F (1°C) differential for this alarm to reset. The temperature set point for the second stage high temperature alarm is adjustable in screen #6 of the Configuration Menu. The default setting for this is 90°F (32°C).

10. Smoke alarm

The smoke alarm is energized when the smoke detector inputs sense a smoke fault condition. All outputs are off and the smoke alarm relay is energized during a smoke fault. This is a dry contact output that can be configured for NO or NC (default) operation in setting #18 of the configuration menu.

The smoke alarm has two selections -**Manual** and **Auto** (default). The smoke alarm relay can be manually reset by either cycling the 24 VAC power or clearing the fault and holding the UP & DOWN buttons for 4 seconds.

If **Auto** is selected the alarm will reset after an adjustable time delay of 3-10 minutes, with a default time of 5 minutes. Screen #17 in the Configuration Mode allows the user to determine how the smoke alarm relay reset will be configured.

11. Mixed Air Relay (MAR)

The MAR output will be energized by the CommStat 6 controller when all connected units have locked out. This is referred to as the Emergency Ventilation Mode. The mixed air relay and Emergency ventilation are only available on units with economizers.

12. DC Air Mover Relay (AMR)

The DC Air Mover Relay has a dry contact output and is energized in the Emergency Ventilation Mode.

13. AUX1 and AUX2

The CommStat 6 controller has the option for two, dry contact, auxiliary outputs that are energized based on the AUX1 and AUX2 inputs. Each AUX input can be configured to look for a normally open (NO) or normally closed (NC) signal in configuration screens #21 and #22. Each configuration screen allows the user the option of **NO**, **NC**, or **OFF** (default) to disable the feature. The AUX1 and AUX2 outputs provide a NO, NC, and COM terminal. Note: AUX1 and AUX2 are not available when the economizer units are selected in screen 19. (See configuration menu on page 15).

Output	Type	Nominal	Minimum	Maximum
Y or 1	Relay	24VAC	18VAC	30VAC
G or 3	Relay	24VAC	18VAC	30VAC
W or 4	Relay	24VAC	18VAC	30VAC
O	Relay	24VAC	18VAC	30VAC
Lockout Alarm	3PDT	N/A	N/A	10 Amps @ 120VAC
Low (Control) Voltage Loss Alarm	3PDT	N/A	N/A	10 Amps @ 120VAC
Low Building Temperature Alarm	Relay	N/A	N/A	10 Amps @ 120VAC
First Stage High Building Temperature Warning	Relay	N/A	N/A	10 Amps @ 120VAC
Second Stage High Building Temperature Alarm	Relay	N/A	N/A	10 Amps @ 120VAC (Isolated Dry Contacts)
Smoke Alarm	Relay	N/A	N/A	10 Amps @ 120VAC
Mixed Air Relay (MAR)	Relay	24VAC	18VAC	30VAC
DC Air Mover Relay (AMR)	Relay	N/A	N/A	10 Amps @ 120VAC
AUX1 / AUX2 (Auxiliary Contacts) See Setting #19	Relay	N/A	N/A	10 Amps @ 120VAC

Table 1. Contact Ratings

IMPORTANT SAFETY PRECAUTIONS

WARNING

ALWAYS TURN OFF POWER AT THE MAIN POWER SUPPLY BEFORE INSTALLING, CLEANING, OR REMOVING CONTROLLER.

WARNING

DO NOT USE BATTERY OPERATED OR ELECTRIC TOOLS TO TIGHTEN SCREWS ON COVER OF THE COMMSTAT 6 CONTROLLER.

- This thermostat is for 24 VAC applications only; do not use on voltages over 30 VAC
- Do not short across terminals of system control to test operation; this will damage your thermostat and may void your warranty
- All wiring must conform to local and national electrical and building codes
- Use this thermostat only as described in this manual

TO INSTALL COMMSTAT 6 CONTROLLER

WARNING ELECTRICAL SHOCK HAZARD

TURN OFF POWER AT THE MAIN SERVICE PANEL BY REMOVING THE FUSE OR SWITCHING THE APPROPRIATE CIRCUIT BREAKER TO THE OFF POSITION BEFORE REMOVING THE EXISTING THERMOSTAT.

IMPORTANT

COMMSTAT 6 CONTROLLER INSTALLATION MUST CONFORM TO LOCAL AND NATIONAL BUILDING AND ELECTRICAL CODES AND ORDINANCES.

Note: Mount the CommStat 6 controller about five feet above the floor. Do not mount the CommStat 6 controller in direct sunlight, behind a door, or in an area affected by a vent or duct. The CommStat 6 controller is designed for interior use only.

1. Turn off power to the heating and cooling system by removing the fuse or switching off the appropriate circuit breaker.
2. Put controller against the wall where you plan to mount it (Be sure wires will feed through the wire opening in the base of the CommStat 6 controller).
3. Mark the placement of the mounting holes.
4. Using a drill bit, drill holes in the places you have marked for mounting.
5. Align the CommStat 6 controller with mounting holes and feed the control wires through wire opening.
6. Use screws to mount the CommStat 6 controller to wall.
7. Insert stripped, labeled wires in matching wire terminals. See Wiring Diagrams. **CAUTION!:** Be sure exposed portion of wires do not touch other wires.
8. Gently tug wire to be sure of proper connection. Double check that each wire is connected to the proper terminal.
9. Seal hole for wires behind the CommStat 6 controller with non-flammable insulation or putty.
10. Replace cover on CommStat 6 controller.
11. Turn on power to the system at the main service panel.
12. Test CommStat 6 controller operation as described in “Testing the CommStat 6 Controller”.

REMOTE SENSOR INSTALLATION

(Refer to the *CommStat 6 Controller Remote Sensor Connections Schematic on page 7*)

1. Remove cover from remote sensor(s) housing.
2. Select an appropriate location for mounting the remote sensor(s).
3. Mount remote sensor(s) unit using hardware provided.
4. Install two wires between remote sensor(s) and CommStat 6 controller using shielded cable that is adequately grounded.
 - Wire 1 should run between an unused THERM terminal on the CommStat 6 controller and the S1 terminal on the remote sensor
 - Wire 2 should run between an unused THERM terminal on the CommStat 6 controller and the S2 terminal on the remote sensor

OPTIONAL ACCESSORIES

- Onboard Sensor (includes 24 ft. / 732 cm cable) P/N 80503
- Expansion Cable..... P/N 80515
To be used when two CommStat 6 controllers are installed in a Master/Slave configuration.
- Remote sensor with 25 ft. (762 cm) cable..... P/N 80503

COMMSTAT 6 CONTROLLER REMOTE SENSOR CONNECTIONS SCHEMATIC

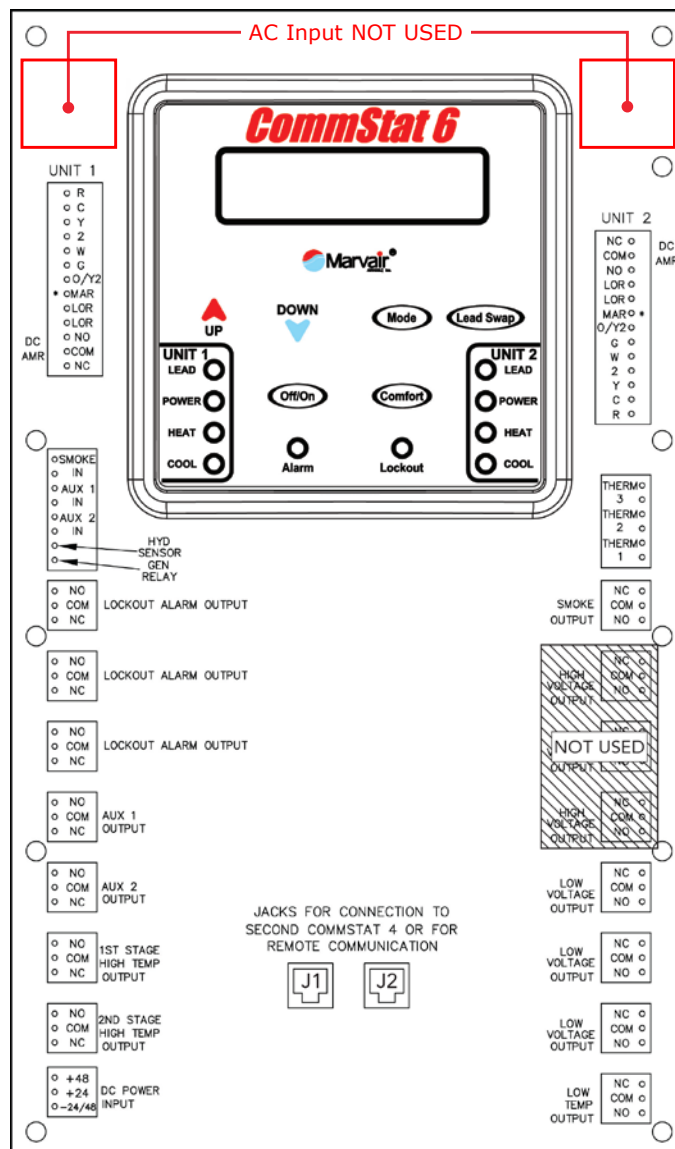

COMMSTAT 6 2/4 CONTROLLER LOW VOLTAGE CONNECTION SCHEMATIC

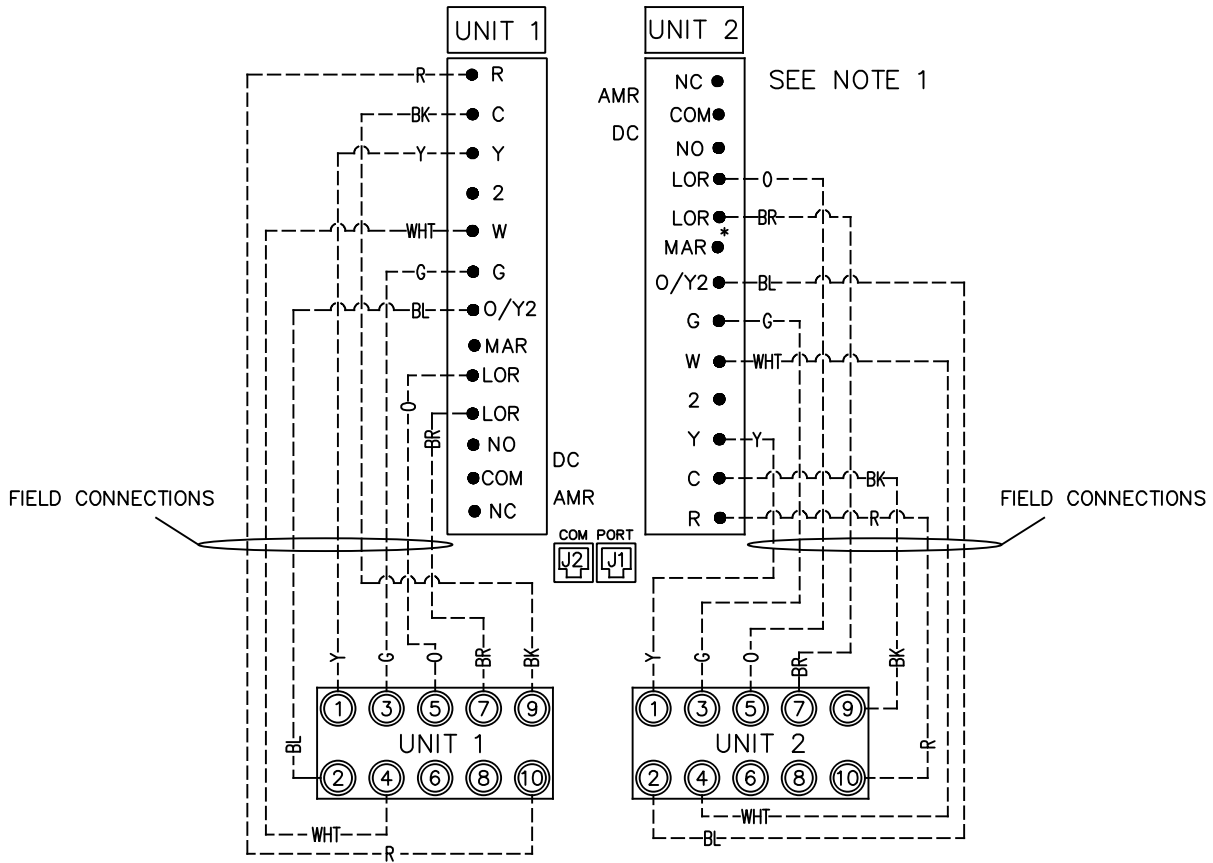

ADDITIONAL FIELD CONNECTIONS FOR SYSTEMS WITH ECONOMIZER (SEE NOTE 2)
COMMSTAT 6 MASTER

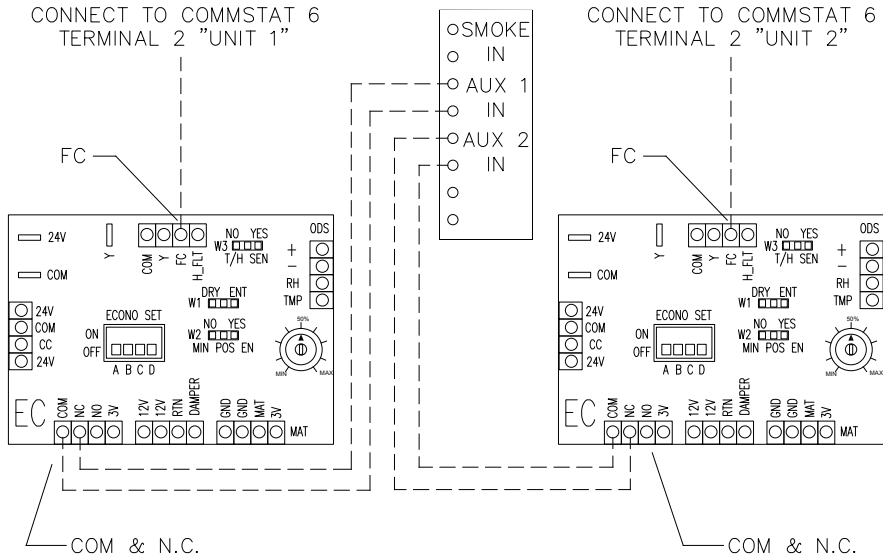

Note: For immediate shutdown of the HVAC unit(s) upon a signal from smoke alarm, the jumper between terminals 8 and 10 in the HVAC unit(s) electrical panel must be removed and a jumper placed between terminals 8 and 3.

COMMSTAT 6 2/4 CONTROLLER DIMENSIONAL DRAWING

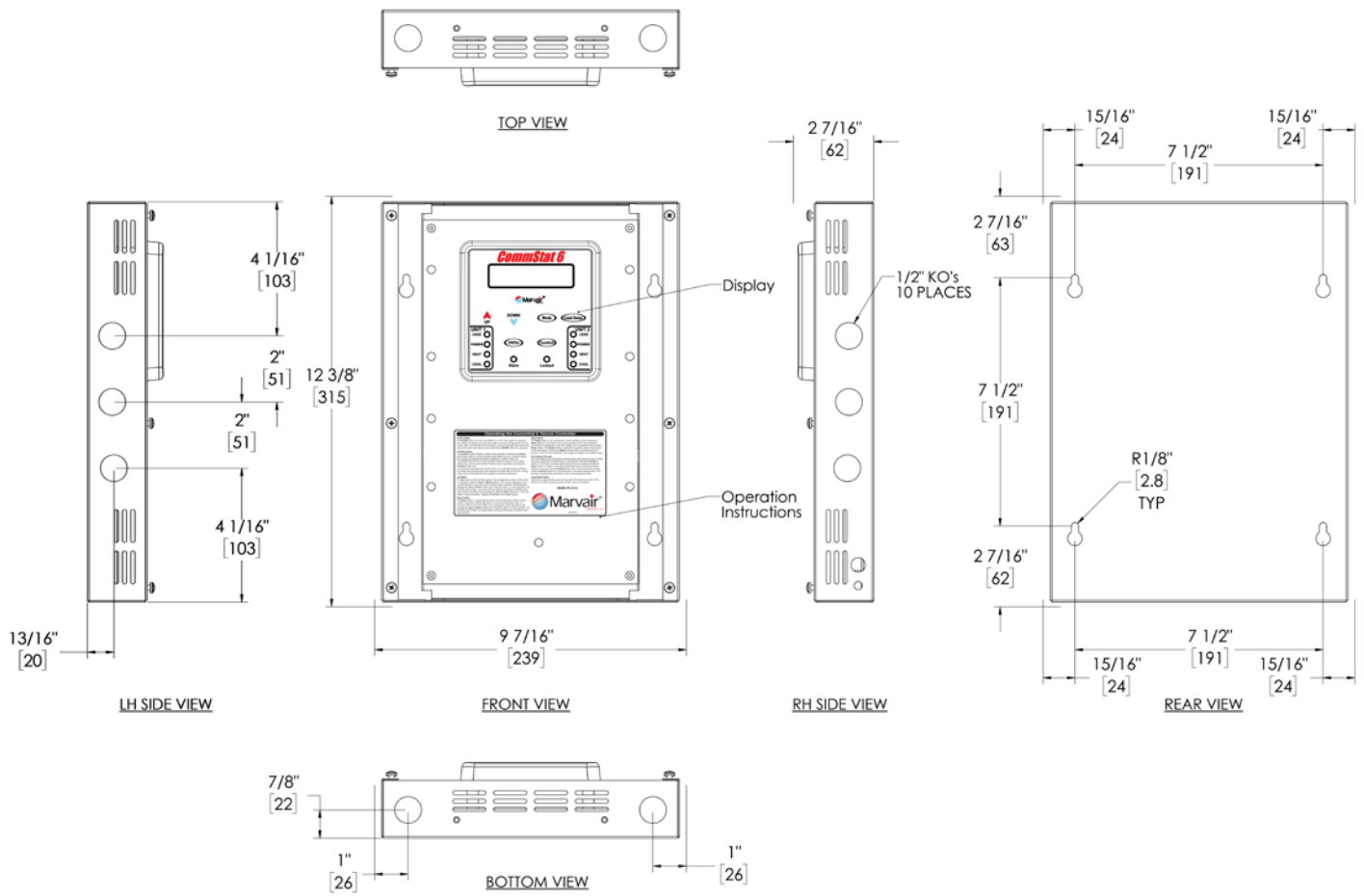

COMMSTAT 6 2/4 CONTROLLER OPERATION - TWO SINGLE COMPRESSOR UNITS

Set-Points Are Shown for Reference Only

Example Cooling Set-point 75°F (24°C) Setpoint is Adjustable

Example Cooling Differential 1°F (1°C) Setpoint is Adjustable

Indoor Temperature	Lead Unit	Lag Unit 1
75°F (24°C)	Fan Only	Off
76°F (24.5°C)	Cool	Off
77°F (25°C)	Cool	Cool

COMMSTAT 6 2/4 CONTROLLER OPERATION - TWO DUAL COMPRESSOR UNITS

Cooling Set-point 75°F (24°C) Setpoint is Adjustable

Cooling Differential 1°F (1°C) Setpoint is Adjustable

Indoor Temperature	Lead Unit	Lag Unit 1
75°F (24°C)	Fan Only	Off
76°F (24.5°C)	1st Stage Cool	Off
77°F (25°C)	2nd Stage Cool	Off
78°F (25.5°C)	2nd Stage Cool	1st Stage Cool
79°F (26°C)	2nd Stage Cool	2nd Stage Cool

COMMSTAT 6 4/8 CONTROLLER LOW VOLTAGE CONNECTION SCHEMATIC

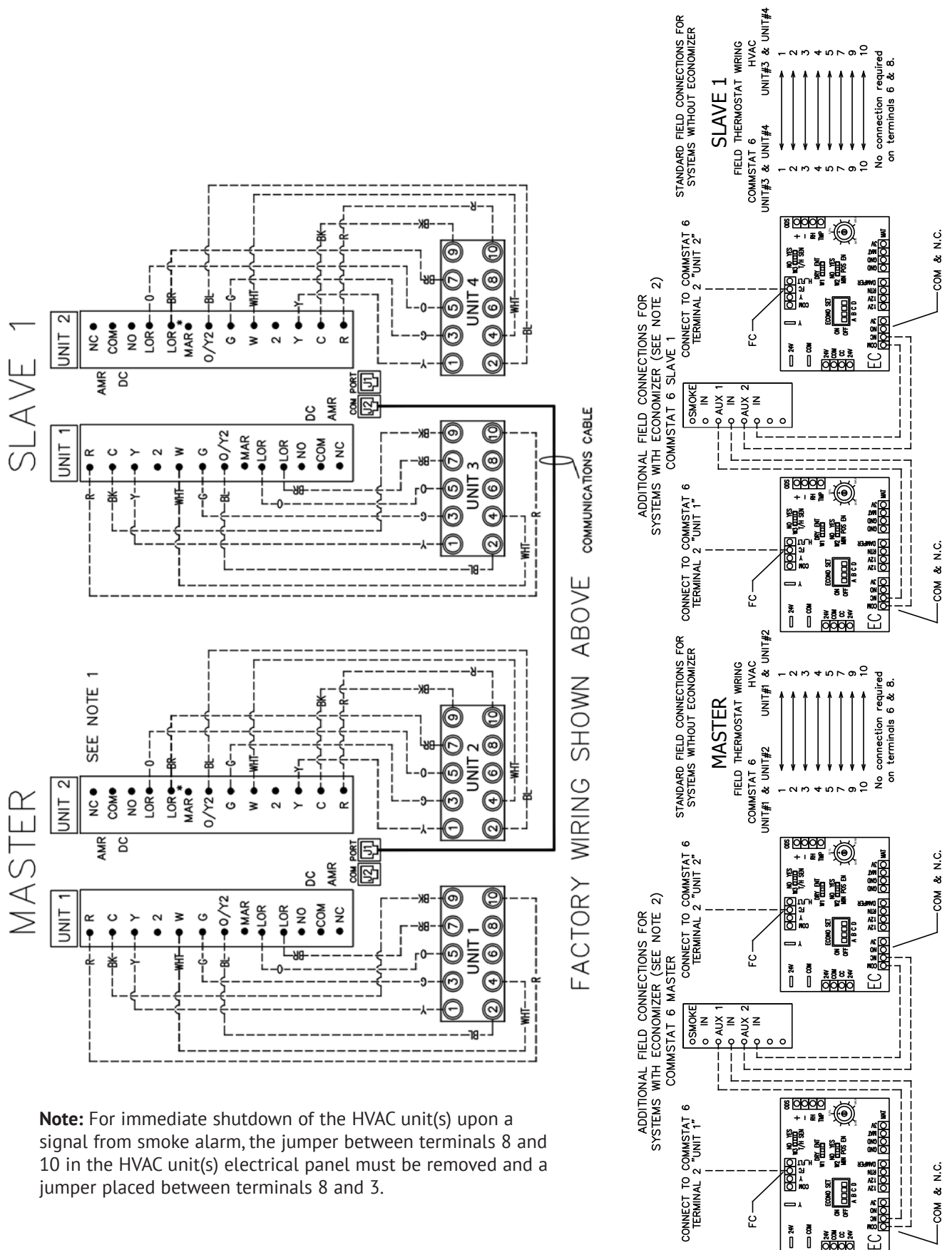

Note: For immediate shutdown of the HVAC unit(s) upon a signal from smoke alarm, the jumper between terminals 8 and 10 in the HVAC unit(s) electrical panel must be removed and a jumper placed between terminals 8 and 3.

COMMSTAT 6 4/8 CONTROLLER OPERATION - FOUR SINGLE COMPRESSOR UNITS

Set-Points Are Shown for Reference Only

Example Cooling Set-point 75°F (24°C) Setpoint is Adjustable

Example Cooling Differential 1°F (1°C) Setpoint is Adjustable

Indoor Temperature	Lead Unit	Lag Unit 1	Lag Unit 2	Lag Unit 3
75°F (24°C)	Fan Only	Off	Off	Off
76°F (24.5°C)	Cool	Off	Off	Off
77°F (25°C)	Cool	Cool	Off	Off
78°F (25.5°C)	Cool	Cool	Cool	Off
79°F (26°C)	Cool	Cool	Cool	Cool

COMMSTAT 6 4/8 CONTROLLER OPERATION - FOUR DUAL COMPRESSOR UNITS

Cooling Set-point 75°F (24°C) Setpoint is Adjustable

Cooling Differential 1°F (1°C) Setpoint is Adjustable

Indoor Temperature	Lead Unit	Lag Unit 1	Lag Unit 2	Lag Unit 3
75°F (24°C)	Fan Only	Off	Off	Off
76°F (24.5°C)	1st Stage Cool	Off	Off	Off
77°F (25°C)	2nd Stage Cool	Off	Off	Off
78°F (25.5°C)	2nd Stage Cool	1st Stage Cool	Off	Off
79°F (26°C)	2nd Stage Cool	2nd Stage Cool	Off	Off
80°F (26.5°C)	2nd Stage Cool	2nd Stage Cool	1st Stage Cool	Off
81°F (27°C)	2nd Stage Cool	2nd Stage Cool	2nd Stage Cool	Off
82°F (28°C)	2nd Stage Cool	2nd Stage Cool	2nd Stage Cool	1st Stage Cool
83°F (28.5°C)	2nd Stage Cool	2nd Stage Cool	2nd Stage Cool	2nd Stage Cool

COMMSTAT 6 6/12 CONTROLLER LOW VOLTAGE CONNECTION SCHEMATIC

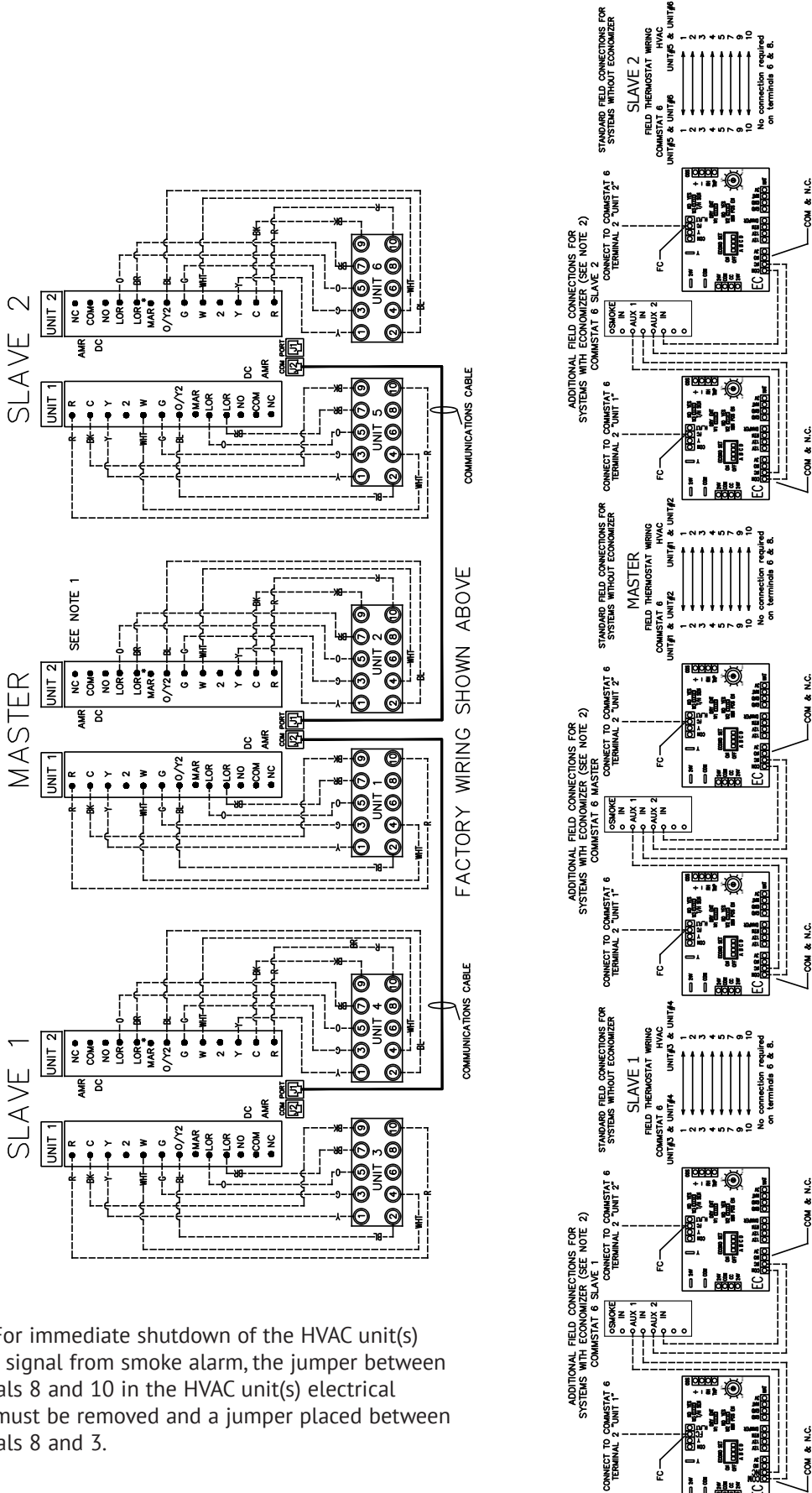

Note: For immediate shutdown of the HVAC unit(s) upon a signal from smoke alarm, the jumper between terminals 8 and 10 in the HVAC unit(s) electrical panel must be removed and a jumper placed between terminals 8 and 3.

COMMSTAT 6 6/12 CONTROLLER DIMENSIONAL DRAWING

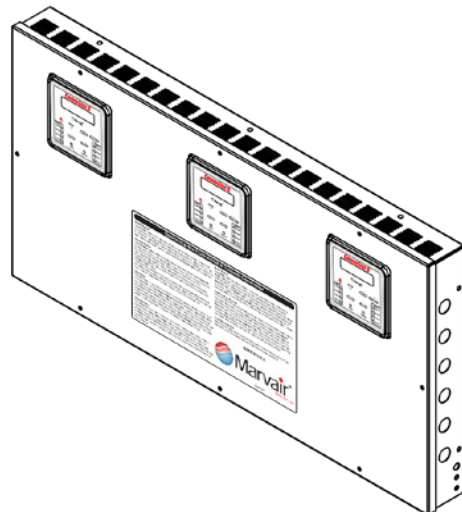
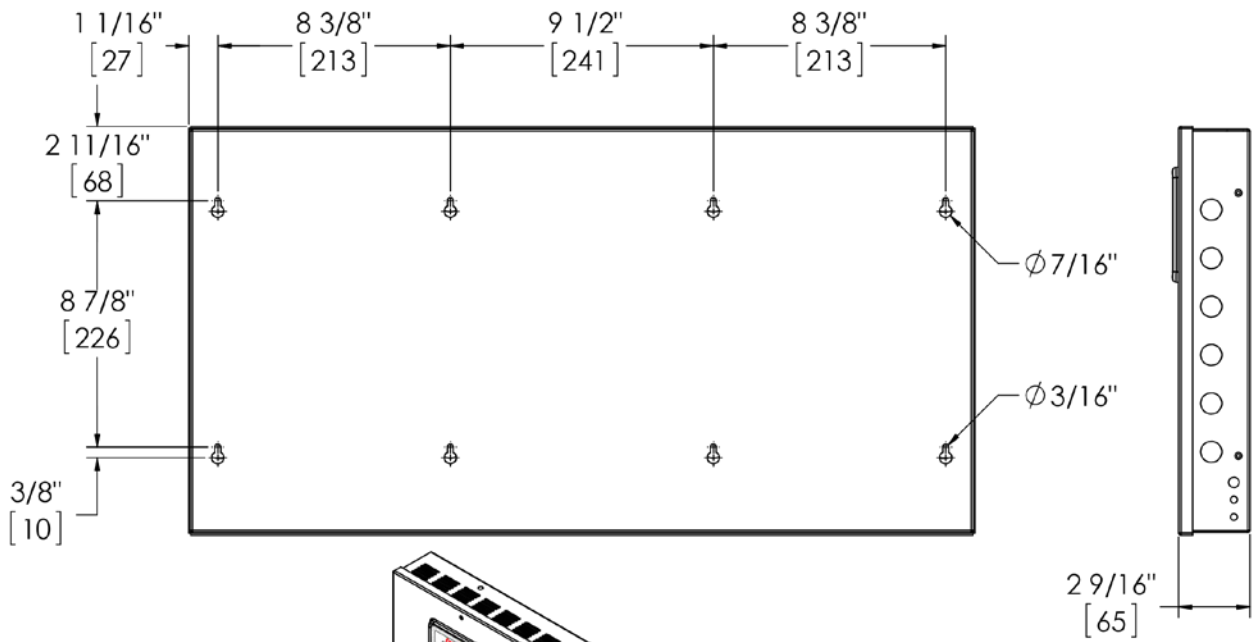
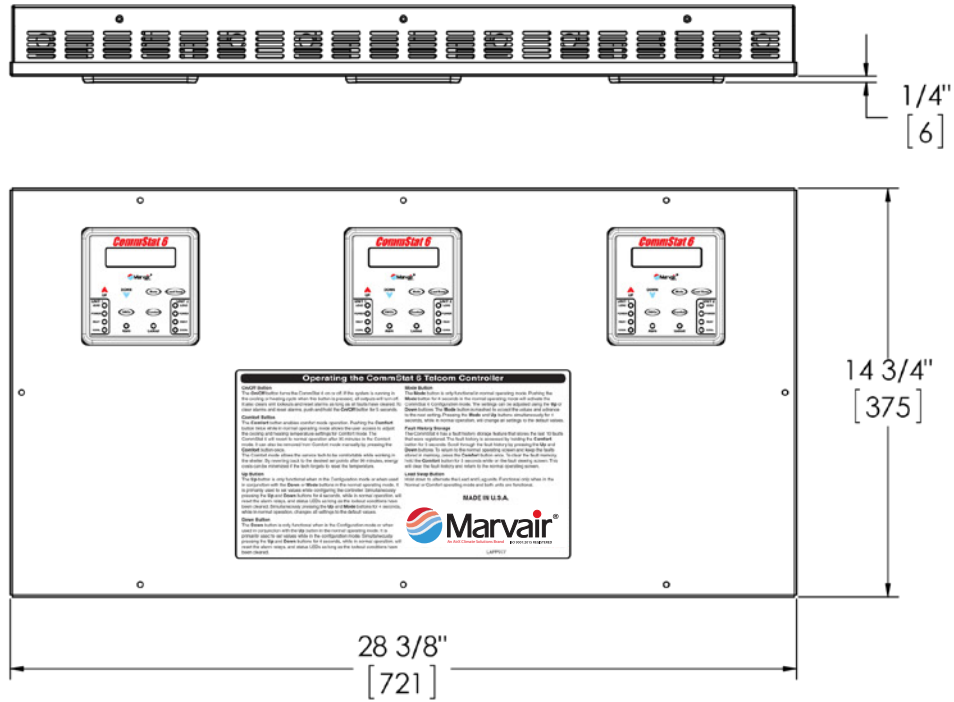

COMMSTAT 6 6/12 CONTROLLER OPERATION - SIX SINGLE COMPRESSOR UNITS

Set-Points Are Shown for Reference Only

Example Cooling Set-point 75°F (24°C) Setpoint is Adjustable

Example Cooling Differential 1°F (1°C) Setpoint is Adjustable

Indoor Temperature	Lead Unit	Lag Unit 1	Lag Unit 2	Lag Unit 3	Lag Unit 4	Lag Unit 5
75°F (24°C)	Fan Only	Off	Off	Off	Off	Off
76°F (24.5°C)	Cool	Off	Off	Off	Off	Off
77°F (25°C)	Cool	Cool	Off	Off	Off	Off
78°F (25.5°C)	Cool	Cool	Cool	Off	Off	Off
79°F (26°C)	Cool	Cool	Cool	Cool	Off	Off
80°F (26.5°C)	Cool	Cool	Cool	Cool	Cool	Off
81°F (27°C)	Cool	Cool	Cool	Cool	Cool	Cool

COMMSTAT 6 6/12 CONTROLLER OPERATION - SIX DUAL COMPRESSOR UNITS

Cooling Set-point 75°F (24°C) Setpoint is Adjustable

Cooling Differential 1°F (1°C) Setpoint is Adjustable

Indoor Temperature	Lead Unit	Lag Unit 1	Lag Unit 2	Lag Unit 3	Lag Unit 4	Lag Unit 5
75°F (24°C)	Fan Only	Off	Off	Off	Off	Off
76°F (24.5°C)	1st Stage Cool	Off	Off	Off	Off	Off
77°F (25°C)	2nd Stage Cool	Off	Off	Off	Off	Off
78°F (25.5°C)	2nd Stage Cool	1st Stage Cool	Off	Off	Off	Off
79°F (26°C)	2nd Stage Cool	2nd Stage Cool	Off	Off	Off	Off
80°F (26.5°C)	2nd Stage Cool	2nd Stage Cool	1st Stage Cool	Off	Off	Off
81°F (27°C)	2nd Stage Cool	2nd Stage Cool	2nd Stage Cool	Off	Off	Off
82°F (28°C)	2nd Stage Cool	2nd Stage Cool	2nd Stage Cool	1st Stage Cool	Off	Off
83°F (28.5°C)	2nd Stage Cool	2nd Stage Cool	2nd Stage Cool	2nd Stage Cool	Off	Off
84°F (29°C)	2nd Stage Cool	2nd Stage Cool	2nd Stage Cool	2nd Stage Cool	1st Stage Cool	Off
85°F (29.5°C)	2nd Stage Cool	2nd Stage Cool	2nd Stage Cool	2nd Stage Cool	2nd Stage Cool	Off
86°F (30°C)	2nd Stage Cool	2nd Stage Cool	2nd Stage Cool	2nd Stage Cool	2nd Stage Cool	1st Stage Cool
87°F (30.5°C)	2nd Stage Cool	2nd Stage Cool	2nd Stage Cool	2nd Stage Cool	2nd Stage Cool	2nd Stage Cool

OPERATING THE COMMSTAT 6 CONTROLLER

The CommStat 6 controller is controlled with buttons as described below.

On/Off Button

The **On/Off** button turns the CommStat 6 controller on or off. If the system is running in the cooling or heating cycle when this button is pressed, all outputs will turn off. It also clears unit lockouts and reset alarms as long as all faults have cleared. To clear alarms and reset alarms, push and hold the **On/Off** button for 5 seconds.

Comfort Button

The **Comfort** button enables comfort mode operation. Pushing the **Comfort** button twice while in normal operating mode allows the user access to adjust the cooling and heating temperature settings for Comfort mode. The CommStat 6 controller will revert to normal operation after 90 minutes in the Comfort mode. It can also be removed from Comfort mode manually by pressing the **Comfort** button once.

The Comfort mode allows the service tech to be comfortable while working in the shelter. By reverting back to the desired set points after 90 minutes, energy costs can be minimized if the tech forgets to reset the temperature.

Up Button

The **Up** button is only functional when in the Configuration mode or when used in conjunction with the **Down** or **Mode** buttons in the normal operating mode. It is primarily used to set values while configuring the controller. Simultaneously pressing the **Up** and **Down** buttons for 4 seconds, while in normal operation, will reset the alarm relays, and status LEDs with the exception of the lockout alarm which requires the power to be cycled at the AC units. Simultaneously pressing the **Up** and **Mode** buttons for 4 seconds, while in normal operation, changes all settings to the default values.

Down Button

The **Down** button is only functional when in the Configuration mode or when used in conjunction with the **Up** button in the normal operating mode. It is primarily used to set values while in the configuration mode. Simultaneously pressing the **Up** and **Down** buttons for 4 seconds, while in normal operation, will reset the alarm relays, and status LEDs with the exception of the lockout alarm which requires the power to be cycled at the AC units.

Mode Button

The **Mode** button is only functional in normal operating mode. Pushing the **Mode** button for 4 seconds in the normal operating mode will activate the CommStat 6 controller Configuration mode. The settings can be adjusted using the **Up** or **Down** buttons. The Mode button is mashed to accept the values and advance to the next setting. Pressing the **Mode** and **Up** buttons simultaneously for 4 seconds, while in normal operation, will change all settings to the default values.

Fault History Storage

The CommStat 6 controller has a fault history storage feature that stores the last 10 faults that were registered. The fault history is accessed by holding the **Comfort** button for 5 seconds. Scroll through the fault history by pressing the **Up** and **Down** buttons. To return to the normal operating screen and keep the faults stored in memory, press the **Comfort** button once. To clear the fault memory, hold the **Comfort** button for 5 seconds while on the fault viewing screen. This will clear the fault history and return to the normal operating screen.

Lead Swap Button

Hold down to alternate the Lead and Lag units. Functional only when in the Normal or Comfort operating mode and both units are functional.

ECONOMIZER OPERATIONAL MODE

The CommStat 6 controller allows two Operational Modes for air conditioners with economizers. The desired mode can be selected in Configuration screen 19 and are described below.

Economizer Mode

Economizer mode #1 allows the enthalpy controller in the lead unit to determine whether to run in mechanical or economizer cooling. On a rise in temperature exceeding the 1st stage temperature differential, the controller signals the lag unit to operate in mechanical cooling. This mode should be selected when lead and lag unit operation is needed to maintain desired building temperatures or when air conditioners are not sized for 100% redundancy.

Emergency Ventilation Mode: The CommStat 6 controller will force all connected air conditioners to economizer operation if all connected air conditioners are locked out upon a call for cooling.

COMMSTAT 6 LEAD/LAG CONTROLLER CONFIGURATION SCREENS

To enter the Configuration Mode:

1. Be sure that the CommStat 6 controller is in the normal operating mode.
2. Push the Mode button for 4 seconds.
3. Press the Up and Down buttons to change the set points.
4. Press the Mode button to accept the settings and advance to the next screen.

To change all settings to the default values, press the Mode and Up buttons simultaneously for 4 seconds while in normal operation.

To exit configuration mode, do not touch any of the buttons for 90 seconds.

Screen Number	Description	Default
1	Keypad Lockout Select OFF to disable lockout or a 3 digit number to enable lockout. Master Override: 999	OFF
2	°F or °C	°F
3	Cooling set point. 65°F thru 95°F (18°C thru 35°C) in 1° increments	77°F (25°C)
4	Heat set point. 50°F thru 80°F (10°C thru 27°C) in 1° increments	50°F (10°C)
5	First stage high temperature warning set point. 70°F thru 140°F (21°C thru 60°C) in 1° increments	85°F (29°C)
6	Second stage high temperature alarm set point. 75°F thru 145°F (24°C thru 63°C) in 1° increments.	90°F (32°C)
7	Low building temperature alarm set point. 32°F thru 65°F (0°C thru 18°C) in 1° increments	45°F (7.2°C)
8	Continuous indoor blower on all air conditioners. Select ON, AUTO or ON (Lead only).	ON (Lead Only)
9	Alarms = 0 = No alarm output. 1 = Alarm output enabled	1 (Enabled)
10	Anti-short cycle timer. 0 = no delay or 3-10 minutes in 1 minute increments..	0 (No delay)
11	ON differential for 1st stage. 1°F thru 5°F (1°C thru 3°C) in 1° increments. This setting only affects the turning on of the system.	2°F (1°C)
12	OFF differential option of all stages. 1°F thru 4°F (1°C thru 3°C) in 1° increments.	4°F (2°C)
13	Set temperature differential between stages. YES = Temperature differential. NO - Time delay.	Yes
14	When setting #13 is YES : Temperature differential between stages with a range of 1°F thru 4°F in 1° increments, or 1°C thru 2°C in 1° increments. When setting #13 is NO : Time delay between stages with a range of 10 through 600 seconds in 10 second increments.	When setting #13 is YES : 1°F (1°C) When setting #13 is NO : 60
15	Cooling blower off time delay. 0-90 seconds in 1 second increments	90 seconds
16	Operational units on generator power: 1 = Lead unit only 2 = Lead unit & one lag unit 3 = Lead unit & two lag units 4 = Lead unit & three lag units 5 = Lead unit & four lag units 6 = Lead unit & five lag units.	1
17	Smoke alarm relay reset. Automatic after 3 - 10 minutes or Manual. The smoke alarm relay can be manually reset by either cycling the 24 VAC power or clearing the fault and holding the UP & DOWN buttons for 4 seconds.	5
18	Smoke detector contacts Normally Open or Normally Closed. When configured for N.O., an open circuit between the smoke terminals will be considered a smoke fault. When configured for N.C., a closed circuit between the smoke input terminals will be considered a smoke fault.	Normally Closed
19	Economizer Configuration: No = No economizer 1 = Economizer using operational mode #1	No

Screen Number	Description	Default
20	Remote temperature Sensor(s). If YES is selected and multiple sensors are being used, the sensor with the highest temperature reading will be used to control the units when in cooling operation. In heating operation, the sensor with the lowest reading will be used to control the units. If system is neither in heating nor cooling, the temperatures will be averaged.	Yes
21	AUX 1 dry contact output. Selection are: NO = Output will be energized when there is no contact closure between the AUX1-IN terminals. NC = Output will be energized when there is contact closure between the AUX1-IN terminals OFF = Disabled. When configuration screen #19 is set to 1, this configuration screen is not accessible.	Off
22	AUX 2 dry contact output. Selection are: NO = Output will be energized when there is no contact closure between the AUX2-IN terminals. NC = Output will be energized when there is contact closure between the AUX2-IN terminals OFF = Disabled. When configuration screen #19 is set to 2, this configuration screen is not accessible.	Off
23	Excessive compressor operation. Select between 5-10 cycles per two hour period or "No" to disable. When set between 5-10 cycles and the compressor cycles more than the set point, the first stage differential will increase by 2°F (1°C).	No
24	Language Select either English, French or Spanish	English
25	Select either 1-stage air conditioner or 2-stage air conditioner. 1 = 1-stage air conditioner 2 = 2-stage air conditioner	1
26	Master/Slave setting. When connected to another CommStat 6, the user selects whether this unit is the Master (Yes), Slave 1 or Slave 2 . If two masters, two slave 1s or two slave 2s are daisy-chained, or a slave 2 is daisy-chained without a slave 1, a communication error will be displayed on the screen..	Yes (Master)
27	This setting is used to select the number of HVAC units used in the application. Selecting the correct number of HVAC units will eliminate nuisance alarms. 1 = One HVAC unit connected to the CommStat 6 controller. 2 = Two HVAC units connected to the CommStat 6 controller. One lead and one lag unit. 3 = Three HVAC units connected to the CommStat 6 controller. One lead and two lag units. 4 = Four HVAC units connected to the CommStat 6 controller. 5 = Five HVAC units connected to the CommStat 6. 6 = Six HVAC units connected to the CommStat 6 controller If a slave controller is not anticipated according to this setting but is connected, a communication error will be displayed on the screen.	6

Operating the CommStat 6 Telcom Controller

On/Off Button

The **On/Off** button turns the CommStat 6 on or off. If the system is running in the cooling or heating cycle when this button is pressed, all outputs will turn off. It also clears unit lockouts and reset alarms as long as all faults have cleared. To clear alarms and reset alarms, push and hold the **On/Off** button for 5 seconds.

Comfort Button

The **Comfort** button enables comfort mode operation. Pushing the **Comfort** button twice while in normal operating mode allows the user access to adjust the cooling and heating temperature settings for Comfort mode. The CommStat 6 will revert to normal operation after 90 minutes in the Comfort mode. It can also be removed from Comfort mode manually by pressing the **Comfort** button once.

The Comfort mode allows the service tech to be comfortable while working in the shelter. By reverting back to the desired set points after 90 minutes, energy costs can be minimized if the tech forgets to reset the temperature.

Up Button

The **Up** button is only functional when in the Configuration mode or when used in conjunction with the **Down** or **Mode** buttons in the normal operating mode. It is primarily used to set values while configuring the controller. Simultaneously pressing the **Up** and **Down** buttons for 4 seconds, while in normal operation, will reset the alarm relays, and status LEDs as long as the lockout conditions have been cleared. Simultaneously pressing the **Up** and **Mode** buttons for 4 seconds, while in normal operation, changes all settings to the default values.

Down Button

The **Down** button is only functional when in the Configuration mode or when used in conjunction with the **Up** button in the normal operating mode. It is primarily used to set values while in the configuration mode. Simultaneously pressing the **Up** and **Down** buttons for 4 seconds, while in normal operation, will reset the alarm relays, and status LEDs as long as the lockout conditions have been cleared.

Mode Button

The **Mode** button is only functional in normal operating mode. Pushing the **Mode** button for 4 seconds in the normal operating mode will activate the CommStat 6 Configuration mode. The settings can be adjusted using the **Up** or **Down** buttons. The **Mode** button is mashed to accept the values and advance to the next setting. Pressing the **Mode** and **Up** buttons simultaneously for 4 seconds, while in normal operation, will change all settings to the default values.

Fault History Storage

The CommStat 6 has a fault history storage feature that stores the last 10 faults that were registered. The fault history is accessed by holding the **Comfort** button for 5 seconds. Scroll through the fault history by pressing the **Up** and **Down** buttons. To return to the normal operating screen and keep the faults stored in memory, press the **Comfort** button once. To clear the fault memory, hold the **Comfort** button for 5 seconds while on the fault viewing screen. This will clear the fault history and return to the normal operating screen.

Lead Swap Button

Hold down to alternate the Lead and Lag units. Functional only when in the Normal or Comfort operating mode and both units are functional.

MADE IN U.S.A.



Marvair[®]
An **ACS** Brand

LAPP077

TESTING THE COMMSTAT 6 CONTROLLER

Check-Out of Cooling Cycle

Due the wide range of configurations, the following instructions are limited to checking the operation of the cooling and heating modes. If alarm or fault conditions are displayed, recheck all field wiring and the configuration screens.

Important: Be sure that the crankcase heater (if used) has been energized for at least 24 hours before starting the unit(s). Double-check all electrical connections before applying power. Marvair air conditioners with scroll compressors running on 3Ø power must be checked for proper rotation during the initial start-up. Please refer to the Installation & Operation manual for determining if the 3Ø compressors are rotating correctly. Incorrect rotation can damage the compressor and may not be covered by the warranty

Procedure:

1. In the Configuration screen No. 3, set the cooling set point temperature to a point higher than the ambient temperature. In the Configuration screen No. 5, set the heating set point temperature to a temperature that is lower than the ambient.
2. Set the time delay in the A/C control box to three minutes. On air conditioners with an economizer, check the changeover setting of the sensor and reset it if needed. (See Marvair air conditioner Installation & Operation manual).
3. Using configuration screen No. 3, slowly lower the thermostat's cooling set point temperature until the switch closes. The indoor fan should operate. Once the indoor fan turns on, allow approximately three minutes (5 minutes if the default of 5 minutes is selected in screen number 11) for the compressor to start. Note that the outdoor fan may not come on immediately, because it is cycled by refrigerant pressures.
Note: (Economizer equipped A/C only). To check the system operation under different ambient conditions, the air temperature and enthalpy sensors must be "tricked". When outdoor ambient conditions are higher than the control setting, a component cooler aerosol may be sprayed directly into the enthalpy sensor to simulate low enthalpy conditions, causing the economizer damper to open. Alternately, when outdoor conditions are lower than the set point, a source of heat such as a hair dryer can be directed on the air temperature sensor to simulate warmer conditions, which will bring on mechanical cooling and start the compressor.
4. To stop cooling, slowly raise the thermostat cooling set point to a temperature higher than the ambient. Follow the same procedure for additional units.

Note: Do not short out the enthalpy or dry bulb sensors as this will damage the economizer controls.

Note: The fan purge allows the indoor fan to run for approximately 90 seconds after the compressor is off. This operation provides a small improvement in system rated efficiency.

Check-Out of Heating Cycle

Procedure: (Applies only to air conditioners with resistance elements)

1. Using Configuration screen No. 4, raise the heating set point temperature to a setting which is higher than the ambient temperature. The fan and electric heat should immediately cycle on.
2. Move the system switch to the "OFF" position. All functions should stop.

Note: (Economizer equipped A/C only) The damper blade should remain closed during the heating cycle (unless the minimum position potentiometer has been set for constant ventilation A fully counterclockwise position corresponds to full closure of the damper. See the Marvair Installation & Operation manual for details.



Please consult the Marvair® website at www.marvair.com for the latest product literature. Detailed dimensional data is available upon request. A complete warranty statement can be found in each product's Installation/Operation Manual, on our website or by contacting Marvair at 229-273-3636. As part of the Marvair continuous improvement program, specifications are subject to change without notice.



P.O. Box 400 • Cordele, GA 31010
156 Seedling Drive • Cordele, GA 31015
Ph: 229-273-3636 • Fax: 229-273-5154
Email: marvair@airxcs.com • Internet: www.marvair.com

